



# A Digital Twin predictive maintenance framework of air handling units based on automatic fault detection and diagnostics



Haidar Hosamo Hosamo<sup>a,\*</sup>, Paul Ragnar Svennevig<sup>a</sup>, Kjeld Svidt<sup>c</sup>, Daguang Han<sup>b</sup>, Henrik Kofoed Nielsen<sup>a</sup>

<sup>a</sup> University of Agder, Jon Lilletuns vei 9, 4879 Grimstad, Norway

<sup>b</sup> Oslo Metropolitan University, Pilestredet 35, 0167 Oslo, Norway

<sup>c</sup> Aalborg University, Thomas Manns Vej 23, 9220 Aalborg Ø, Denmark

## ARTICLE INFO

### Article history:

Received 21 November 2021

Revised 8 February 2022

Accepted 23 February 2022

Available online 28 February 2022

### Keywords:

Digital twin

Facility management

Internet of things

Predictive maintenance

APAR

Air handling unit

## ABSTRACT

The building industry consumes the most energy globally, making it a priority in energy efficiency initiatives. Heating, ventilation, and air conditioning (HVAC) systems create the heart of buildings. Stable air handling unit (AHU) functioning is vital to ensuring high efficiency and extending the life of HVAC systems. This research proposes a Digital Twin predictive maintenance framework of AHU to overcome the limitations of facility maintenance management (FMM) systems now in use in buildings. Digital Twin technology, which is still at an initial stage in the facility management industry, uses Building Information Modeling (BIM), Internet of things (IoT) and semantic technologies to create a better maintenance strategy for building facilities. Three modules are implemented to perform a predictive maintenance framework: operating fault detection in AHU based on the APAR (Air Handling Unit Performance Assessment Rules) method, condition prediction using machine learning techniques, and maintenance planning. Furthermore, the proposed framework was tested in a real-world case study with data between August 2019 and October 2021 for an educational building in Norway to validate that the method was feasible. Inspection information and previous maintenance records are also obtained through the FM system. The results demonstrate that the continually updated data combined with APAR and machine learning algorithms can detect faults and predict the future state of Air Handling Unit (AHU) components, which may assist in maintenance scheduling. Removing the detected operating faults resulted in annual energy savings of several thousand dollars due to eliminating the identified operating faults.

© 2022 The Author(s). Published by Elsevier B.V. This is an open access article under the CC BY license (<http://creativecommons.org/licenses/by/4.0/>).

## 1. Introduction

Buildings' contribution to world energy use, both residential and commercial, has continuously grown, with estimations ranging from 20% to 40% [1,2]. The heating, ventilation, and air conditioning (HVAC) system is utilized as the heart of any structure to keep the indoor climate comfortable for people. However, HVAC accounts for about half of a building's total energy use [2,3]. As a result, there is an urgent need to reduce HVAC energy usage. It is concluded that the installation of basic and sophisticated controls measures, as well as the elimination of frequent faults in HVAC systems, may save up to 30% of energy consumption [4–6].

Much of the discussion has focused on energy savings, but the rise of automated building analytics and big data applications extended the scope to allow facility managers to implement predictive maintenance. Predictive maintenance is essential since

maintenance costs are around 65% of the annual facility management costs [7]. Increased equipment life, higher efficiency, and cheaper labor costs are all possible benefits of predictive maintenance.

Nowadays, there are two common ways to manage building maintenance systems. The Facility Manager (FM) either implements reactive maintenance, where the action is taken after the failure happens, or preventive maintenance, where a predetermined approach to replace building elements is utilized. In both cases, these trends do not keep pace with the development process that began in the last 20 years of building automation and maintenance operations in HVAC. The reason for that is that reactive maintenance cannot prevent failure, and preventive maintenance wastes time and money by replacing equipment in a good situation, so it can not predict the future condition. On the other hand, predictive maintenance uses historical data to capture the components' conditions and predict failure and degradation in the system [8]. In this work, we are using the predictive maintenance strategy to predict the faults in the AHU units.

\* Corresponding author.

E-mail address: [haidarh@uia.no](mailto:haidarh@uia.no) (H.H. Hosamo).

## Nomenclature

ANN	artificial neural network	FDD	fault detection and diagnosis
APAR	air handling unit performance assessment rules	HVAC	heating, ventilation, and air conditioning
AHU	air handling unit	IoT	internet of things
AR	augmented reality	IFC	industry foundation classes
API	application Programming Interface	PM	predictive maintenance
ANOVA	analysis of variance	RDF	resource description framework
BIM	building information modeling	ROC	receiver operating characteristic curve
BMS	building management system	SVM	support vector machine
CMMS	computerized maintenance management systems	URL	uniform resource locator
DT	digital twin	VAV	variable air volume
FMM	facility maintenance management		
FM	facility manager		

### 1.1. Computer-based systems and data integration

In multi-stakeholder construction projects, data interoperability is essential to the project's success as a whole. Building maintenance and everyday operations can only be successful if they are supported by accurate and timely information. Facilities management (FM) is a good example, where 80 percent of the time is spent seeking relevant information [9]. In FM, data is still widely transmitted through building maintenance systems like computerized maintenance management systems (CMMS) using paper reports and Excel spreadsheets. Traditional transfer methods might lead to service delays and wasteful maintenance procedures [10].

A variety of commercial FM software (e.g., EcoDomus, Onuma system and ARCHIBUS, and IBM Tririga and BIM 360 field) has been developed to keep track of everything from maintenance activities to work orders and service contracts to anything else that might be helpful to management or maintenance workers. While these software options are available to fulfill the needs of facilities management, no single application can address all of the needs of the industry [11]. Furthermore, static CMMS systems with preventative maintenance are a feature of these solutions, but they are also costly [12]. As a result, an as-built BIM with a Level of Detail (LOD) of 400 to 500 necessitates a dynamic CMMS system incorporating predictive maintenance [13].

Building Information Modelling (BIM) is intended to provide a way to allow the seamless interchange of information throughout the lifespan of a building by integrating various technologies and supporting the activities of industry stakeholders [14]. BIM may contribute to FM by serving as a source and repository of information to aid in the planning and administration building maintenance operations in both new and existing structures. Ding et al. [15] provided additional support for these findings, revealing that BIM allows for a 98 percent decrease in the amount of time required to update FM databases. In addition, data from the Internet of things (IoT), such as sensor networks, can be integrated with BIM to monitor the conditions of building equipment and the building environment, which is valuable for predictive maintenance. This integration is needed to build what is called Digital Twin to maintain the system. Fig. 1 shows the principle of a Digital Twin.

Developing techniques to incorporate BIM data into the FM system has become critical as data specifications like COBie and IFC (Industry Foundation Classes) open standards arise. COBie and IFC are open data specifications. The Sydney Opera House case study showed how current FM systems (such as Mainpac, HARD-EST, and TRIM) could provide FM data consistency and information interchange through IFC and BIM [16]. Researchers in the AEC/FM business is now using ontology methodologies to overcome the challenge of information interoperability [17,18]. However, there

is a lack of research on using ontology techniques to integrate BIM and FM data.

To address the issues of data exchange and interoperability, this paper used brick ontology based on COBie data, to help retrieve information from an IFC model, transfer data into COBie data standard, and finally deliver BIM data into FM systems.

Based on that, three elements are needed to deploy a practical predictive maintenance program.

- Big data collection from sensors such as temperatures, pressure, and air volume, are essential to learning how the equipment works.
- A platform that can implement automatic fault detection and diagnostics (AFDD) algorithms and conclude how to improve the maintenance system and predict the faults.
- Building information modeling to avoid traditional methods (2D models) in transfer data and visualize the results in a 3D model.

In this paper, those three elements have been used to build our predictive maintenance framework. In the next paragraphs, the above mentioned elements will be explained in details.

### 1.2. Fault detection and diagnosis

The International Energy Agency began a project in 1977 to recognize the importance of energy usage in buildings by establishing an Implementing Agreement on Energy in Buildings and Communities (EBC-formerly known as ECBCS). All work is done via a set of 'Annexes,' so-named because they are annexes to the EBC Implementing Agreement [19]. The Annexes provide significant results about typical HVAC systems and fault detection and diagnosis (FDD) techniques [20–22]. The Annexes confirm that one of the critical reasons for failures in HVAC is that buildings design without any information about future use, such as space occupancy. This lack of knowledge will make it very difficult to design the correct system accordingly.

Even if some failures can be easily detected through the alarm system of Building Management System (BMS), however, in systems like Air Handling Unit (AHU) which is considered as a complex system, many faults can not be detected by BMS, for example (heating and cooling at the same time and heating recovery issues) [23].

Artificial intelligence is one of the methods to solve the complicated fault detection process [24–26]. In literature, we can generally find two approaches, data-driven methods, and methods based on a priori knowledge from experts [20,27]. The authors in [20,27] confirmed that developing a general algorithm that can work on many units as possible is more critical than improving

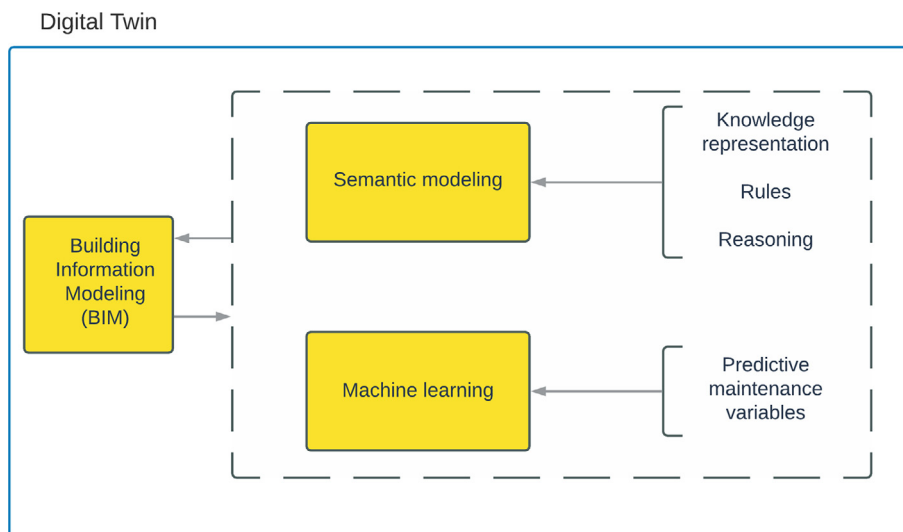

Fig. 1. The Digital Twin model.

the algorithm’s accuracy. That is because it is not economical to develop an algorithm that works to only one Air handling unit, for example. Hence, there is a need for a system that can cover various AHU schemes, dimensions and purposes, and different configurations. This algorithm also must cover the different communication protocols like BACnet that comes from different hardware in the building, which belongs to different provider companies. A solution for that may be by using BrickSchema. The BrickSchema introduces a semantic structure for the description of the physical, logical and virtual assets [28].

Another big issue within the fault detection process is to evaluate the severity of those faults. In other words, how these faults affect lifespan degradation, occupants’ comfort, and wasted energy [29].

### 1.3. Literature review

#### 1.3.1. Digital Twin for predictive maintenance

Digital Twin technology relies on several areas like the Internet of things (IoT), Artificial Intelligence, Cloud computing, and BIM [30–32]. These technologies have empowered the digitalization of the different assets to integrate a virtual object with a physical one through the entire life cycle [33].

The literature on Digital Twin has a variety of definitions. For instance [34–36]; however, Grieves defined the idea of Digital Twin for the first time in 2012. A few years later, Grieves clarified that he was referring to a set of data that thoroughly characterizes an asset, from its most basic geometry to its most specific function [37].

Digital Twin technology is utilized in preventive maintenance methods, where it is used to forecast the status of an asset in order to minimize the number of operations and allowing for longer time intervals between them [38,39]. Predictive maintenance is another use for the Digital Twin. This is directly connected to the Digital Twin’s capacity to monitor the whole system’s operation. The Digital Twin, being a virtual image of the entire system, has access to the system’s present operational data. This allows for real-time monitoring of performance and operation assurance. The Digital Twin can alert to maintenance and repairs. As a result, problems may be identified in advance and, preferably, corrected before they become severe. Maintenance procedures can be scheduled, and downtimes avoided as an outcome of using predictive maintenance.

As a result, both technological and human resources may be better used.

Systems must be appropriately designed in the early phases of development to realize the maximum potential, considering both functional needs and control techniques using digital interfaces [40]. However, complete descriptions for HVAC systems that address these ideas do not yet exist. A combination of semantic description and Digital Twin approach (including BIM, IoT, FMM, and machine learning) for HVAC Systems has not been found in the literature. Hence, this paper applies a novel framework for Digital Twin Design to HVAC systems, initially using a detailed Air Handling Unit (AHU) model.

#### 1.3.2. BIM-based predictive maintenance

Several researchers have studied how BIM models can be used for visualization and maintaining building facilities. However, these studies are limited because no automatic condition monitoring was provided [41,42]. Chen et al. [43] proposed a framework to integrate the BIM model with FM systems for automatic facility maintenance planning. However, this framework can not be used for predictive maintenance. Other researchers tried to use other technologies with BIM for facility maintenance. For example, [44,45] used Augmented Reality (AR) technology for roads maintenance and condition of components.

In addition, the application of BIM to predictive maintenance has been investigated by several researchers [46,47]. However, no case study was presented to support the suggested framework’s viability. Wang et al. [48] investigated a cloud-based paradigm for predictive maintenance of an electric motor but did not provide a prediction algorithm for condition prediction. Schmidt and Wang [49] considered cloud technology for the predictive maintenance process. Other researchers also mentioned the challenges of using big data for predictive maintenance due to the need for up-to-date and correct component data [50,51]. Deep learning and predictive algorithms for predictive maintenance have also been investigated, but without any integration with BIM applications [52,53].

Most of the above studies looked at BIM as visualization and extracting data tool; however, facility condition evaluations and maintenance plans are not included. In other words, the studies mentioned above did not provide facility managers with accurate and practical techniques for predicting future conditions, and no practical case studies were presented in these studies.

1.3.3. Machine learning (ML) for predictive maintenance

Artificial neural networks (ANN), support vector machines (SVM), Markov chains and decision trees are machine learning methods that may be used to forecast the state of building components. ANNs, unlike standard statistical approaches, can anticipate nonlinear time-series trends and maintain nonlinear failure patterns [54,55]. ANNs have been used to predict the corrosion of pipelines and estimate the service life of a facade coating; however, statistical data cannot be used for such studies [56,57]. Wind turbine problem detection was made possible thanks to the development of test equipment by [58]. The authors gathered vibration data in both a healthy and a degraded state. Healthy and faulty conditions were characteristics by using ANN. The paper’s findings show that the categorization accuracy is 92.6 percent.

SVM is another commonly used statistical learning theory-based classification algorithm. ANNs and SVMs both rely on particular examples in the training and testing samples, with the SVM approach being more sensitive to parameter values. Carvalho et al. [59] provide a systematic literature review of machine learning methods applied to predictive maintenance.

The Markov chain model was also utilized to forecast the bridge’s service life [60]. On the other hand, the Markov chain is not suitable for complex systems such as HVAC systems because it implies that the future state is only determined by the present situation, not by the previous condition, and the model uses discrete parameters.

A Bayesian network is a valuable tool in artificial intelligence. It can depict and diagnose complicated systems with inadequate or contradictory data. The Bayesian network has been effectively employed in information discovery and probabilistic inference since Pearl presented it in the early 1980s [61,62]. MUNIN [63], and Sleep Consultant [64] are commercial computer-aided diagnostic decision support systems that use Bayesian Belief Network (BBN). Industrial applications of BBN-based diagnostic systems include nuclear power systems [65], sensor failure detection [66],

and others. Mokhtari et al. [67] used Bayesian Inference to calibrate a wind speed sensor in a thermal power plant. Raillon et al. [68] used a unique Bayesian experimental calibration approach to calibrate dynamic thermal models. Najafi et al. [69] and Wall et al. [70] Both efforts used machine learning to train Bayesian networks with fault-free data. Other applications included chiller FDD [71] and VAV terminal FDD [72]. Liu et al. [73] suggested a unique Bayesian fault detection algorithm. The approach employed a modest quantity of measurement data to estimate the statistical properties of fault levels. Zhao et al. [24] suggested a diagnostic Bayesian network-based technique to diagnose 28 AHU defects. However, there is no commonly acknowledged Bayesian network construction approach, and no clear winner has emerged to this point [74,75]. This weakness has two distinct drawbacks: designing a Bayesian Network takes much time, as a result, Bayesian Networks can only utilize causal influences identified by their programmer. On the other hand, neural networks may learn any pattern and are not constrained by the programmer.

Random forest is another approach that has been proposed by Leo [76]. As the name implies, a Random forest assembles many randomized decision trees into a “forest” (ensemble) and averages their predictions. In Predictive maintenance applications, Random forest is the most often used machine learning technique. The primary justifications are as follows: decision trees allow a large number of observations to be included in the forecast, as mentioned in [77]; and Random forest can minimize variance and enhance generality in particular circumstances, as detailed in [78]. The Random forest technique, on the other hand, has certain disadvantages. The Random forest technique, for example, is complicated and takes longer to compute than other ML methods.

As a result of the datasets obtained in this study, and the methodologies we examined, the ANN, SVM, and decision trees algorithms were chosen as machine learning models to predict future conditions for this study.

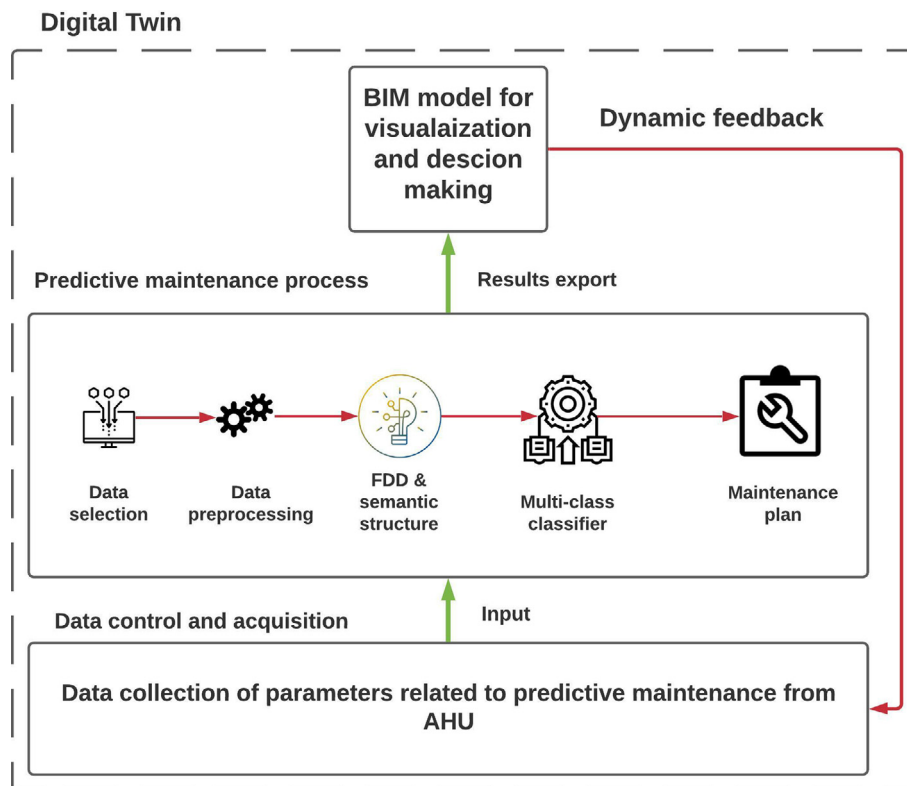

Fig. 2. The Proposed Digital Twin predictive maintenance framework based on expert rules, Machine Learning, BIM and IoT for AHU.

### 1.3.4. AFDD of AHU

To plan maintenance before failure, preventative maintenance programs use BMS data and a CMMS. However, AFDD is used in predictive maintenance programs to eliminate the fundamental cause of failure before it occurs, help facility management staff prioritize maintenance activities, and identify defects that might otherwise go undetected by traditional methods.

Several researches have been conducted recently of AFDD of AHU. Some focused on simulation specific parts of AHU [79,80], while the others used expert rules rather than complicated calculations [81]. Regarding expert rules manner, AHU performance assessment rules (APAR) were defined by House et al. [81] as a set of 28 if-then rules assessed based on an AHU's operational regime. The APAR technique drew much attention and was later expanded upon by others [82,83]. Other researchers tried to extend APAR rules and develop new tools for faults detection; however, their tools were for a specific type of HVAC and with simulated data [84,85]. However, according to Trojanová et al. [83], it is challenging to develop a general model-based for HVAC.

In recent years, researchers focused on machine learning and data mining for fault detection [86]. However, machine learning alone can not be adopted for two critical reasons [87]:

- The need for large datasets to increase the number of faults that can be detected.
- It is not possible to build a universal system based on machine learning alone.

### 1.4. Novelty of our research

Out from the above-reviewed research work, the gaps in the literature are as follows;

- Lack of a Digital Twin model for predictive maintenance of HVAC system and specifically Air Handling Unit.
- Lack of practical degradation system and workflow process.
- Lack of universally applicable AFDD system.

Based on the research gaps mentioned above, this study:

- Describes a Digital Twin framework for the predictive maintenance implementation process.
- Uses of practical machine learning algorithm for predictive maintenance based on real-time data.
- Uses of universal AFDD tool that can efficiently run on a varied set of data from IoT sensors in AHUs.
- Develops an integrated condition monitoring framework based on BIM technology for decision-making in FMM.

## 2. The proposed framework

The proposed framework utilizes Digital Twin technology for fault detection and diagnostics and predicts the condition of the building components so that the facility management staff can make better decision at the right time, as shown in Fig. 2. This framework is based on our developed method by integrating the new technologies, particularly BIM, IoT, semantic metadata and expert rules, and ML. The framework includes three main steps, Data acquisition, predictive maintenance process, and BIM model for information visualization and monitoring. Spatial information can be obtained from the BIM model. The BIM model was integrated with predictive maintenance results to support decision-making by developing a plug-in extension for Autodesk Revit using C sharp so that the FM team can easily understand the data. The three main levels of this framework will be explained in detail in the following sections.

### 2.1. Data control and acquisition

Based on the literature review (for example, [88,89]), component parameters related to predictive maintenance are identified. Hence, the necessary knowledge to complete the working framework is classified into three groups:

- (1) BIM model to give information of building components, such as dimensions, materials, and installation year, illustrates the deteriorating tendency over time.
- (2) Sensor data from the IoT sensor network to monitor facility conditions, the trend of sensor data, and the usage behavior of the components. For example, temperature, pressure, and flow rate are collected from sensors in AHU.
- (3) Usage age, maintenance record, and irregular intervals for inspection data for the FM system, including how long it has been since the last inspection.

#### 2.1.1. Data in BIM model

The BIM model will be used in two directions in this study, i.e., as input for predictive maintenance and to visualize the results. FM and predictive maintenance benefit from a BIM model's geometric and semantic features (non-geometric). So, as-built BIM models should have certain graphical and non-graphical information for predictive maintenance, such as component size, materials, and installation year.

For facility management, COBie (Construction Operations Building Information Exchange) and Industrial Foundation Classes (IFC) are information exchange specifications for the lifetime capture and transfer of information [90,91]. In IFC files, information about building components and their interrelationships is stored. Classes of objects, relations, and resources make up the IFC file structure. In terms of geometry, IFC can express information like length and height. Various semantic information may be stored in IFC, such as a construction component cost and timeline [92]. In addition, COBie may instantly provide information on the operation, maintenance, and management of projects to facility managers [93]. Hence, IFC may provide geometric and semantic information in BIM models; however, COBie should supply more information such as spatial information, asset details, documentation, and

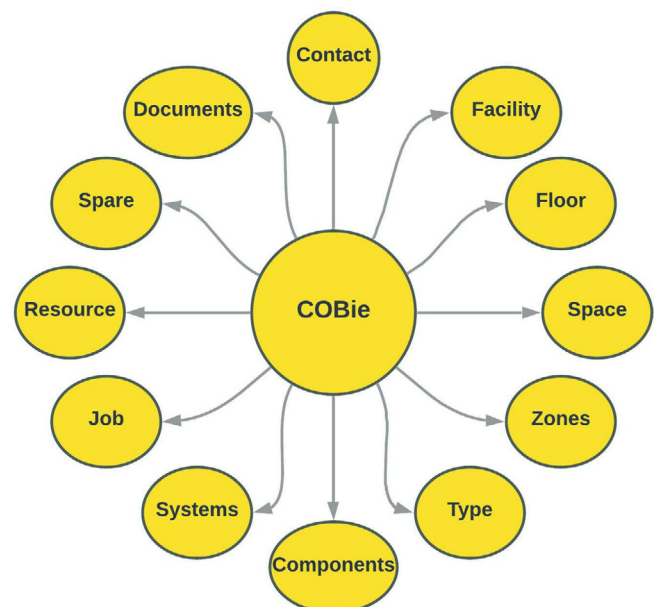















Fig. 3. Standard COBie components.

Foler	Type	Dimensioner	Folerelement (NTC 12k@25°C)	Materiale	Anvendelse
	ETF-122	Ø6,5x30mm, 2,5 m kabel	NTC 12k +25°C = 12kΩ Område -40°C-+120°C	Polyolefin Keramik Rustfri AISI 316	Universalfoler Eks. gulvfoler
	ETF-144/99A	Ø6,5x30mm, 2,5 m kabel	NTC 12k +25°C = 12kΩ Område -20°C-+70°C	ABS plastic PVC insulated	Universalfoler Eks. gulvfoler
	ETF-422	Ø6,5mm, L100mm 1/4" pipe, 2,5 m kabel Max pressure 6 atm.	NTC 12k +25°C = 12kΩ Område -40°C-+120°C	Galv. messing	Ikke-aggressive væsker og medier
	ETF-522	Ø6,5mm, L50mm 2,5 m kabel Max pressure 0.5 atm.	NTC 12k +25°C = 12kΩ Område -40°C-+120°C	Galv. messing	Universalfoler Maskindele
	ETF-622	8 x 12mm Hole Ø3.5mm 2,5 m kabel	NTC 12k +25°C = 12kΩ Område -40°C-+120°C	Kobber	Maskindele Overflader
	ETF-744/99	86 x 45 x 35mm	NTC 12k +25°C = 12kΩ Område -20°C-+70°C	ABS plastic Melamin	Fugtige områder Udendørs
	ETF-822	Ø6,5mm, L200mm 1/4" pipe, 2,5 m kabel Max pressure 6 atm.	NTC 12k +25°C = 12kΩ Område -40°C-+120°C	Galv. messing	Ikke aggressive væsker og medier
	ETF-944/99H	80 x 80 x 16 mm IP20	NTC 12k +25°C = 12kΩ Område -20°C-+70°C	Bayblend noryl	Rumfoler Tørre rum Indendørs
	ETF-1133/44/55	Ø6,5x200mm Flange 2,5 m kabel	NTC 12k +25°C = 12kΩ Område -20°C-+70°C	Galv. messing	Ikke-aggressive væsker og luftarter
	ETF-1633/44/55	60 x 30 x 30mm Max pipe diameter 50mm Inkl. fastgørelse IP54	NTC 12k +25°C = 12kΩ Område -50°C-+70°C	Polycarbonat Rustfri AISI 316	Overflader på rør
	ETF-1733/44/55	55 x 52 x 27mm IP54	NTC 12k +25°C = 12kΩ Område -40°C-+70°C	Polycarbonat	Fugtige områder Udendørs Ikke-aggressive
	ETF-1899A	Ø12,0 x 40mm, 2,5 m kabel Flad på folerside Ekskl. fastgørelse	NTC 12k +25°C = 12kΩ Område -20°C-+70°C	Polycarbonat	Universalfoler til overflader
	ETF-2	Ø8mm L100mm 1/4" RG		Galv. messing	Folerlomme ikke-aggressive

NTC 12k modstandstabel						
-20°C = 112246Ω	11°C = 22300Ω	16°C = 17750Ω	21°C = 14238Ω	26°C = 11506Ω	35°C = 7978Ω	60°C = 3201Ω
-10°C = 63929Ω	12°C = 21292Ω	17°C = 16974Ω	22°C = 13636Ω	27°C = 11035Ω	40°C = 6569Ω	70°C = 2306Ω
0°C = 37942Ω	13°C = 20335Ω	18°C = 16237Ω	23°C = 13064Ω	28°C = 10587Ω	45°C = 5442Ω	80°C = 1692Ω
5°C = 29645Ω	14°C = 19428Ω	19°C = 15537Ω	24°C = 12519Ω	29°C = 10159Ω	50°C = 4535Ω	90°C = 1263Ω
10°C = 23364Ω	15°C = 18567Ω	20°C = 14871Ω	25°C = 12000Ω	30°C = 9752Ω	55°C = 3800Ω	100°C = 958Ω

CE MÆRKNING

ETF-serien overholder kravene i følgende direktiv:

MASKINDIREKTIVET  
89/392/EEC

Fig. 4. AHU sensors datasheet.

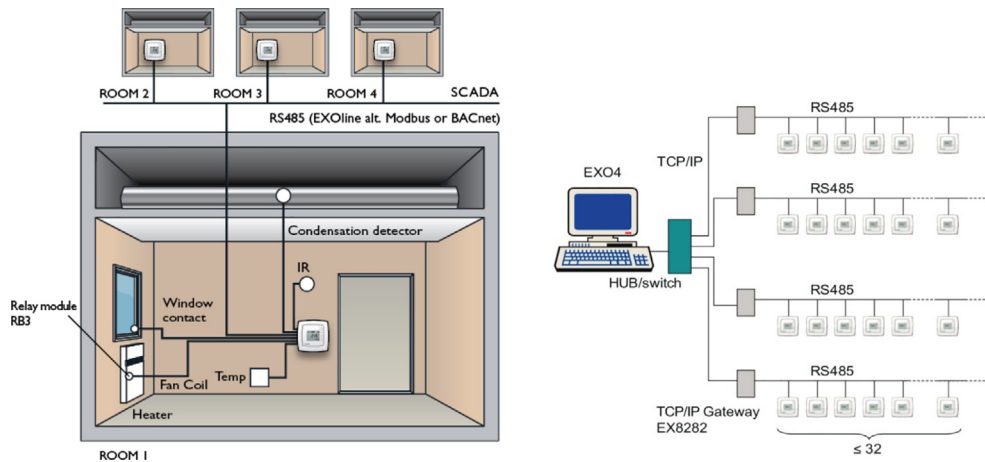

Fig. 5. An example of the application system [94].

RC-C3H, RC-CTH



RC-C3, RC-CT



RC-C30, RC-CTO



RC-CDTO, RC-C3DOC



RC-CF



RC-CFO



RC-CDFO, RC-C3DFOC



Fig. 6. System controllers [94].

graphical information, among other features. Therefore, a COBie extension for Revit was utilized in this article to extract the necessary information from the BIM models for predictive maintenance and transmit it to the FM system. Fig. 3 shows COBie components.

### 2.1.2. Sensor data collection and maintenance record

A Restful API (Application Programming Interface) has been built as an additional analytical layer over a conventional BMS system. This allows using a specific URL (Uniform Resource Locator) to extract data from each device in the building, which will, in turn, allows to reach of a large number of diagnosed devices. The restful API also allows reaching the maintenance record system and previous alarms and faults. Fig. 7 is a schematic representation of the principle of the whole system. During the operating phase, Internet of Things sensors network is constructed to collect sensors data from the building's facilities and the surrounding environment. These sensors include NTC-12 K-sensors for temperatures, PTH-3202-DR for peressure, TTH-6040-0 for outdoor temperature and the IVL10 temperature-sensitive airflow transmitters. A data sheet of sensors is shown in Fig. 4. In addition, Regio controllers have been used to handle everything from temperature, lighting, humidity, CO2 levels, and even blinds. Additionally, Regio provides online and Internet services. A PC linked to the workplace network may be used to regulate the temperature and other operations of a room. Fig. 5 and Fig. 6 show the application system and the controllers, respectively.

Also, Plugin is built in the BIM model with Microsoft Visual Studio Community 2019, allowing for the visualization and storage of real-time sensor data directly in the BIM model. The Application base class implements an external application interface to create the tab, the ribbon, and the buttons of the plugin. This fully-featured plugin is excellent for facility managers since it allows them to access real-time sensor data and save it in the relevant condition database (MSSQL DB) while keeping BIM up to date. The "Sensor Data" button allows FM managers to view the current sensor data as well as the historical sensor data's maximum and minimum values. The condition database also allows FM managers to verify the sensor's average value and historical value. By pressing the "Store" button, the sensor data is saved in real-time, as shown in Fig. 8. In the last step, the sensor data are employed in the FMM process for condition monitoring and prediction.

The BACnet (Building Automation and Control Networks) protocol is extensively used as a data communication protocol among various equipment, devices, and sensors to get real-time operational data from the IoT sensor network [95]. The Regio display tool can modify the protocol and then return the protocol to Modbus.

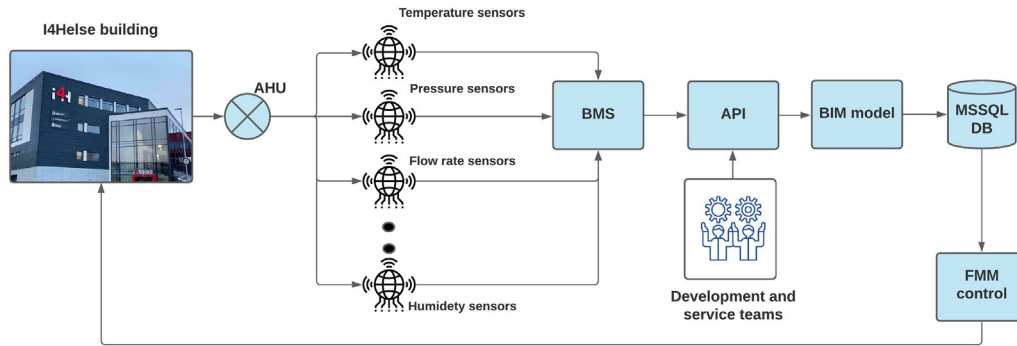

Fig. 7. IoT data collection system including API developed by service and developed teams.

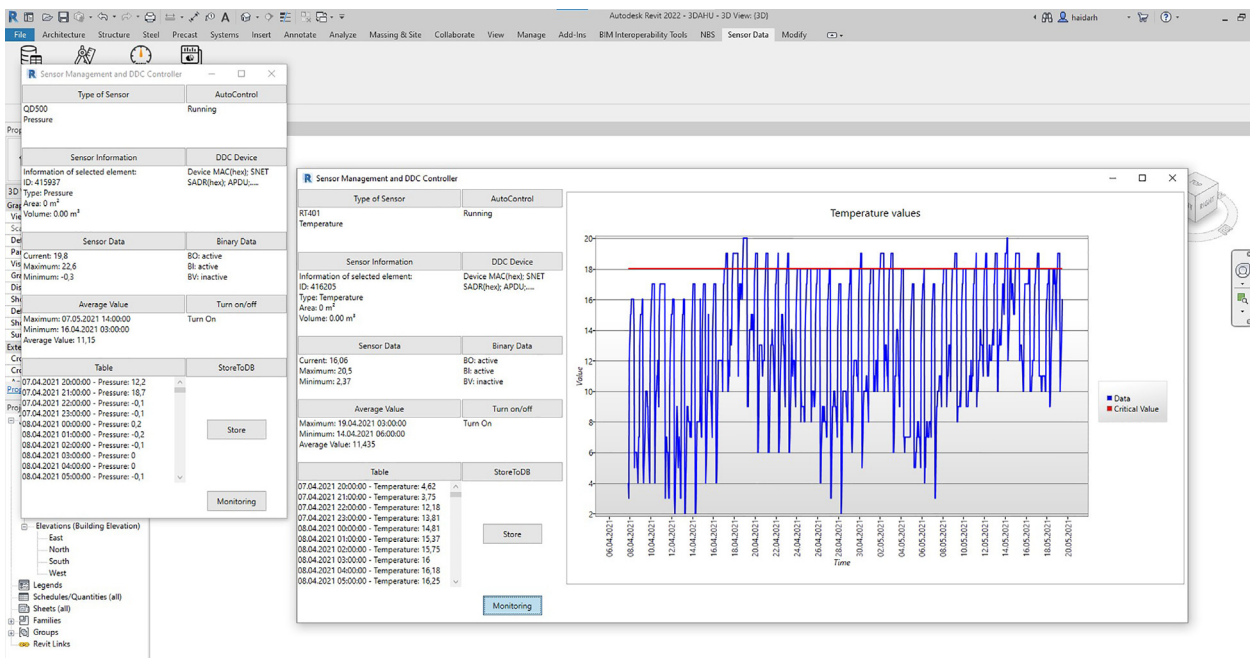

Fig. 8. The plugin for sensor management.

Table 1  
Analogue inputs.

Object name	Object-ID	Description
RC_Actual_R.RegioRoomTemp	Analog input, 0	Room temperature
RC_Actual_R.RegioAlChangeOver	Analog input, 1	Change over temperature
RC_Actual_R.RegioAnaln1	Analog input, 2	Value of analogue input 1
RC_Actual_R.RegioUAnaln1	Analog input, 3	Value of universal analogue input 1
RC_Actual_R.RegioRoomCO2	Analog input, 4	CO2 input value

Setpoints, control parameters, trend logs, and alarms are all examples of operational data. Setpoint data and sensor-derived condition data will be the focus of this study to provide information on the present state of the equipment and facilities. Temperature, pressure, flow rate, and ON/OFF state are all supported by BACnet in an IoT sensor network. Modeling a wide range of sensor-derived operational information is accomplished by using eight different types of objects and their attributes: (1) Analogue inputs, (2) Analogue values, (3) Binary inputs, (4) Binary values, (5) Loop, (6) Multistate inputs, (7) Multistate values and (8) Device. Table 1 and Table 2 illustrate analog inputs, and a binary signal, respectively.

## 2.2. Data integration

### 2.2.1. Data integration between BIM and FM

For facility managers, COBie serves as an information exchange specification for data lifetime capture and distribution [90]. Despite this, compatibility between IFC and COBie is still a problem because of the FM system's data structure, which differs from BIM models' data syntax. BIM data may be integrated with FM data using COBie. COBie spreadsheets are used to import data from BIM models that have been pre-selected according to user-defined parameters. The names of characteristics in COBie spread-



**Table 2**  
Binary inputs.

Object name	Object-ID	Description
RC_Actual_L.RegioDIOpenWindow	Binary input, 0	Indicate open window
RC_Actual_L.RegioDICondenseAlarm	Binary input, 1	Indicate condense alarm
RC_Actual_L.RegioDIPresences	Binary input, 2	Indicate presence from digital input
RC_Actual_L.RegioDIChangeOver	Binary input, 3	Indicate change over from digital input
RC_Actual_L.RegioRoomTempHighTempAlarm	Binary input, 4	Room high temperature alarm

**Table 3**  
The information for data integration between IFC, COBie and FM.

System	Class
IFC	Equipment name
	Size(length – width -height)
	Material
	Elevation
	Equipment number
	Location (area/floor/room)
	Equipment type
	Equipment function
	Equipment units
	COBie
Purchase date	
Responsible person	
Equipment specification	
Equipment professional information	
Warranty	
FM	Manufacture information
	Appearance description
	Special detail of model
	Assembly process
	Operation manual
	2D drawing
	Equipment performance table
	Damages
	History maintenance records
	Maintenance schedule
Replacement	

sheets are frequently distinct from those found in FM system data, which can be problematic. Because of this, the COBie data must be mapped into FM systems using the FM relational data structure.

This integration effort is divided into two components: (1) data mapping between the IFC schema and a portion of the COBie data schema, and (2) the whole COBie data schema. COBie data may be collected from BIM models following data mapping.

The first step in mapping IFC data into COBie and FM systems is determining what information is necessary for FM operations. An initial study was conducted to assess the support of asset register information needs by IFC/COBie data entities based on the definition of asset information requirement ISO 19650-1:2018 [96], standards of PAS 1192-3:2014 [97], and buildingSMART 2021 [98].

Table 3 presents the BIM-FM model’s information checklist in light of this. Table 3 shows that information for FM is backed by BIM models, COBie data, and an FM system. Data from BIM models may be sent in IFC format using an ontology-based strategy for FM data encoding, outlined in this paper. In order to create an ontology file that can be read using GraphDB [99], Python was utilized to finish an entire automated mapping procedure.

In Graph DB, entities and entity relations may be readily generated, as demonstrated in Fig. 9. SPARQL, an RDF query language that uses Internationalized Resource Identifiers (IRI) to identify the location of the ontology, may be used to query the file.

Autodesk Revit was chosen in this paper as the BIM software, with Laugstol’s ENS-portal [100] chosen as the FM system. Data from BIM models are extracted, and the COBie extension plug-in for Revit is used to convert data from BIM models to COBie spreadsheets. Part of the information for facility information requirements for maintenance operations is exported from BIM models based on IFC.

The attributes of COBie data and attributes of data in the FM database should be mapped one by one after getting COBie data from BIM models. Using the COBie connector code we wrote in Python, the attributes of the components in the COBie spreadsheet are translated to the equivalent attributes in the FM system. Data from COBie spreadsheets may be imported into the FM system column by column using the connector code.

### 2.2.2. Sensor data integration into BIM model

A Revit plug-in is needed to receive, store, and display real-time sensor data because Revit and other BIM design applications do not have these capabilities. The data from the sensors is shown in a BIM model thanks to this Revit C#.NET API add-in plug-in. The system.net object is used to transfer sensor data into the Revit model. The System.net object uses the URL from the sensor data API to bring the data into the BIM model [101].

The IFC entity does not include a sensor type. Sensors may be represented using IfcSensor and IfcSensorType. IfcSensor type transfers sensor data into the BIM model when we establish the sensor family in Revit for a neutral data format.

On the other hand, the BIM model can only record transitory data from sensors. Thus, every sensor data will end up in the condition DB at some point (Fig. 7). The sensor data is then combined into a BIM model and rendered for visual display using Revit’s new plug-ins. Finally, the sensor data may be conveniently accessible in the BIM model for condition evaluation.

### 2.3. Predictive maintenance process

In predictive maintenance, faults in the building components are found and predicted early. The FM system gathers the FM data, while its specific sensors (Fig. 7) measure the condition monitoring data.

#### 2.3.1. Data selection and pre-processing

When using machine learning approaches, feature selection is critical since it allows the techniques to filter out redundant and noisy data throughout the training process. The noisy data was observed at several condition indexes, including (1) chilled and heater water temperature sensor, (2) dampers condition, (3) heating and cooling valves conditions, (4) zone temperature, (5) fan conditions, and so on.

The dataset is entered into the data preparation process, which includes two steps: data cleaning and data normalization. The

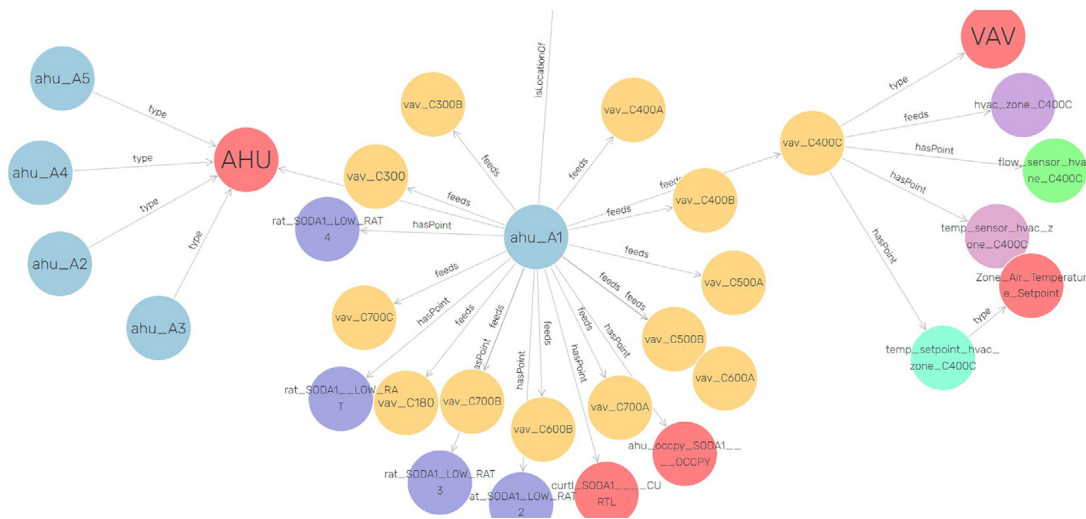

Fig. 9. Part of the ontology graph in GraphDB.

noisy and low variance data are deleted during the data cleaning process, and data normalization is utilized to decrease the scale disparity between each data set. The data is transformed into a range between 0 and 1 using the StandardScaler technique [102]. Feature selection is used to eliminate unwanted features from a dataset, whereas data reduction removes unneeded data. This study will integrate the Analysis of Variance (ANOVA) approach with Support Vector Machine (SVM) to increase classification performance [103,104]. ANOVA examines the variance of each feature in the dataset, whereas SVM improves the classifier’s performance. Several metrics are generated by the ANOVA-SVM approach, including the ANOVA-SVM score, the accuracy score from each subset test, and the distance value between each data point and the decision border. The distance value of each feature to its decision border is the generated data from the ANOVA-SVM process, and the closer each feature is to its boundary, the more critical it is. The more relevant the data is to its label, the closer it is to the decision border.

2.3.2. AHU condition assessment and fault alarming

Condition monitoring and fault alerting are two essential phases in the process of predictive maintenance. Condition monitoring gathers and interprets important component parameters to determine whether a component’s status has changed from its usual state and whether the equipment’s health has changed over time.

The expert rules in by Nehasil et al. [29] based on the APAR method by Schein et al. [105] was used to establish our condition assessment system and deploy diagnostics in a broader number of devices in our study. Schein et al. [105] provide a list of 28 different detection rules developed from only 11 data points in their study. The majority of the rules are dependent on the mode of operation of the AHU. It is necessary to test the heater differently depending on whether the AHU is heating or cooling. Once the operating mode for a given timestamp has been determined, the relevant set of rules can be triggered for that timestamp. In most cases, the regulations are not sophisticated and rely on uncomplicated calculations covering a specific physical or regulatory event.

It is also important to link data points to the diagnostic system’s inputs for the system to function correctly. This is accomplished by using a semantic description of data: metadata (tags) that have been given to data points by human specialists following the standard established by the Haystack Project [106] and Brick Schema [107] to retain the highest level of possible compatibility. Fig. 10 defines Brick Schema concepts to which a Point can be linked to: Location, Equipment and Measurements [107].

2.3.3. Metadata

Data regarding physical, spatial, and virtual assets and their interactions inside a structure are essential to building operation analytics because it offers semantic information about the assets and their relationships. We utilized a Brick schema to store the information about the AHU models we created. Brick is a data format that is open-sourced and intended to offer consistent semantic descriptions for construction assets. It was necessary to construct a single Brick model. The Brick model is expressed in the Turtle (TTL) file format using the Resource Description Framework (RDF) language and the Resource Description Framework (RDF) language. RDFS (Resource Description Framework) is a general-purpose language that may be expressed in a concise and natural text format. Fig. 11 depicts the entity classes that exist in the building, as well as their connections. There may be many instances of each entity class. When the Variable air volume (VAV) system class interacts with the AHU class, the “Feed” relationship between the two classes is established. A single “AHU” instance can feed many “VAV” instances in the same building model. The “hasPoint” relation is a term used to indicate telemetry related with equipment, for example, VAV hasPoint zone air temperature sensor.

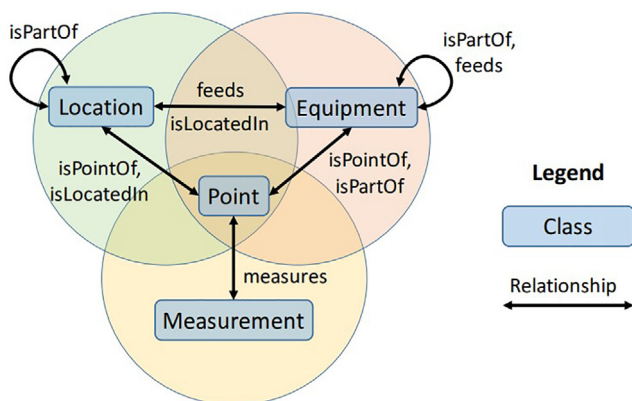

Fig. 10. Brick Schema concepts and their relationship to a data point [107].



Fig. 11. Brick schema model of AHU.

2.3.4. Multi-class classifier and maintenance plan

Many factors can cause HVAC system failures, the most common of which include insufficiently educated or untrained operators, a lack of regular maintenance, a problem with the control system, or incorrectly set requirements in the building management system (BMS). It is relatively uncommon to find faults in complicated systems (e.g., the AHU) that cannot be discovered using ordinary BMS tools (e.g., using heating or cooling to balance the non-optimal heat recovery [23]). Ideally, the severity of a failure for each fault identified might be determined based on occupants' discomfort, wasted energy, and the risk to the equipment operated. Obtaining such data is not possible from BMS. A severity index for each problem will eventually become meaningless if the relevant data is missing. Instead, this research presents a framework for predictive maintenance, which attempts to enhance maintenance decisions by identifying faults and forecasting the status of AHU components.

A combination of data from the condition monitoring sensors, the FM system's data, and BIM data will be employed in the prediction process. According to Section 1.3.3., ANN, SVM, and decision tree algorithms are used in this work to forecast the faults of AHU components. In Fig. 12, it can be seen how the algorithm for predictive maintenance works in action. Sixteen factors are fed into this forecasting algorithm from three different systems, including BIM models, FM systems, and IoT sensor networks. The following is a list of the 16 different variables: (1) AHU type, (2) location, (3) capacity, (4) material, (5) dimension, (6) installation year, (7) temperature sensors values (supply and return air to the building, zone temperature, outside temperature, supply and return temperature from the chiller, and supply and return temperature from the heater), (8) pressure sensors values, (9) flow rate sensors values, (10) usage age, (11) valves positions, (12) abnormal event times per year, (13) minor repair times per year, (14) significant repair times per year, (15) problem type, and (16) operational regime

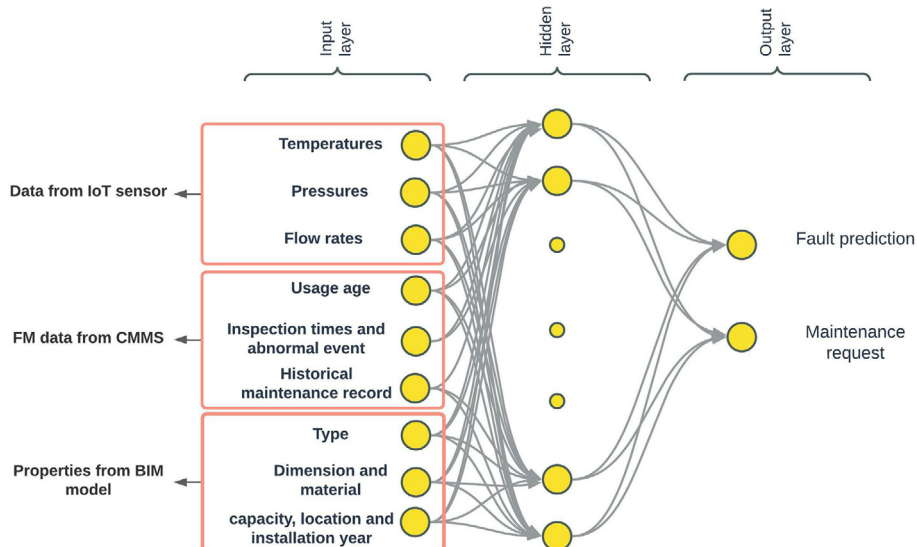

Fig. 12. The prediction algorithm process.

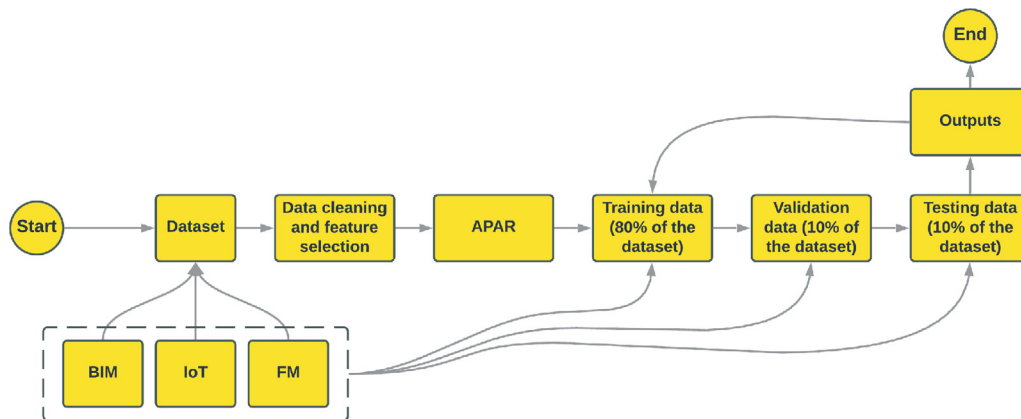

Fig. 13. The data-flow and implementation process for fault prediction.

(ventilation, heating or cooling). The output of this prediction process includes (1) the faults of AHU components based on APAR and (2) maintenance requests.

The suggested predictive maintenance system allows for dynamic model training and prediction. Prediction models are trained using real-time sensor data that is updated in real-time and maintenance records gathered over time. As seen in Fig. 13, the parameters of the prediction models are gradually updated to reflect the changing situations.

Fig. 13 depicts the prediction technique in action. There are four steps in the prediction process: (1) training, (2) cross-validation, (3) testing, and (4) prediction. The preparation steps include (1) datasets collection (Section 2.1.1 and Section 2.1.2), (2) Data selection and pre-processing (Section 2.2.1), (2) APAR (Section 2.2.2), and (3) machine learning algorithm selection. The 16 variables, the input datasets, are utilized for training and testing the prediction model, as indicated above.

The data sets for the specified variables (input datasets) are used to train the ANN, SVM, and decision trees methods, which result in prediction models. A random distribution of input datasets is used to divide them into three groups: (1) 80 percent for model training, (2) 10 percent for validation, and (3) 10 percent for testing the models. Machine learning models are taught using a training set; on the other hand, a testing set is used to test the trained models and continually correct them by modifying the weights of the machine learning algorithm linkages. It is necessary to use the remaining data set (10 percent) to validate the trained model. These models are created by adjusting the trained models based on dynamic updating data, including the acquired dynamic sensor data and the updated maintenance records, and then retraining the models. Following that, the maintenance plan must be rescheduled to coincide with the predicted condition produced by the model, as described above. Last but not least, the well-trained models are put to use to estimate the future status of various components (one and 4.5 months later).

### 3. Case study

#### 3.1. Background

A study of an educational building on the University of Agder campus (I4Helse building), Grimstad, Norway, was conducted to verify the proposed Digital Twin predictive maintenance framework. A total of 4 AHUs serves this campus building. In order to monitor the AHUs, many types of sensors have been placed, including but not limited to (1) temperature sensors, (2) pressure sensors, and (3) flow rate sensors. The signals were gathered from

the sensors and transmitted to the BIM models for further processing. In Fig. 14, the BIM model generated for the I4Helse building has been chosen to serve as an example.

#### 3.2. Tested AHU units

The tested units were equipped with a rotary heat exchanger, as well as a bypass, a heater, and a cooler. These units were in charge of conference rooms, classrooms, offices, corridors, laboratories, and other facilities. Fig. 15 illustrates a typical layout of the AHU in the buildings.

#### 3.3. Data collection

The FM manager and maintenance technicians can obtain the geometrical and non-geometrical of the AHU from the BIM model, as shown in Fig. 16. This information is used for condition inspection and condition assessment. The real-time data is gathered from the IoT sensor, including supply air pressure and temperature, exhausted air pressure and temperature, supply air temperature setpoint, damper position, chiller valve position, heater valve position, water temperature from the heater, temperature of return heating coil and flow rate of water. In order to demonstrate how long-term patterns in sensor data may be utilized to forecast future circumstances, we collected sensor data between August 2019 and August 2021 for I4Helse building. Fig. 17 shows some resample measurements in python during January and February 2020. Inspection information and previous maintenance records are also obtained through the FM system.

#### 3.4. Selected features for expert rules

There are 74 features in the original dataset gathered from buildings, from which we have selected 18 of the most critical features for the expert rules implementation done in this part. The top 18 vital features (Table 4) are selected using a combination of Analysis of Variance (ANOVA) for feature selection, which reduces the high data dimensionality of the feature space, and SVM algorithms for classification, which reduces the computational complexity and increases the effectiveness of the classification [108].

#### 3.5. Faults detection

As previously stated, several sensors are used to monitor the performance of each AHU. As seen in Fig. 16, the sensor data and trends may be represented graphically in the BIM model. Based on the sensor data, the facility manager may determine the opera-

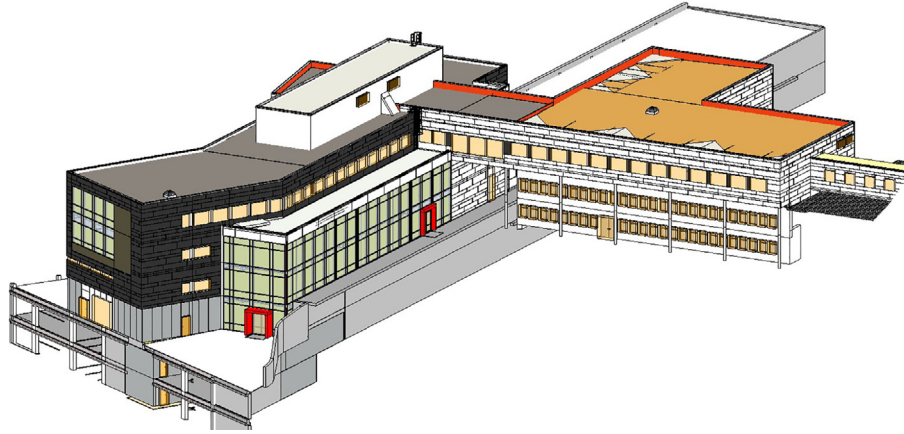

Fig. 14. I4HELSE BIM model.

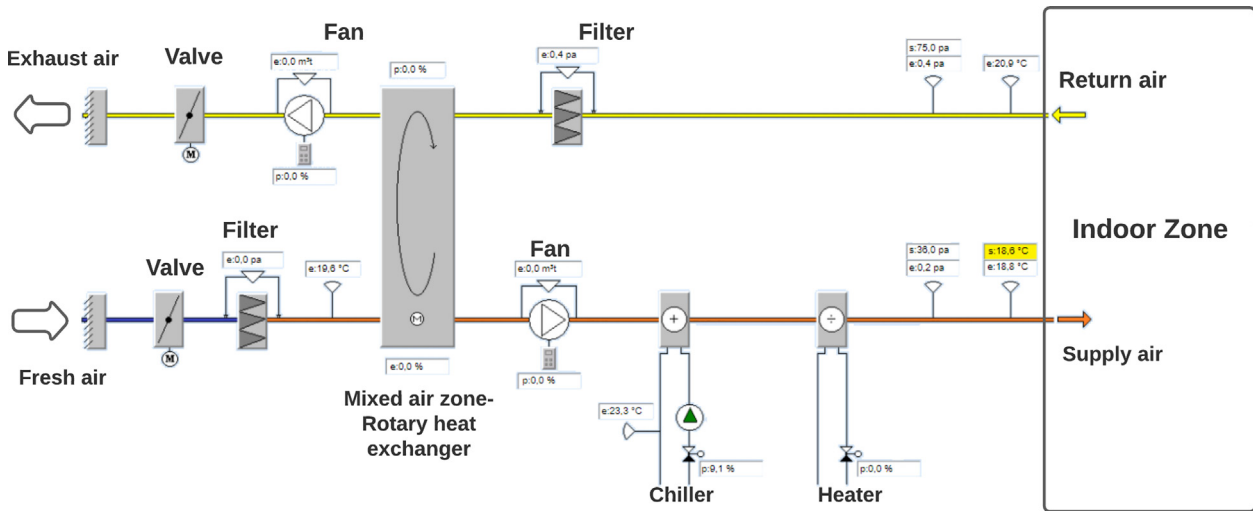

Fig. 15. Schematic illustration of an AHU from I4Helse.

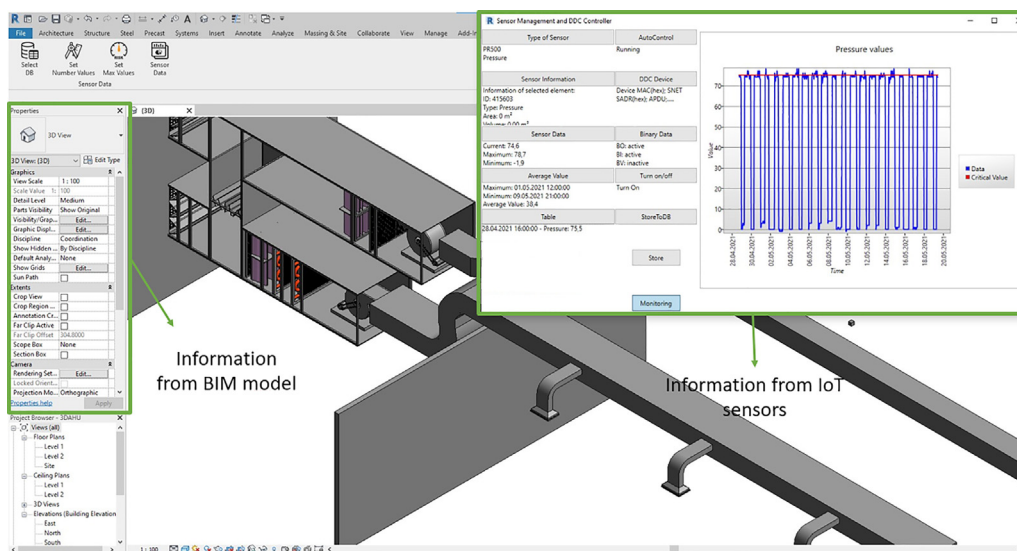

Fig. 16. The AHU information from sensor data and BIM model.

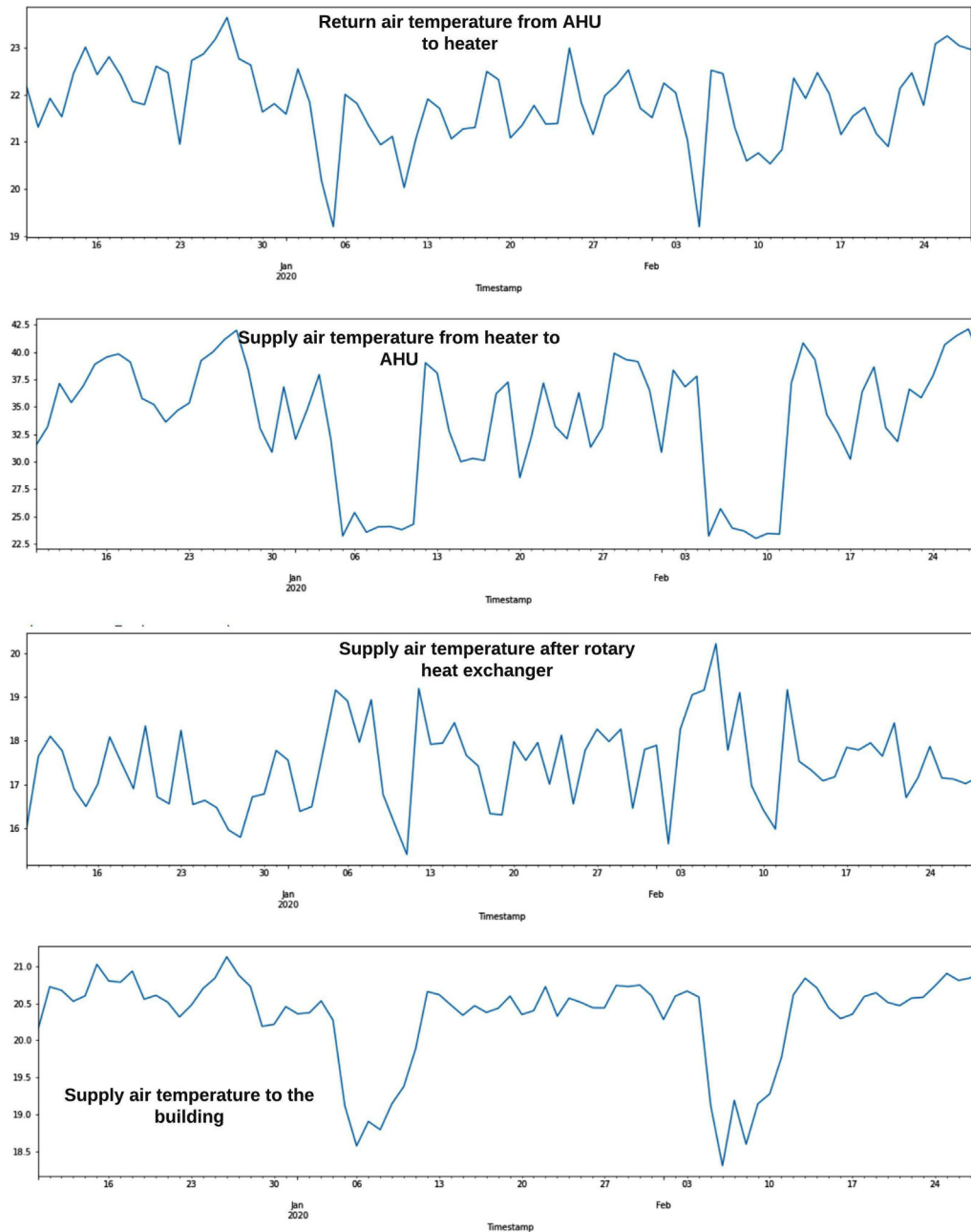

Fig. 17. Sample of sensor data from a single AHU.

tional status of each AHU in the building. The abnormal occurrences and alerts that have been recorded in the FM system are utilized as references for condition evaluation based on the results of condition monitoring. Furthermore, FM staff completed the AHU configuration list in accordance with the results of the field inspection, as shown in Fig. 18. Finally, the facility manager inspected the AHU to determine its general condition.

Several serious faults were discovered during testing based on the export rules mentioned in [105,29], which were validated by facility management staff and by analyzing the collected data. Table 5 provides an overview of operational faults. The frequency with which the problem arises can be determined based on the duration. Even though some mistakes are less severe than others, some must be corrected as quickly as possible (simultaneous heating and cooling or troubles with recuperator control). It is neces-

sary to revise the appropriate algorithms in the control system to resolve these issues.

In the next section, examples of the most severe operational errors in detail, including their subsequent solution, are illustrated. A shorter period is displayed for clarity.

### 3.6. Diagnosis of the detected faults-examples

#### 3.6.1. Heating and cooling

Fig. 19 shows the detection of simultaneous heating and cooling in a day in winter season (29th of January 2021). If the supply air temperature setpoint is greater than the external air temperature, the air handling unit is configured to operate in the winter season. As a result, the AHU is presumed to be operating in the winter mode, as the outdoor air must be heated before being delivered

**Table 4**  
Top important feature variables for AHU FDD using ANOVA.

Index	Description
1	Return air temperature
2	Supply air temperature
3	Pressure difference on filter outdoor air
4	Cooling water valve position
5	Heating water temperature
6	Heating water valve position
7	Outside air temperature
8	Cooling water temperature
9	Exhaust air valve position
10	Fresh air valve position
11	Fan exhaust air situation
12	Fan fresh air situation
13	Cooling water pump situation
14	Heating water pump situation
15	Heat recovery bypass position
16	Pressure difference on filter return air
17	Exhaust air damper position
18	Fresh air damper position

**Table 5**  
Total detected faults based on APAR method.

Number of fault	Name of Fault
Fault 1	Dampers are closed during heating regime
Fault 2	Dampers are closed during cooling regime
Fault 3	Dampers are closed during ventilate regime
Fault 4	Heating valve is closed during heating regime
Fault 5	Cooling valve is closed during cooling regime
Fault 6	Heating pump is OFF during heating regime
Fault 7	Heating pump is ON during ventilate regime
Fault 8	Cooling pump is ON during heating regime
Fault 9	Heating valve is ON during ventilate regime
Fault 10	Heating valve is stuck on 50 % during heating regime
Fault 11	Heating valve is open to the maximum level during heating regime
Fault 12	Fans are OFF during heating regime
Fault 13	Both tubes of differential pressure sensor disconnected
Fault 14	Tube of differential pressure sensor disconnected (negative pressure)
Fault 15	Quick regimes cycling
Fault 16	Heating pump is ON and valve is opened during ventilate regime
Fault 17	Heating pump is OFF during humidifying regime
Fault 18	Heating valve is OFF during humidifying regime
Fault 19	Zone inlet temperature sensor reports -20°C
Fault 20	Zone inlet temperature sensor reports 150°C
Fault 21	Zone outlet temperature sensor reports -20° C
Fault 22	Zone outlet temperature sensor reports 150°C
Fault 23	Heat exchanger is closed
Fault 24	Cooling valve is stuck on 50 % during cooling regime
Fault 25	Cooling valve is open to the maximum level during cooling regime

Systemnr/Tjeneste	Betjener	Plassering	Installert	Tilstandsgrad	Konsekvensgrad
360-10	BYGG A AKSE 4-7 PLAN 3-NORD	VENTILASJONSROM A3 110-PL 3	2017	0	0
360-11	BYGG A AKSE 7-10 DEL 2	Ventilasjonsrom A4 031 PL-4	2010	0	0
360-12	BYGG A AUDITORIE	A4 031-PL 4	2010	0	0
360-13	Bygg Akse AB-AE / 5-10 DEL 2B	Ventilasjonsrom A4 031-PL 4	2010	0	0
360-14	BYGG A AKSE 10-12 DEL 3	VENTILASJONSROM A4 031-PL 4	2010	0	0
360-15	BYGG A AKSE 12-14	Ventilasjonsrom A4 032 PL-4	2010	0	0
360-16	BYGG A AKSE 12-14 PLAN 1 - V GARDEROBE	Ventilasjonsrom A1 052 Garderobe	2010	0	0
360-20	BYGG B Gata DEL 2	VENTILASJONSROM PL-3 V Kjøkken	2010	0	0
360-30	BYGG C AKSE 1-6 DEL 1	VENTILASJONSROM PLAN 6	2010	0	0
360-31	BYGG C AUDITORIE	VENTILASJONSROM PLAN 6	2010	0	0
360-32	BYGG C AKSE 6-12 DEL 2	VENTILASJONSROM PLAN 6	2010	0	0
360-33	BYGG C KJØKKEN DEL 2	Ventilasjonsrom PLAN-3 V. KJØKKEN	2010	0	0
360-40	BYGG D AKSE 1-6 DEL 1	VENTILASJONSROM PL4- akse 5-6	2010	0	0
360-41	BYGG D AKSE 6-11 DEL 2	Ventilasjonsrom PL-4-Akse 6-7	2010	0	0
360-42	Bygg D		2015	0	0
360-43	BYGG D		2010	0	0
360-50	BYGG E VENTROM	Vent.Rom Underetasje	2010	0	0

**Fig. 18.** Example of a service report from GK Inneklima AS for AHU in I4Helse.

to the inhabitants. When the AHU is in fault-free mode, the following requirements must be met: (1) The cooling valve (SB402) should be closed; (2) The supply air setpoint temperature should be higher than the outside air temperature; (3) The temperature of the air after the heating coil should be approximately equal to the temperature of the supply air minus the temperature rise due to the supply air fan. However, as can be seen in Fig. 19, both heater valve (SB401) and chiller valve (SB402) are opened. While simultaneous heating and cooling do not affect interior comfort, it is very wasteful in terms of energy usage. Clearly, there is a severe flaw in the control system, and this should never have happened.

### 3.6.2. Unexpected heating

Test checks states of heater, chiller, humidifier and recuperation. AHU is in a heating regime (25th of February 2021). A fault is reported if the heater valve is closed (SB401), the heating pump is off, the chiller valve is opened (SB402), the cooling pump is on, or the full potential of recuperation is not used (LX401). The pressure of exhaust air (PR500) and supply air pressure (RP400) are shown in Fig. 20. The supply air temperature (RT400) is much higher than the setpoint (supply air temperature setpoint) (Fig. 20). All supply air should flow through the bypass damper, and the heating valve (SB401) should be closed. None of this is happening.

### 3.6.3. Heat conservation cool

Test checks if there is an uncontrolled transfer of heat, cold or moisture to the supply air when flowing through the air handling unit. A fault is reported if the AHU is in the cooling regime and supply air temperature (RT400) is higher than the outside temperature (AHU1 odata) (Fig. 21). This fault often happened in November and December 2020 and January 2021 (before the significant change on 10th February 2021). In this case, the chiller valve (SB402) should be closed. The outside temperature is low enough to cool supply air.

## 3.7. Failure prediction in AHUs

### 3.7.1. Key metrics for evaluation

We tested the suggested AHU predictive maintenance technique using real-world samples from our buildings with data augmentation methods. Data from BIM models, IoT sensor networks, and FM systems are collected in three groups in each data set. There are four steps in the prediction process:

- Training randomly 80% of entire data sets containing 25 types of faults (Table 5) detected based on APAR from around 150 000 data points.

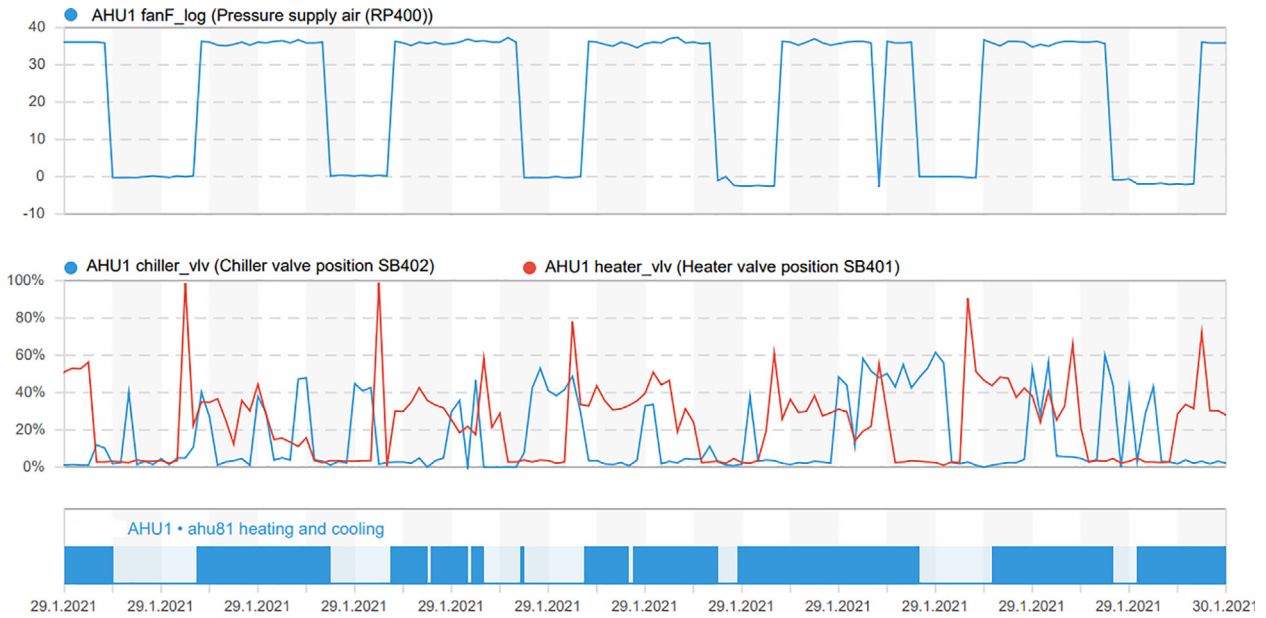

Fig. 19. Simultaneous heating and cooling fault.

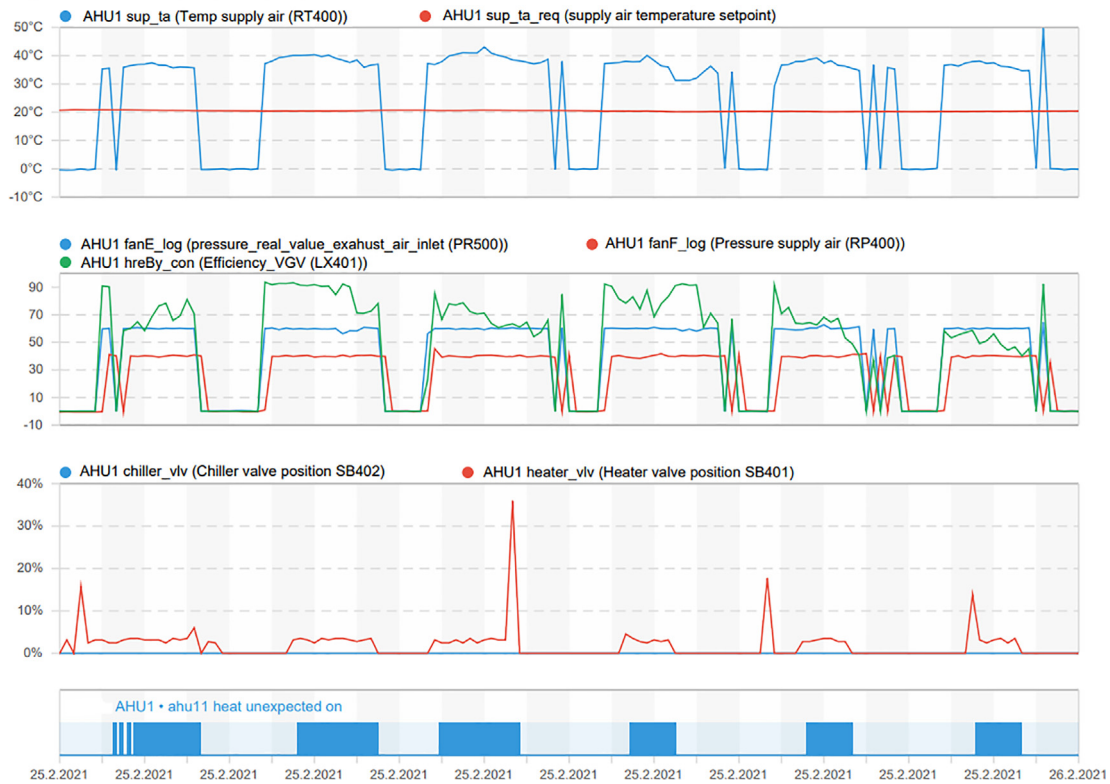

Fig. 20. Heat unexpected on fault.

- Holdout validation using 10% of total data sets.
- Testing and prediction using 10% of total data sets.
- Prediction of faults for the next month and 4.5 months.

The algorithms artificial neural network (ANN), support vector machine (SVM), and decision trees are used to predict and evaluate severe AHU faults.

Two specific assessment measures are utilized for experimental comparison, namely class-specific metrics and performance Trade-off Evaluation.

Consider that there are N classes, each with an index ranging from 1 to N. Class-specific metrics measure the classifier's performance concerning a given class k, where  $k: 1 \leq k \leq N$ . The positive class is k, while the rest of the classes are grouped as a negative



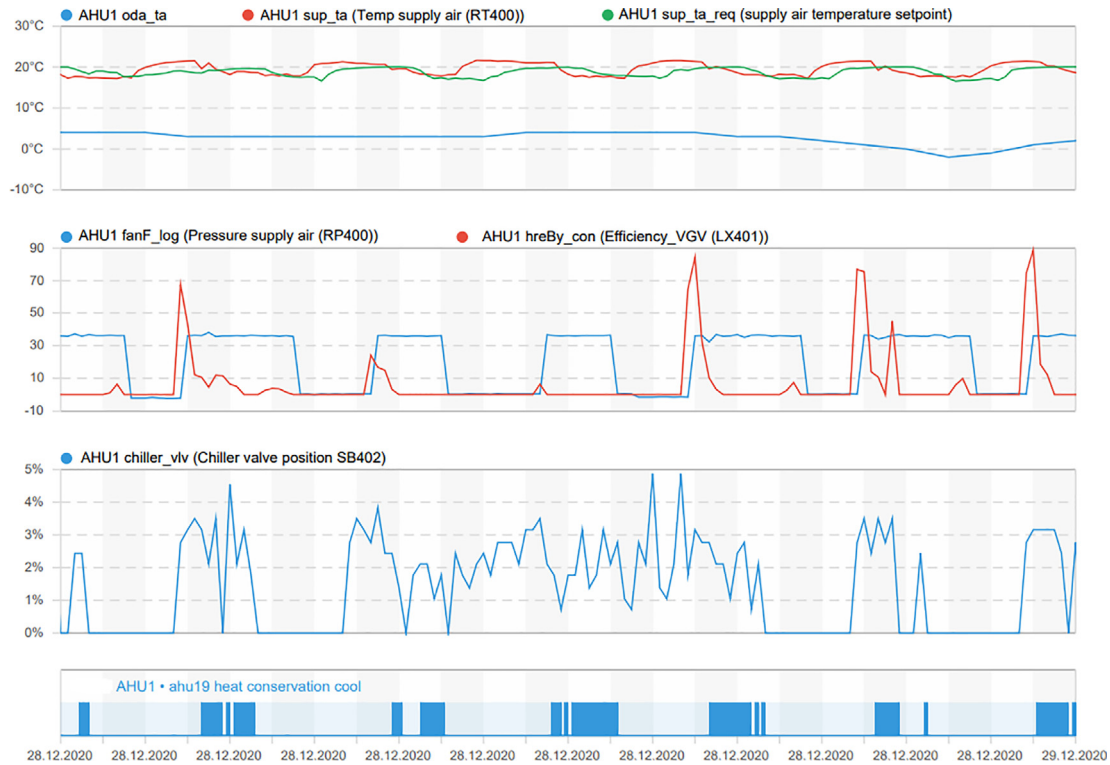

Fig. 21. Heat conservation cool fault.

Table 6

Predictive totals by class. The confusion matrix can be used to determine the predicted totals for class k. True Positives are contained within the diagonal entry row k, column k, False Negatives are contained within the remaining entries in row k, False Positives are contained within the remaining entries in column k, and True Negatives are included within the remaining entries in the matrix.

True Positives	TPk	The number of responses equal to class k that were correctly predicted as class k.
True Negatives	TNk	The number of responses not equal to class k that were correctly predicted as not equal to class k.
False Positives	FPk	The number of responses not equal to class k that were incorrectly predicted as class k.
False Negatives	FNk	The number of responses equal to class k that were incorrectly predicted as not class k.

class. The metrics measure the classifier’s performance with class k, one vs. all others. (Table 6). The confusion matrix concept can be seen in Fig. 22. In addition, The Receiver Operating Characteristic curve (ROC) for class k and the Area Under the Curve for class k are frequently used to evaluate a model and its trade-off as functions of the threshold value [109].

3.7.2. An evaluation of predictive maintenance strategies

The predicted conditions of AHU using the ANN, SVM and decision trees algorithms are compared. Data sets (10% of the total data sets) are used for testing. The prediction accuracy of the best decision tree was Fine Tree is 99.9% better than SVM (99.5%) and ANN (99.7%). The condition prediction was carried out on the same datasets as the comparative performance analysis to guarantee that the results of the comparative performance analysis of these approaches were applicable to a wide range of situations. However, accuracy alone is not a reliable predictor of which algorithm is the most effective. As previously said, we will compare two variables using the confusion matrix and the receiver operating characteristic (ROC). Based on that, the Fine tree misclassified 4 faults (damper are closed during heating regime, heating pump is off during

heating regime, heating pump is on and valve is opened during ventilation regime, and quick regime cycling) and AUC value from the ROC was equal to 0.49. The SVM method has also misclassified 5 faults (heat exchanger is closed, heating pump is off during heating regime, heating valve is closed during heating regime, heating valve is stuck in intermediate position during heating regime, quick regime cycling) with AUC value equal to 1. However, ANN was able to classify all faults correctly and with AUC equal to 1. Hence, ANN outperforms both SVM and Fine trees, and the ROC curves also indicate this, with the area under the curve for Fine trees being half that of the area under the curve for the ANN. So the prediction accuracy and error indices of decision trees, ANN, and SVM all indicate that ANN outperforms the other two methods even if it requires a longer time (147.05 s) than SVM (53.756 s) and Fine Tree (3.8745 s).

3.7.3. Maintenance planning

The trained ANN model is chosen to forecast the future state of the AHUs based on a comparison of ANN, SVM, and decision trees techniques. The suggested framework is capable of predicting future conditions at a certain point in time. We use one month

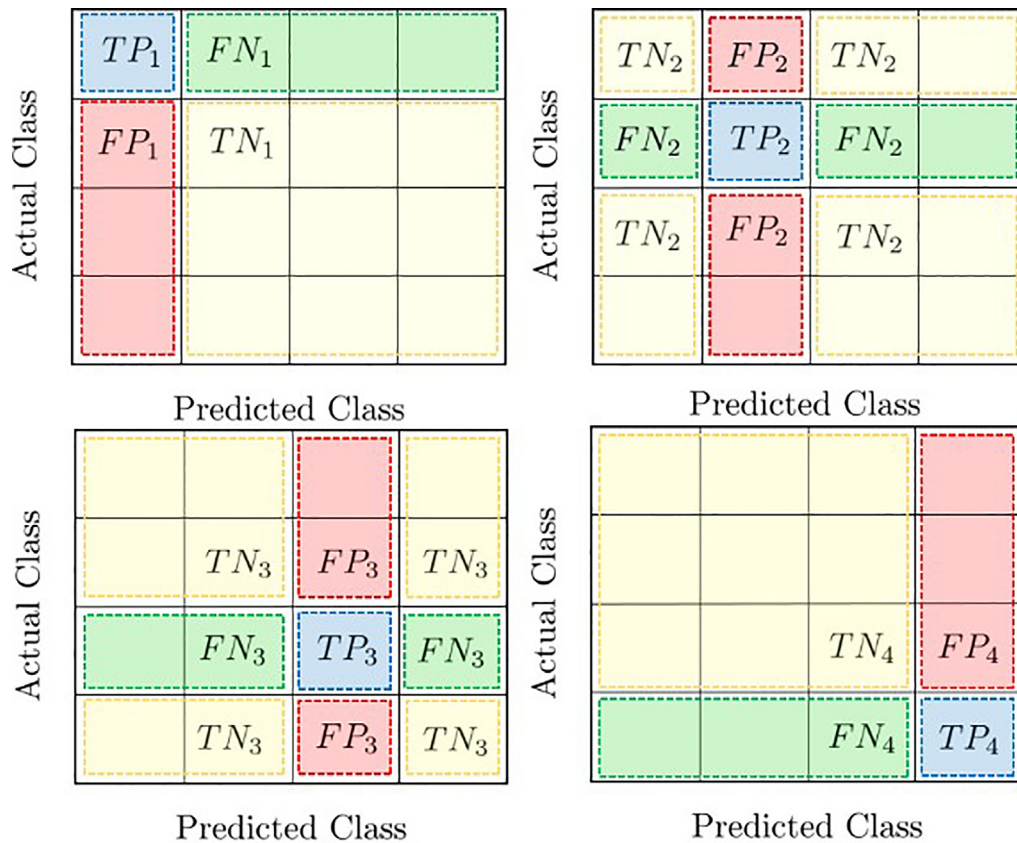

Fig. 22. Multiclass confusion matrix [109].

and 4.5 months later as an example for future maintenance planning and illustrate the dynamic maintenance planning that goes with it. For one month scenario, Table 7 and Fig. 23 show the detected faults and the faults that were wrongly predicted, where x refers to the actual case and y to the predicted case. For example, during one month scenario, it was predicted that the dampers will be closed during the cooling regime, where in actual case, no fault was detected. In the same way, for 4.5 months scenario, Table 8

Table 7  
Fault prediction for one month later; 29-05-2021 to 29-06-2021

Type	Accuracy%	Error%
Cooling valve is closed during cooling regime	87.5	12.5
Damper are closed during cooling regime	80.0	20
Heating valve is ON during ventilation regime	100	0
No faults	99.8	0.2

Table 8  
Fault prediction for 4.5 months later; 29-05-2021 to 15-10-2021

Type	Accuracy%	Error%
Cooling pump is ON during heating regime	100	0.0
Cooling valve is closed during cooling regime	87.5	12.5
Damper are closed during cooling regime	80.0	20
Damper are closed during ventilation regime	80.0	20
Heater exchanger is closed	71.4	28.6
Heating pump is ON, and valve is opened during ventilation regime	100	0.0
Heating valve is ON during ventilation regime	100	0.0
Heating valve is open to the maximum level during cooling regime	0.0	100
Heating valve is open to the maximum level during heating regime	0.0	100
No faults	99.9	0.1

and Fig. 24 shows the predicted faults, where the algorithm misclassified some faults comparing to the actual case like the faults in heat exchanger.

As a result, the facility manager should prepare maintenance equipment, materials, and tools ahead of time rather than repairing after failure, depending on the expected condition. Because the situation will deteriorate gradually over the following nine months, monthly examination and minimal maintenance will suffice. Overall, a predictive maintenance approach allows the facility manager to track changes in degradation and condition and plan tools and time accordingly. Each expected action causes a change in maintenance planning.

#### 4. Discussion

There have been several studies on various techniques for identifying HVAC problems since the 1980s. Despite this fact, Fault detection is still not a standard part of HVAC operations. The rea-

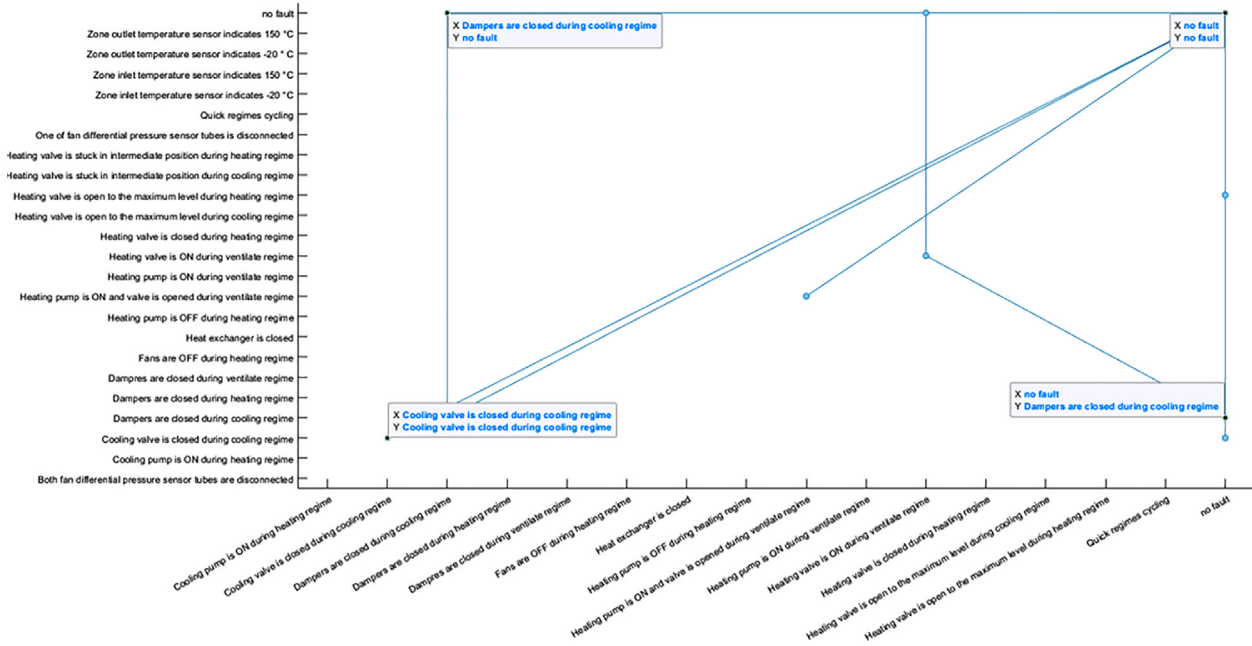

Fig. 23. Comparison between the actual and predicted faults for June 2021 using ANN model (one month ahead from the data that used for training and validation between August 2019 and May 2021) where x refers to the actual fault and y to the predicted fault.

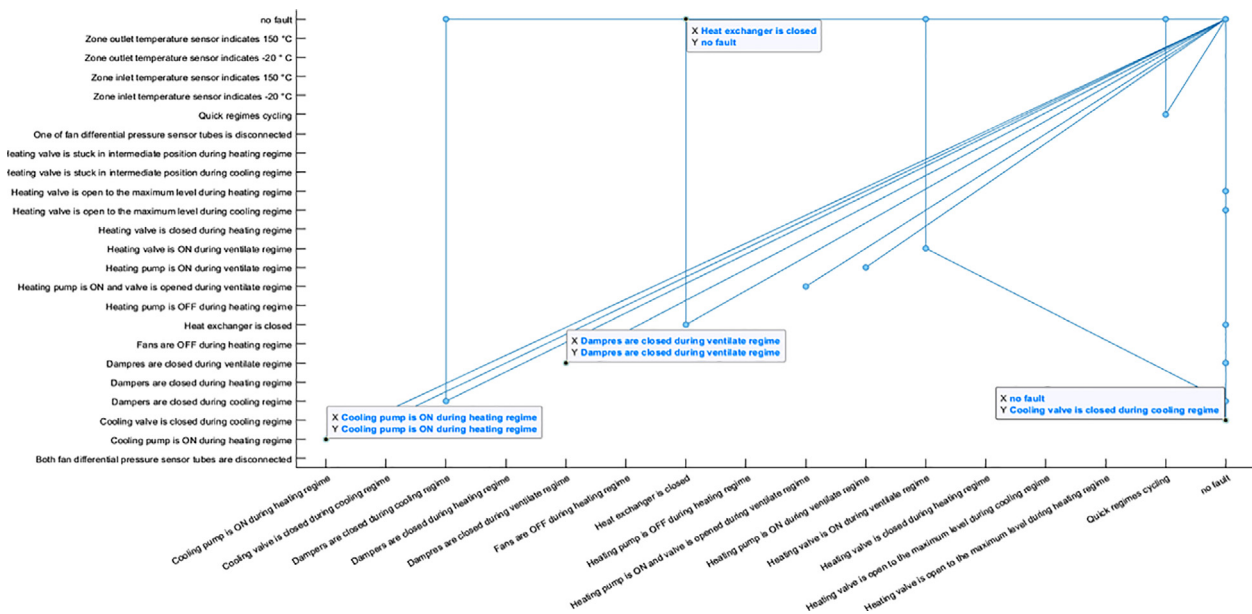

Fig. 24. Comparison between the actual and predicted faults for June, July, August, September and October 2021 using ANN model (4.5 months ahead from the data that used for training and validation between August 2019 and May 2021) where x refers to the actual fault and y to the predicted fault.

son is the restricted flexibility of fault detection methods and the high cost of fault detection systems. As previously indicated, to solve this issue, we used a modular AHU fault detection system that can be utilized with a wide range of AHUs.

This article describes a rule-based system for FDD. It is appropriate for AHU and other HVAC system components, such as the electrical and plumbing systems. This work aims not to obtain the highest possible success rate in fault detection for a single AHU but rather to achieve a fair detection rate for many AHUs. However, the authors state that making comparisons and comprehending the overall condition of technology are complex tasks since each study project uses a particular dataset, test settings, and measurements.

When the facility manager employs the suggested framework in the practical process, it is not required to compare different prediction techniques. Predictive maintenance strategies utilizing ANN, decision trees and SVM techniques are demonstrated in this study to show how to implement a predictive maintenance plan using this framework. It can be seen from the comparative example that different prediction algorithms will produce results with varying accuracy and processing times. Furthermore, the results of the predictions are dependent not only on the quality and the number of datasets gathered but also on the algorithms that have been chosen.

In this study, data integration and flow is accomplished through the use of a plug-in and Brick schema. Other possible solutions to

the data integration problems are to include different sensors, equipment, and building components, among other things, in one ontology. Even more significantly, the rising relevance of semantic data in building management systems will be critical in expanding fault detection approaches. It is anticipated that semantic data will become a common element of business management systems within a few years. Agarwal et al. [110] identified many critical ideas from several popular ontologies that may be used for data integration, such as, Semantic Sensor Networks (SSN). As a result, the ontology-based approach may prove to be a viable option for data integration, standardization, and synchronization in the future, among other things. It is expected that as a consequence, the use of fault detection technologies will become extremely easy, inexpensive, and a common element of building management systems.

## 5. Conclusions

The article examines how the Digital Twin may assist predictive maintenance and dynamic maintenance strategy in the FMM process. The design of the proposed framework includes the data integration and data flow processes between BIM models, IoT sensor networks, and the FM system. The use of three modules implements predictive maintenance: (1) operational fault detection, (2) condition prediction, and (3) maintenance planning. Furthermore, several machine learning techniques (ANN, SVM, and decision trees) are used to forecast the components' state to maintain or repair them in advance and to increase the lifetime of AHU components.

According to the findings of this study, the method of automated fault detection in AHUs has proven to be both functional and beneficial. The system has a high success rate even though it detects a wide variety of different problems and a variety of different AHUs. Moreover, the authors discuss data sources and a semantic definition of data and methods for fault detection and repair.

The limitations of this paper are as follows: The selection of the algorithm depends on the developer's previous experience, which will impact the prediction outcomes. In future investigations, it will be necessary to investigate alternative prediction approaches. Future research should adopt an ontology approach to build a new data model that will establish a standardized data integration solution among various types of sensors and application systems. It is also crucial to further investigate the incremental learning methods of the prediction models to extend the existing model's knowledge, i.e., to train the model further and keep updating the input data.

## CRediT authorship contribution statement

**Haidar Hosamo Hosamo:** Conceptualization, Methodology, Software, Data curation, Validation, Formal analysis, Visualization, Writing – original draft, Writing – review & editing. **Paul Ragnar Svennevig:** Supervision, Writing – review & editing. **Kjeld Svidt:** Supervision, Conceptualization. **Daguang Han:** Methodology, Visualization. **Henrik Kofoed Nielsen:** Supervision, Methodology, Resources, Writing – review & editing.

## Declaration of Competing Interest

The authors declare that they have no known competing financial interests or personal relationships that could have appeared to influence the work reported in this paper.

## Acknowledgement

The work presented in this journal paper is funded by Scandinavian Sustainable Circular Construction (S2C) and the University of Agder. The authors appreciate all of the contributors for their gracious support and input. Special thanks to Letizia Pastorello for her help with C# and Windows Presentation Foundation (WPF) programming.

## References

- [1] McGraw-Hill, Energy Efficiency Trends in Residential and Commercial Buildings – August 2010, Tech. Rep. 1218835, McGraw-Hill (Aug. 2010). doi:10.2172/1218835..
- [2] L. Pérez-Lombard, J. Ortiz, C. Pout, A review on buildings energy consumption information, *Energy Build.* 40 (3) (2008) 394–398, <https://doi.org/10.1016/j.enbuild.2007.03.007>.
- [3] F. Xiao, S. Wang, Progress and methodologies of lifecycle commissioning of HVAC systems to enhance building sustainability, *Renew. Sustain. Energy Rev.* 13 (5) (2009) 1144–1149, <https://doi.org/10.1016/j.rser.2008.03.006>.
- [4] N.E.P. Fernandez, S. Katipamula, W. Wang, Y. Xie, M. Zhao, C.D. Corbin, Impacts of Commercial Building Controls on Energy Savings and Peak Load Reduction, Tech. Rep. PNNL-25985, Pacific Northwest National Lab. (PNNL), Richland, WA (United States) (May 2017). doi:10.2172/1400347..
- [5] J. Granderson, G. Lin, R. Singla, E. Mayhorn, P. Ehrlich, D. Vrabie, S. Frank, Commercial Fault Detection and Diagnostics Tools: What They Offer, How They Differ, and What's Still Needed, Lawrence Berkeley National Laboratory doi:10.20357/B7V88H..
- [6] M.A. Piette, S.K. Kinney, P. Haves, Analysis of an information monitoring and diagnostic system to improve building operations, *Energy Build.* 33 (8) (2001) 783–791, [https://doi.org/10.1016/S0378-7788\(01\)00068-8](https://doi.org/10.1016/S0378-7788(01)00068-8).
- [7] C.M. Eastman, C. Eastman, P. Teicholz, R. Sacks, K. Liston, B.I.M. Handbook, A Guide to Building Information Modeling for Owners, Managers, Designers, Engineers and Contractors, John Wiley & Sons, 2011.
- [8] R.K. Mobley, An Introduction to Predictive Maintenance, Elsevier, 2002.
- [9] B. Atkin, A. Brooks, Total Facility Management, John Wiley & Sons (2021), google-Books-ID: 09QnEAAAQBAJ.
- [10] D. Sapp, Facilities Operations & Maintenance – An Overview – WBDG – Whole Building Design Guide (2017). URL: <https://www.wbdg.org/facilities-operations-maintenance..>
- [11] R. Edirisinghe, K.A. London, P. Kalutara, G. Aranda-Mena, Building information modelling for facility management: are we there yet?, *Eng. Constr. Archit. Manage.* 24(6) (2017) 1119–1154, publisher: Emerald Publishing Limited. doi:10.1108/ECAM-06-2016-0139..
- [12] P. Parsanezhad, J. Dimyadi, Effective Facility Management and Operations via a BIM-based Integrated Information System, CIB W070 (2014), <https://doi.org/10.13140/2.1.2298.9764>.
- [13] S.H. Alavi, N. Forcada, BIM LOD for facility management tasks, in: Proceedings of the 2019 European Conference on Computing in Construction, Vol. 1 of Computing in Construction, University College Dublin, Chania, Crete, 2019, pp. 154–163. doi:10.35490/ec3.2019.187..
- [14] R. Volk, J. Stengel, F. Schultmann, Building Information Modeling (BIM) for existing buildings - Literature review and future needs, *Autom. Constr.* 38 (2014) 109–127, <https://doi.org/10.1016/j.autcon.2013.10.023>.
- [15] L. Ding, R. Drogemuller, P. Akhurst, R. Hough, S. Bull, C. Linning, Toward sustainable facilities management, in: Technology, Design and Process Innovation in Built Environment, Taylor & Francis, 2009, pp. 373–392..
- [16] L. Sabol, Challenges in Cost Estimating with Building Information Modeling, *Design Constr. Strategies* (2008) 17.
- [17] M. Das, J.C. Cheng, K.H. Law, An ontology-based web service framework for construction supply chain collaboration and management, *Eng. Constr. Archit. Manage.* 22(5) (2015) 551–572, publisher: Emerald Group Publishing Limited. doi:10.1108/ECAM-07-2014-0089..
- [18] Y. Deng, J.C.P. Cheng, C. Anumba, Mapping between BIM and 3D GIS in different levels of detail using schema mediation and instance comparison, *Autom. Constr.* 67 (2016) 1–21, <https://doi.org/10.1016/j.autcon.2016.03.006>.
- [19] About – IEA EBC (2021). URL: <https://www.iea-ebc.org/ebc/about..>
- [20] S. Katipamula, M. Brambley, Review Article: Methods for Fault Detection, Diagnostics, and Prognostics for Building Systems-A Review, Part I, HVAC&R Res. 11 (1) (2005) 3–25, <https://doi.org/10.1080/10789669.2005.10391123>.
- [21] J. Hyvärinen, I.E. Agency (Eds.), Building optimization and fault diagnosis source book: IEA annex 25; Real time simulation of HVAC systems for building optimisation, fault detection and diagnosis, International Energy Agency, Espoo, 1996.
- [22] A. Dexter, J. Pakanen, Demonstrating Automated Fault Detection and Diagnosis Methods in Real Buildings: International Energy Agency. Energy Conservation in Buildings and community Systems ANNEX 34, VTT Technical Research Centre of Finland, 2001.
- [23] C.Y. Leong, Fault Detection and Diagnosis of Air Handling Unit: A Review, MATEC Web of Conferences 255 (2019) 06001, publisher: EDP Sciences. doi:10.1051/mateconf/201925506001..
- [24] Y. Zhao, J. Wen, F. Xiao, X. Yang, S. Wang, Diagnostic Bayesian networks for diagnosing air handling units faults - part I: Faults in dampers, fans, filters

- and sensors, *Appl. Therm. Eng.* 111 (2017) 1272–1286, <https://doi.org/10.1016/j.applthermaleng.2015.09.121>.
- [25] M.S. Mirnaghi, F. Haghghat, Fault detection and diagnosis of large-scale HVAC systems in buildings using data-driven methods: A comprehensive review, *Energy Build.* 229 (2020), <https://doi.org/10.1016/j.enbuild.2020.110492> 110492.
- [26] Y. Li, Z. O'Neill, A critical review of fault modeling of HVAC systems in buildings, *Build. Simul.* 11 (5) (2018) 953–975, <https://doi.org/10.1007/s12273-018-0458-4>.
- [27] H. Yang, T. Zhang, H. Li, D. Woradechjumroen, X. Liu, H.V.A.C. Equipment, Unitary: Fault Detection and Diagnosis, *Encyclopedia of Energy, Eng. Technol.* 4 (2014) 854–864, <https://doi.org/10.1081/E-EEE2-120051345>.
- [28] Home – BrickSchema (2021). URL: <https://brickschema.org/>.
- [29] O. Nehasil, L. Dobiášová, V. Mazanec, J. Široký, Versatile AHU fault detection - Design, field validation and practical application, *Energy Build.* 237 (2021), <https://doi.org/10.1016/j.enbuild.2021.110781>.
- [30] M.M. Mabkhot, A.M. Al-Ahmari, B. Salah, H. Alkhalefah, Requirements of the Smart Factory System: A Survey and Perspective, *Machines* 6 (2) (2018) 23, number: 2 Publisher: Multidisciplinary Digital Publishing Institute. doi:10.3390/machines6020023.
- [31] A.M. Madni, C.C. Madni, S.D. Lucero, Leveraging Digital Twin Technology in Model-Based Systems Engineering, *Systems* 7 (1) (2019) 7, number: 1 Publisher: Multidisciplinary Digital Publishing Institute. doi:10.3390/systems7010007.
- [32] C. Boje, A. Guerriero, S. Kubicki, Y. Rezgui, Towards a semantic Construction Digital Twin: Directions for future research, *Autom. Constr.* 114 (2020), <https://doi.org/10.1016/j.autcon.2020.103179> 103179.
- [33] Q. Qi, F. Tao, Digital Twin and Big Data Towards Smart Manufacturing and Industry 4.0: 360 Degree Comparison, *IEEE Access* 6 (2018) 3585–3593, conference Name: IEEE Access. doi:10.1109/ACCESS.2018.2793265.
- [34] J. Autiosalo, J. Vepsäläinen, R. Viitala, K. Tammi, A Feature-Based Framework for Structuring Industrial Digital Twins, *IEEE Access* 8 (2020) 1193–1208, conference Name: IEEE Access. doi:10.1109/ACCESS.2019.2950507.
- [35] W. Kritzinger, M. Karner, G. Traar, J. Henjes, W. Sihn, Digital Twin in manufacturing: A categorical literature review and classification, *IFAC-PapersOnLine* 51 (11) (2018) 1016–1022, <https://doi.org/10.1016/j.ifacol.2018.08.474>.
- [36] J. Lee, E. Lapira, B. Bagheri, H.-A. Kao, Recent advances and trends in predictive manufacturing systems in big data environment, *Manufacturing Lett.* 1 (1) (2013) 38–41, <https://doi.org/10.1016/j.mfglet.2013.09.005>.
- [37] M. Grieves, J. Vickers, Digital Twin: Mitigating Unpredictable, Undesirable Emergent Behavior in Complex Systems, in: F.-J. Kahlen, S. Flumerfelt, A. Alves (Eds.), *Transdisciplinary Perspectives on Complex Systems: New Findings and Approaches*, Springer International Publishing, Cham, 2017, pp. 85–113, [https://doi.org/10.1007/978-3-319-38756-7\\_4](https://doi.org/10.1007/978-3-319-38756-7_4).
- [38] F. Longo, L. Nicoletti, A. Padovano, Ubiquitous knowledge empowers the Smart Factory: The impacts of a Service-oriented Digital Twin on enterprises' performance, *Annu. Rev. Control* 47 (2019) 221–236, <https://doi.org/10.1016/j.arcontrol.2019.01.001>.
- [39] M. Vathooan, M. Johny, A. Zoitl, A. Knoll, Modular Fault Ascription and Corrective Maintenance Using a Digital Twin, *IFAC-PapersOnLine* 51 (11) (2018) 1041–1046, <https://doi.org/10.1016/j.ifacol.2018.08.470>.
- [40] S. Poppi, C. Bales, M.Y. Haller, A. Heinz, Influence of boundary conditions and component size on electricity demand in solar thermal and heat pump combisystems, *Appl. Energy* 162 (2016) 1062–1073, <https://doi.org/10.1016/j.apenergy.2015.10.190>.
- [41] Y.-C. Su, Y.C. Lee, Y.C. Lin, Enhancing Maintenance Management Using Building Information Modeling in Facilities Management, in: *Proceedings of the 28th ISARC*, 2011, pp. 752–757. doi:10.22260/ISARC2011/0140.
- [42] A. Motamedi, A. Hammad, Y. Asen, Knowledge-assisted BIM-based visual analytics for failure root cause detection in facilities management, *Autom. Constr.* 43 (2014) 73–83, <https://doi.org/10.1016/j.autcon.2014.03.012>.
- [43] W. Chen, K. Chen, J.C.P. Cheng, Q. Wang, V.J.L. Gan, BIM-based framework for automatic scheduling of facility maintenance work orders, *Autom. Constr.* 91 (2018) 15–30, <https://doi.org/10.1016/j.autcon.2018.03.007>.
- [44] C. Koch, M. Neges, M. König, M. Abramovici, Natural markers for augmented reality-based indoor navigation and facility maintenance, *Autom. Constr.* 48 (2014) 18–30, <https://doi.org/10.1016/j.autcon.2014.08.009>.
- [45] S. Lee, Á. Akin, Augmented reality-based computational fieldwork support for equipment operations and maintenance, *Autom. Constr.* 20 (4) (2011) 338–352, <https://doi.org/10.1016/j.autcon.2010.11.004>.
- [46] Q. Hao, Y. Xue, W. Shen, B. Jones, J. Zhu, A Decision Support System for Integrating Corrective Maintenance, Preventive Maintenance, and Condition-Based Maintenance, *ASCE* (2012) 470–479. Publisher: American Society of Civil Engineers. doi:10.1061/41109(373)47.
- [47] J.C.P. Cheng, W. Chen, Y. Tan, M. Wang, A BIM-based Decision Support System Framework for Predictive Maintenance Management of Building Facilities, in: *The 16th International Conference on Computing in Civil and Building Engineering (ICCCBE2016)*, 2016, p. 8.
- [48] J. Wang, L. Zhang, L. Duan, R.X. Gao, A new paradigm of cloud-based predictive maintenance for intelligent manufacturing, *J. Intell. Manuf.* 28 (5) (2017) 1125–1137, <https://doi.org/10.1007/s10845-015-1066-0>.
- [49] B. Schmidt, L. Wang, Cloud-enhanced predictive maintenance, *Int. J. Adv. Manuf. Technol.* 99 (1) (2018) 5–13, <https://doi.org/10.1007/s00170-016-8983-8>.
- [50] S. Ren, X. Zhao, A predictive maintenance method for products based on big data analysis, in: *Advances in Engineering Research*, Atlantis Press, 2015, pp. 385–390, ISSN: 2352–5401. doi:10.2991/meita-15.2015.71.
- [51] F. Civerchia, S. Bocchino, C. Salvadori, E. Rossi, L. Maggiani, M. Petracca, Industrial Internet of Things monitoring solution for advanced predictive maintenance applications, *J. Ind. Inf. Integr.* 7 (2017) 4–12, <https://doi.org/10.1016/j.jii.2017.02.003>.
- [52] K. Wang, Y. Wang, How AI Affects the Future Predictive Maintenance: A Primer of Deep Learning, in: K. Wang, Y. Wang, J.O. Strandhagen, T. Yu (Eds.), *Advanced Manufacturing and Automation VII, Lecture Notes in Electrical Engineering*, Springer, Singapore, 2018, pp. 1–9, [https://doi.org/10.1007/978-981-10-5768-7\\_1](https://doi.org/10.1007/978-981-10-5768-7_1).
- [53] F. Francis, M. Mohan, ARIMA Model based Real Time Trend Analysis for Predictive Maintenance, 2019 Communication and Aerospace Technology (ICECA) (2019) 735–739, <https://doi.org/10.1109/ICECA.2019.8822191>.
- [54] J.J. Hopfield, Neural networks and physical systems with emergent collective computational abilities, *Proc. Natl. Acad. Sci.* 79(8) (1982) 2554–2558, publisher: National Academy of Sciences Section: Research Article. doi:10.1073/pnas.79.8.2554.
- [55] J. Shao, Application of an artificial neural network to improve short-term road ice forecasts, *Expert Syst. Appl.* 14 (4) (1998) 471–482, [https://doi.org/10.1016/S0957-4174\(98\)00006-2](https://doi.org/10.1016/S0957-4174(98)00006-2).
- [56] M.S. El-Abbasy, A. Senouci, T. Zayed, F. Mirahadi, L. Parvizesdghy, Artificial neural network models for predicting condition of offshore oil and gas pipelines, *Autom. Constr.* 45 (2014) 50–65, <https://doi.org/10.1016/j.autcon.2014.05.003>.
- [57] A. Silva, J.L. Dias, P.L. Gaspar, J. de Brito, Statistical models applied to service life prediction of rendered façades, *Autom. Constr.* 30 (2013) 151–160, <https://doi.org/10.1016/j.autcon.2012.11.028>.
- [58] S. Biswal, G. Sabareesh, Design and development of a wind turbine test rig for condition monitoring studies, *International Conference on Industrial Instrumentation and Control (IIC) 2015* (2015) 891–896, <https://doi.org/10.1109/IIC.2015.7150869>.
- [59] T.P. Carvalho, F.A.A.M.N. Soares, R. Vita, R.D.P. Francisco, J.P. Basto, S.G.S. Alcalá, A systematic literature review of machine learning methods applied to predictive maintenance, *Comput. Ind. Eng.* 137 (2019), <https://doi.org/10.1016/j.cie.2019.106024> 106024.
- [60] G. Morcouc, Performance Prediction of Bridge Deck Systems Using Markov Chains, *J. Performance Constr. Facilities* 20 (2) (2006) 146–155, publisher: American Society of Civil Engineers. doi:10.1061/(ASCE)0887-3828(2006)20:2(146).
- [61] J. Pearl, Bayesian Networks: a model of self-activated: memory for evidential reasoning (1985). URL: [http://ftp.cs.ucla.edu/pub/stat\\_ser/r43-1985.pdf](http://ftp.cs.ucla.edu/pub/stat_ser/r43-1985.pdf).
- [62] J. Pearl, Fusion, propagation, and structuring in belief networks, *Artif. Intell.* 29 (3) (1986) 241–288, [https://doi.org/10.1016/0004-3702\(86\)90072-X](https://doi.org/10.1016/0004-3702(86)90072-X).
- [63] S. Andreassen, M. Woldbye, B. Falck, S.K. Andersen, MUNIN: a causal probabilistic network for interpretation of electromyographic findings, in: *Proceedings of the 10th international joint conference on Artificial intelligence - vol. 1, IJCAI'87*, Morgan Kaufmann Publishers Inc., San Francisco, CA, USA, 1987, pp. 366–372.
- [64] L.S. Riza, M. Pradini, E.F. Rahman, Rasim, An Expert System for Diagnosis of Sleep Disorder Using Fuzzy Rule-Based Classification Systems, *IOP Conference Series: Materials Science and Engineering* 185 (2017) 012011, publisher: IOP Publishing. doi:10.1088/1757-899X/185/1/012011.
- [65] C.W. Kang, M.W. Golay, A Bayesian belief network-based advisory system for operational availability focused diagnosis of complex nuclear power systems, *Expert Syst. Appl.* 17 (1) (1999) 21–32, [https://doi.org/10.1016/S0957-4174\(99\)00018-4](https://doi.org/10.1016/S0957-4174(99)00018-4).
- [66] N. Mehranbod, M. Soroush, C. Panjapornpon, A method of sensor fault detection and identification, *J. Process Control* 15 (3) (2005) 321–339, <https://doi.org/10.1016/j.jprocont.2004.06.009>.
- [67] A. Mokhtari, M. Ghodrati, P. Javadpoor Langroodi, A. Shahrian, Wind speed sensor calibration in thermal power plant using Bayesian inference, *Case Studies, Therm. Eng.* 19 (2020), <https://doi.org/10.1016/j.csite.2020.100621> 100621.
- [68] L. Raillon, C. Ghiaus, An efficient Bayesian experimental calibration of dynamic thermal models, *Energy* 152 (2018) 818–833, <https://doi.org/10.1016/j.energy.2018.03.168>.
- [69] M. Najafi, D.M. Auslander, P.L. Bartlett, P. Haves, M.D. Sohn, Application of machine learning in the fault diagnostics of air handling units, *Appl. Energy* 96 (2012) 347–358, <https://doi.org/10.1016/j.apenergy.2012.02.049>.
- [70] J. Wall, Y. Guo, Jiaming Li, S. West, A Dynamic Machine Learning-based Technique for Automated Fault Detection in HVAC Systems, *ASHRAE Trans.* 117(2) (2011) 449–456, publisher: ASHRAE.
- [71] Y. Zhao, F. Xiao, S. Wang, An intelligent chiller fault detection and diagnosis methodology using Bayesian belief network, *Energy Build.* 57 (2013) 278–288, <https://doi.org/10.1016/j.enbuild.2012.11.007>.
- [72] F. Xiao, Y. Zhao, J. Wen, S. Wang, Bayesian network based FDD strategy for variable air volume terminals, *Autom. Constr.* 41 (2014) 106–118, <https://doi.org/10.1016/j.autcon.2013.10.019>.
- [73] Z. Liu, Z. Huang, J. Wang, C. Yue, S. Yoon, A novel fault diagnosis and self-calibration method for air-handling units using Bayesian Inference and virtual sensing, *Energy Build.* 250 (2021), <https://doi.org/10.1016/j.enbuild.2021.111293> 111293.

- [74] J. Zhao, W. Zheng, Study of fault diagnosis method based on fuzzy Bayesian network and application in CTC3 train control system, 2013 IEEE International Conference on Intelligent Rail Transportation Proceedings (2013) 249–254, <https://doi.org/10.1109/ICIRT.2013.6696302>.
- [75] Construction and applications in data mining of bayesian networks–Journal of Tsinghua University(Science and Technology) 2001-01 (2001)..
- [76] L. Breiman, Random Forests, *Mach. Learn.* 45 (1) (2001) 5–32, <https://doi.org/10.1023/A:1010933404324>.
- [77] J. Mathew, M. Luo, C.K. Pang, Regression kernel for prognostics with support vector machines, in: 2017 22nd IEEE International Conference on Emerging Technologies and Factory Automation (ETFA), 2017, pp. 1–5, iSSN: 1946–0759. doi:10.1109/ETFA.2017.8247740..
- [78] I. Amihai, M. Chioua, R. Gitzel, A.M. Kotriwala, D. Pareschi, G. Sosale, S. Subbiah, Modeling Machine Health Using Gated Recurrent Units with Entity Embeddings and K-Means Clustering, in: 2018 IEEE 16th International Conference on Industrial Informatics (INDIN) iSSN: 2378–363X, 2018, pp. 212–217, <https://doi.org/10.1109/INDIN.2018.8472065>.
- [79] S. Pourarian, J. Wen, X. Li, D.A. Veronica, X. Zhou, R. Liu, Tools for Evaluating Fault Detection and Diagnostic Methods for Dual Duct Double Fan Systems, ASHRAE/IBPSA-USA Building Simulation Conference Last Modified: 2017-02-19T20:02-05:00..
- [80] S. Pourarian, J. Wen, D. Veronica, A. Pertzborn, X. Zhou, R. Liu, A tool for evaluating fault detection and diagnostic methods for fan coil units, *Energy Build.* 136 (2017) 151–160, <https://doi.org/10.1016/j.enbuild.2016.12.018>.
- [81] An expert rule set for fault detection in air-handling units/ Discussion - ProQuest (2001)..
- [82] H. Wang, Y. Chen, C.W.H. Chan, J. Qin, J. Wang, Online model-based fault detection and diagnosis strategy for VAV air handling units, *Energy Build.* 55 (2012) 252–263, <https://doi.org/10.1016/j.enbuild.2012.08.016>.
- [83] J. Trojanová, J. Vass, K. Macek, J. Rojiček, P. Stluka, Fault Diagnosis of Air Handling Units, *IFAC Proceedings Volumes* 42 (8) (2009) 366–371, <https://doi.org/10.3182/20090630-4-ES-2003.00061>.
- [84] K. Bruton, D. Coakley, P. Rafferty, D.O. Cusack, M.M. Keane, D.T.J. O'Sullivan, Comparative analysis of the AHU InFO fault detection and diagnostic expert tool for AHUs with APAR, *Energ. Effi.* 8 (2) (2015) 299–322, <https://doi.org/10.1007/s12053-014-9289-z>.
- [85] N.M. Ferretti, M.A. Galler, S.T. Bushby, D. Choinière, Evaluating the performance of Diagnostic Agent for Building Operation (DABO) and HVAC-Cx tools using the Virtual Cybernetic Building Testbed, *Sci. Technol. Built Environ.* 21(8) (2015) 1154–1164, publisher: Taylor & Francis \_eprint: doi: 10.1080/23744731.2015.1077670..
- [86] H. Hassanpour, P. Mhaskar, J.M. House, T.I. Salsbury, A hybrid modeling approach integrating first-principles knowledge with statistical methods for fault detection in HVAC systems, *Comput. Chem. Eng.* 142 (2020), <https://doi.org/10.1016/j.compchemeng.2020.107022> 107022.
- [87] K. Yan, J. Huang, W. Shen, Z. Ji, Unsupervised learning for fault detection and diagnosis of air handling units, *Energy Build.* 210 (2020), <https://doi.org/10.1016/j.enbuild.2019.109689> 109689.
- [88] G. Niu, B.-S. Yang, M. Pecht, Development of an optimized condition-based maintenance system by data fusion and reliability-centered maintenance, *Reliab. Eng. Syst. Saf.* 95 (7) (2010) 786–796, <https://doi.org/10.1016/j.res.2010.02.016>.
- [89] D. Bansal, D.J. Evans, B. Jones, A real-time predictive maintenance system for machine systems, *Int. J. Mach. Tools Manuf.* 44 (7) (2004) 759–766, <https://doi.org/10.1016/j.ijmactools.2004.02.004>.
- [90] P. Teicholz, *BIM for Facility Managers*, John Wiley & Sons (2013), google-Books-ID: wHQDghScf2YC.
- [91] COBie Means and Methods - WBDG - Whole Building Design Guide (2022). URL: <https://www.wbdg.org/bim/cobie/means-methods..>
- [92] M.A. Hassanain, T.M. Froese, D.J. Vanier, Development of a maintenance management model based on IAI standards, *Artif. Intell. Eng.* 15 (2) (2001) 177–193, [https://doi.org/10.1016/S0954-1810\(01\)00015-2](https://doi.org/10.1016/S0954-1810(01)00015-2).
- [93] What is COBie? (2022). URL: <https://www.thenbs.com/knowledge/what-is-cobie..>
- [94] Regio Midi manual (2013)..
- [95] BACnet – The New Standard Protocol (2022). URL: <http://www.bacnet.org/Bibliography/EC-9-97/EC-9-97.html..>
- [96] Organization of information about construction works – Information management using building information modelling – Part 1: Concepts and Principles (2018)..
- [97] BS 1192-4:2014 Collaborative production of information Part 4: Fulfilling employers information exchange requirements using COBie – Code of practice. (2014)..
- [98] Industry Foundation Classes (IFC) (2021). URL: <https://technical.buildingsmart.org/standards/ifc/..>
- [99] GraphDB Downloads and Resources (2021). URL: <https://graphdb.ontotext.com/..>
- [100] ENS-portalen Laugstol (2021). URL: <https://www.laugstol.no/energiservice/produkter/ens-portalen/..>
- [101] karelz, WebClient Class (System.Net) (2022). URL: <https://docs.microsoft.com/en-us/dotnet/api/system.net.webclient..>
- [102] J. Brownlee, How to Use StandardScaler and MinMaxScaler Transforms in Python (Jun. 2020). URL: <https://machinelearningmastery.com/standardscaler-and-minmaxscaler-transforms-in-python/..>
- [103] Institut Teknologi Sepuluh Nopember, A. Megantara, T. Ahmad, Institut Teknologi Sepuluh Nopember, ANOVA-SVM for Selecting Subset Features in Encrypted Internet Traffic Classification, *Int. J. Intell. Eng. Syst.* 14(2) (2021) 536–546. doi:10.22266/ijies2021.0430.48..
- [104] SVM-Anova: SVM with univariate feature selection (2021). URL: [https://scikit-learn/stable/auto\\_examples/svm/plot\\_svm\\_anova.html..](https://scikit-learn/stable/auto_examples/svm/plot_svm_anova.html..)
- [105] J. Schein, S.T. Bushby, N.S. Castro, J.M. House, A rule-based fault detection method for air handling units, *Energy Build.* 38 (12) (2006) 1485–1492, <https://doi.org/10.1016/j.enbuild.2006.04.014>.
- [106] Introduction and overview of the haystack software module for niagara-based systems (2013). URL: <https://project-haystack.org/file/7/NHaystack-Whitepaper.pdf..>
- [107] B. Balaji, A. Bhattacharya, G. Fierro, J. Gao, J. Gluck, D. Hong, A. Johansen, J. Koh, J. Ploennigs, Y. Agarwal, M. Berges, D. Culler, R. Gupta, M.B. Kjærsgaard, M. Srivastava, K. Whitehouse, Brick: Towards a unified metadata schema for buildings, in: Proceedings of the 3rd ACM International Conference on Systems for Energy-Efficient Built Environments, BuildSys '16, Association for Computing Machinery, New York, NY, USA, 2016, pp. 41–50, <https://doi.org/10.1145/2993422.2993577>.
- [108] A. Ajpas, A Feature Selection Based on One-Way-Anova for Microarray Data Classification, *AJPAS J.* 3 (2016) 1–6.
- [109] Multiclass Classification Metrics Reference (2021). URL: <https://www.coursera.org..>
- [110] R. Agarwal, D.G. Fernandez, T. Elsah, A. Gyrard, J. Lanza, L. Sanchez, N. Georgantas, V. Issarny, Unified IoT ontology to enable interoperability and federation of testbeds, in: 2016 IEEE 3rd World Forum on Internet of Things (WF-IoT), 2016, pp. 70–75, <https://doi.org/10.1109/WF-IoT.2016.7845470>.