



UNIVERSITY OF AGDER

Securing Assets with RFID

by

Santhakumar Chanrasekaram

and

Mats Oustad

Master Thesis in

Information and Communication Technology

University of Agder

Grimstad, May 23, 2008

ABSTRACT

Loss of property is something every company has had to deal with at some point, without proper securing this is a problem that is very hard to get control of. RFID has been available for decades but it has been a technology which has been dormant without very much development. In the last years the interest has grown and new ideas to use it has surfaced.

This thesis is set out to present a comprehensive solution proposal for a RFID asset management system. A case will be presented which will be a scarlet thread throughout the paper. We cover areas like RFID technology and standards, tags, readers, infrastructures, security issues and health risks.

The solution consists of general guidelines for setting up a RFID system. We present a system design showing the flow of data related to the case scenario, containing both hardware and software layers, spanning from the sensors to the frontend application. Each part of the case is given its own proposal but they are all woven together in the same infrastructure. We also present concept for the frontend application in form of a web portal.

The solution we propose is viable solution which covers the problem statement and shows how the case scenario can be set into life. This solution proposal can easily be adapted to similar tasks.

PREFACE

This thesis is written as part of the Master's degree in Information and Communication Technology at the University of Agder. The work was done between January 2008 and June 2008. The problem was stated by IBS Security AS, who is a company working with securing of inventory in sectors like education and health care.

We would to give our thanks to Dag Ståle Torgersen and Alf Torgersen at IBS Security for providing us with the thesis and assisting us during with the help we needed. We would also like to thank RFID Lab for interesting and educational day learning about RFID in theory and practice. Finally we would like to thank our supervisor Magne Arild Haglund (University of Agder) for his support and guidance all through the process.

Grimstad, May 2008

Santhakumar Chanrasekaram

Mats Oustad

TABLE OF CONTENTS

- 1 Introduction..... 9
 - 1.1 Report outline..... 10
- 2 Problem description 11
 - 2.1 Background and presentation of problem area 11
 - 2.2 Sub problems..... 12
 - 2.3 Purpose..... 14
- 3 Background..... 15
 - 3.1 Electronic Product Code 15
 - 3.1.1 Pure Identity 16
 - 3.1.2 General Type 16
 - 3.1.3 EAN.UCC Types (GS1) 17
 - 3.2 RFID Technology 20
 - 3.2.1 Tag types..... 22
 - 3.2.2 Tag Classification 26
 - 3.2.3 RFID Frequencies 28
 - 3.2.4 RFID Readers..... 32
 - 3.2.5 Different Kinds of tag 34
 - 3.2.6 EPC Generation 2..... 36
 - 3.2.7 Reader Antenna..... 37
 - 3.3 Existing solutions 40
 - 3.3.1 Most common areas of use 40
 - 3.3.2 Companies with solutions 42
 - 3.3.3 RFID Manufacturers..... 44
 - 3.4 Health Risks Concerning RFID..... 47
- 4 The Case 49

- 4.1 Limitations 52
- 5 Solution proposals..... 53
 - 5.1 Check list..... 53
 - 5.1.1 Tags..... 53
 - 5.1.2 Readers..... 56
 - 5.1.3 Selecting antennas 57
 - 5.1.4 Selecting Transmission Lines 57
 - 5.2 System design..... 58
 - 5.3 Proposals and Possible solutions..... 61
 - 5.3.1 Entrances 61
 - 5.3.2 Storage..... 63
 - 5.3.3 Server room 64
 - 5.3.4 Archives 65
 - 5.3.5 Overview..... 66
 - 5.3.6 Advanced features..... 67
 - 5.4 Frontends 68
- 6 Discussion 75
- 7 Conclusion 79
- 8 Future work..... 81
- Bibliography..... 82
- Glossary & Abbreviations 85

LIST OF FIGURES

Figure 1: General Identifier (GID-96) bit distribution..... 16

Figure 2: Serial Global Trade Item Number..... 17

Figure 3: Serial Global Location Number 18

Figure 4: Global Returnable Asset Identifier 18

Figure 5: Global Individual Asset Identifier 19

Figure 6: Serial Shipping Container Code..... 19

Figure 7: RFID structure overview..... 20

Figure 8: An active RFID tag 23

Figure 9: Modern Handheld RFID Reader 32

Figure 10: Stationary RFID reader 33

Figure 11: UHF Circular polarized reader antenna from Alien Technology 37

Figure 12: Horizontal and vertical linearly polarized antennas 38

Figure 13: Wave pattern from a circular polarized antenna..... 39

Figure 14: Circular and linear polarized antenna patterns 39

Figure 15: Company X office building 49

Figure 16: System flow chart..... 50

Figure 17: System design..... 58

Figure 18: Entrance portal..... 61

Figure 19: Server room portal with directional antennas..... 64

Figure 20: Solution proposal for 1st floor where the server room is located..... 66

Figure 21: Frontend overview 68

Figure 22: Log in site for the web portal 69

Figure 23: Overview of the entire building status 70

Figure 24: Overview of the 3rd floor status 71

Figure 25: Inventory list 72

Figure 26: User list..... 73

Figure 27: Reader array..... 73

LIST OF TABLES

Table 1: Characteristics of tag types 25

Table 2: Characteristics of RFID Tag Classes 27

Table 3: Characteristics of various radiofrequency ranges..... 28

Table 4: Radio Frequency ranges in which RFID systems can operate 29

Table 5: Radio frequency bands used for RFID devices in various countries..... 30

Table 6: UHF bands allocated for RFID systems worldwide..... 31

Table 7: Comparison of some features of EPC Class 1 Gen 2 and Class 1 Gen 1 36

Table 8: Overview of the solution proposal..... 66

1 INTRODUCTION

Theft and loss of property is an age-old problem society and individuals never seem to conquer. At companies or organizations that have a lot of stock or inventory, it is especially difficult to keep track of things at all times. RFID technology comes in good hand. Use of this technology will only grow in the coming years.

This is a master thesis paper at University of Agder, done by two students studying Master degree in Information Communication Technology (ICT). This paper will give a comprehensive review on how to keep track of assets or secure inventory by the means of RFID. To narrow down the field of work, a case will be built and a thorough investigation of this case is given. The case will be built together with IBS Security AS, who is the problem owner and specializes in securing inventory.

To solve our problem we will collect data about RFID, Electronic Product Code and other subjects that may give us a better understanding about the technology, to solve the case. Then we will give a full review of the case. This review will include possible solutions for a system and take RFID technology, tags, readers, infrastructures and security issues into consideration, and also consider health risks.

1.1 REPORT OUTLINE

In the following chapter the problem description will be presented, we will give background information about the motivation for the thesis and present problems and sub problems we are going to solve.

Chapter three will contain background material about the RFID technology and standards, and present existing solution. We will also give a brief presentation about the leading manufacturers and what they have to offer of products. In this chapter the health risks concerning RFID are going to be displayed.

The case will be presented in chapter four; this will contain the guidelines and work as a scarlet thread for the following chapters in the thesis. We will also give some limitations to the thesis in this chapter, in order to make the end product more specific.

The fifth chapter will be the solutions and proposals to the problem areas given both in the case and the problems description. Here we go through the case area by area and propose the solutions which we find best based upon the background chapter. There will also be sub chapters containing system design and an example on a frontend web portal.

In chapter six we will discuss the results and findings, linking them back to the background and talk about the pros and cons of choosing the different technologies. Chapter seven will contain the conclusion here we will briefly recap the thesis and mention the most important parts of the thesis, in addition to proposing what can be done in the future.

2 PROBLEM DESCRIPTION

In this project we will give a thorough investigation of a case, built by students and the problem owner. It will give a comprehensive review on how to keep track of assets or secure inventory by the means of RFID.

There shall be given a full review of a case containing possible solutions for a system and take RFID technology, tags, readers, infrastructures and security issues in consideration, and also consider health risks. Another goal is to map RFID technology into existing solutions. The demonstrator of the software for handling registering of the inventory traffic may also be developed, but this goal is lower prioritized and optional.

2.1 BACKGROUND AND PRESENTATION OF PROBLEM AREA

Theft and loss of property is an age-old problem society and individuals never seem to conquer. At companies or organizations that have a lot of stock or inventory, it is especially difficult to keep track of things at all times. The need to find a good and reliable solution to keep track of and guard inventory from theft is ever present. Today this is often done by applying each item with some kind of mark. This could be stickers, etching a mark into the item or more subtle things that can only be seen by UV light. In this day and age of the digital world, these techniques have become obsolete and outdated.

IBS Security AS is the problem owner and they got over ten years experience in the securing of inventory business. They want to get a thorough analysis of how RFID can be utilized in an inventory tracking system, concerning both infrastructure and technology.

The infrastructure of such a system is crucial, because it needs to cover all exits and crucial checkpoint in the buildings that the system is installed. We need to investigate the different RFID technologies that are available and also look into the possibilities of customizing RFID chips and readers for IBS Security needs if necessary. Another part of the problem area will be to find a good solution to connect the reader infrastructure to a backend administration system.

2.2 SUB PROBLEMS

1. Structure a well defined case

The buildings and companies can have different sizes and structures. Therefore we need to narrow down the scope to get a deeper insight and a more concrete guideline on how to conduct our further research.

2. Which RFID technology to choose

There are different kinds of RFID technologies out there. When it comes to tags, we have passive and active tags, which are the main groups but their properties can vary. Different technologies have different strengths and weaknesses. Choosing the right tags, scanner and readers is very important to build a good infrastructure.

3. How to build a good infrastructure

Once we have gotten a deep insight in the RFID technology, the next step is to look how to solve the infrastructure issues. We need to find out the best places to position readers and how many of them are needed, so that we can give maximum coverage within the areas of interest. We will also have to find out how we can connect the readers into one big array of readers so they work together as one system.

4. Health and environmental issues

RFID tags and readers emit electromagnetic radiation. We need to take into consideration that such radiation can interfere with other equipment, which might be critical. And also try to keep this at a minimum because the possible health risks of this radiation are not fully charted.

5. Build a demonstrator

A demonstrator is needed to show that the infrastructure architecture actually works and not only works in theory. This part is low prioritized hence lack of time.

6. *Map existing solutions and prior work*

During the collection of data we need to look into existing solutions and work, to solve the case in best manner.

2.3 PURPOSE

Use of RFID technologies induce many technological possibilities that are more and more implemented in our lives. RFID is used by Norwegian postal service Posten for tracking packages, used in stores for prevent stealing and also used in AutoPass, but not so much used for securing inventory at middle or large companies and hospitals. Setting up a system with RFID technology to keep track of inventory for a company with large building with many entrances and exits could be really challenging. Infrastructure is therefore a very important part of the whole research and we will also take security issues into consideration. With this project we want to enlighten the process of putting a system together.

The research will point out weaknesses and strengths with RFID technologies and how we can put them together into a system. By this, we can achieve better security and less loss of things and materials and save the companies for lot of moneys. Stealing without anyone knowing will be very difficult.

During the thesis, we will gain insights into security issues regarding securing inventory, how to build a secure infrastructure with different RFID tags and readers and by that gain knowledge of different kinds of RFID technologies. The RFID technology is not a new technology but research on putting them together into an infrastructure, will be much appreciated.

3 BACKGROUND

In this chapter we will discuss the technologies, standards and previous known solutions that are essential to solve this thesis.

We will discuss electronic product code, which is industry standardization, and different types of them. RFID technology is a big part of this chapter, and we will take a closer look on tag types and classifications of them, frequencies they operate on, and RFID readers and readers' antennas.

We will also look into the different RFID solutions on the market today, in addition to listing some major producers and what kind of products they can offer.

Finally we will examine the possible health risk associated with deploying RFID into the workplace.

3.1 ELECTRONIC PRODUCT CODE

EPC or Electronic Product Code is industry standardization, developed by the EPCglobal organization. EPCglobal is a subscriber-driven cooperation between some of the world's biggest companies, such as Hewlett-Packard and Cisco. It was started by the organizations who were working on making standards for bar codes, GS1 and GS1 US. EPCglobal is a non-profit organization and its goal is to create worldwide standards for the RFID technology. ^[3]

Electronic Product Code is simply put a RFID tag with a unique number on it, which can be used to separate different product and/or assets. EPC was developed by researchers at MIT¹ and is regarded as the next generation bar code technology. ^[4]

¹ MIT, Massachusetts Institute of Technology

3.1.1 PURE IDENTITY

To achieve pure identity, the identifiers of an entity have to only be linked up to this single entity. If the identifiers are not unique pure identity cannot be achieved using that particular set of identifying numbers or name.

3.1.2 GENERAL TYPE

The inventors of EPC proposed three different sizes of EPC, 64-, 96- and 128-bit in addition to a header which is used to for example give information about how many bits the following EPC contains. The most common type of EPC in use today is the 96-bit version. 96-bit EPC is enough to supply 268 million companies with a unique series. Each company can then have 16 million classes and 68 billion serial numbers in each class, if one use the General Identifier specification. This is the general tag standard specification from EPCglobal. [5]

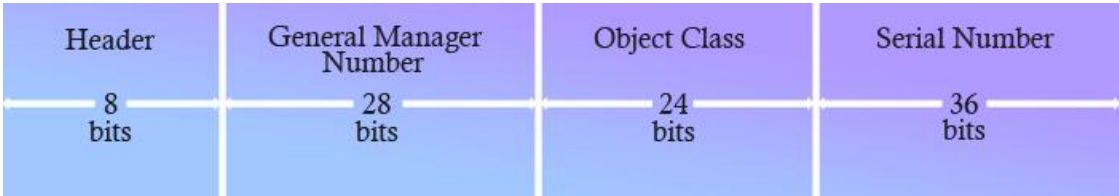

Figure 1: General Identifier (GID-96) bit distribution

The first two fields of Figure 1 are assigned by EPCglobal the last two is assigned by the company using the General Manager Number series.

3.1.3 EAN.UCC TYPES (GS1)

There are also several EPC code standards relating to the EAN.UCC² barcodes, which allows direct embedding of these barcode standards onto EPC tags. EAN.UCC is today know as GS1 and as earlier mentioned this is the organization behind EPCglobal, so it comes naturally that they transfer their widely used barcode numbering standards over to the new technology.

3.1.3.1 SERIAL GLOBAL TRADE ITEM NUMBER (SGTIN)

GTIN is an identifier for trade items, in for example retail stores or for a collector to keep track of what is in the collection. The GTIN term is used as a container to describe many different data structures that are used to identify trade items in the GS1 system. The problem with implementing the GTIN with EPC is that it does not support the EPC pure identity concept, since it doesn't provide unique identification of a single physical object. GTIN only identifies classes of objects. In order to solve this SGTIN was developed. SGTIN adds a serial number to the old GTIN number. This makes it possible to achieve pure identity.^[6]

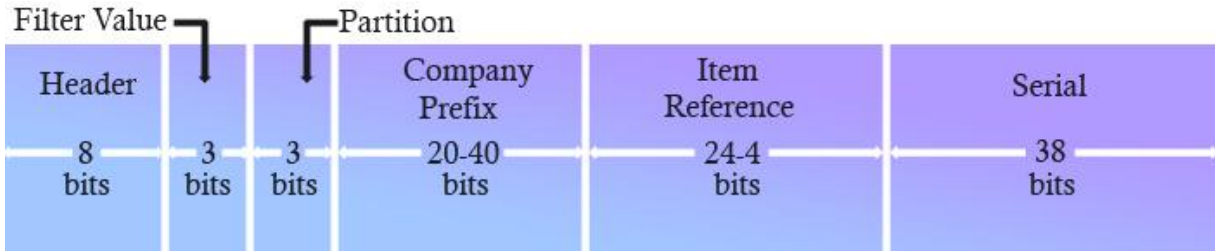

Figure 2: Serial Global Trade Item Number

SGTIN also comes in a 198 bites version, where the serial is 140 bits long.

² European Article Numbering-Uniform Code Council

3.1.3.2 SERIAL GLOBAL LOCATION NUMBER

Global Location Number (GLN) has just like the GTIN had a serialized successor with the transaction to RFID. The main use for this type of EPC code is to mark a physical location or entity, in a geographic context. It can for example be a warehouse, or a single office inside an office building.

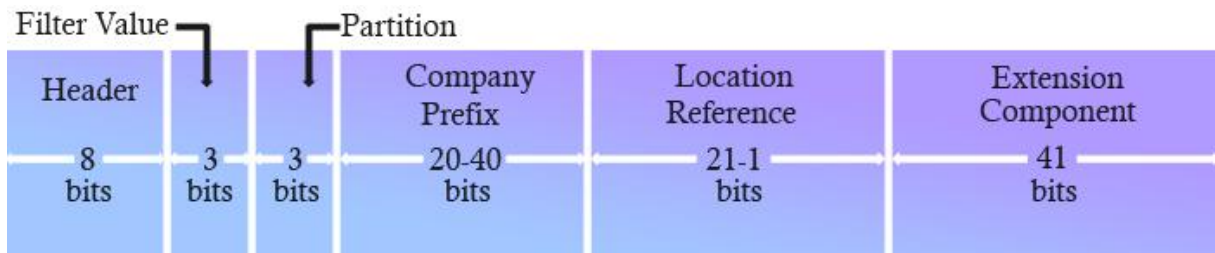

Figure 3: Serial Global Location Number

In addition to the basic 96 bit version, there is also a standard for a 195 bit SGLN EPC. It has the same bit pattern as SGLN-96, except for the Extension Component which is 140 bits long instead of 41. [7]

3.1.3.3 GLOBAL RETURNABLE ASSET IDENTIFIER

The GRAI format were made to mark individual object with a unique ID and therefore it was no reason to do any changes when adapting it to the EPC standard as it was already true to the pure identity concept. This GRAI-96 and SGTIN-96 has the same bit distribution, but slightly different naming.

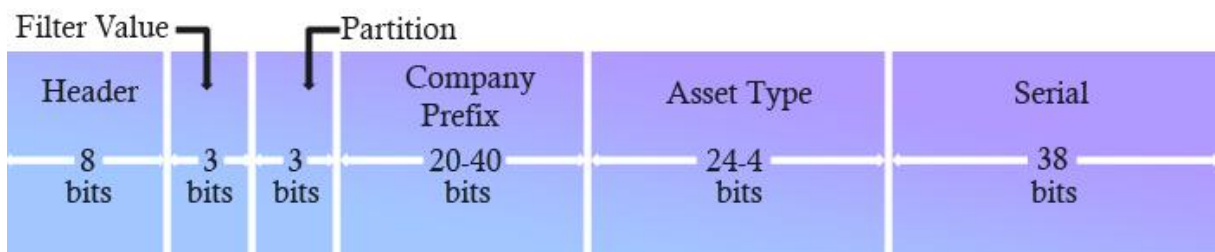

Figure 4: Global Returnable Asset Identifier

There is also a 170 bit standard for GRAI, in this standard it is the serial number from the figure above which is expanded from 38 to 112 bits. [8]

3.1.3.4 GLOBAL INDIVIDUAL ASSET IDENTIFIER

The GIAI like the GRAI was already made to uniquely identify a single object. Thus there was no need to add new fields in order to achieve pure identity.

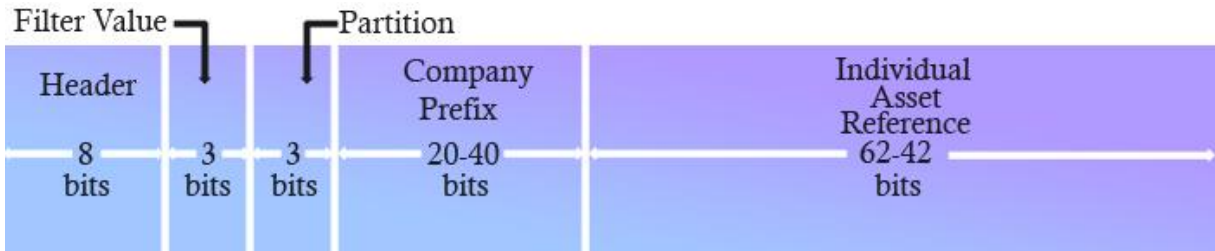

Figure 5: Global Individual Asset Identifier

GIAI-202 is the other standard it extends the Individual Asset Reference to 168-126 bits. [8]

3.1.3.5 SERIAL SHIPPING CONTAINER CODE

SSCC is EPC code scheme that are used to mark and identify logistical entities. SSCC were specified to identify a single entity, in other words it has pure identity and can be directly transformed into EPC from the EAN.UCC barcodes. [9]

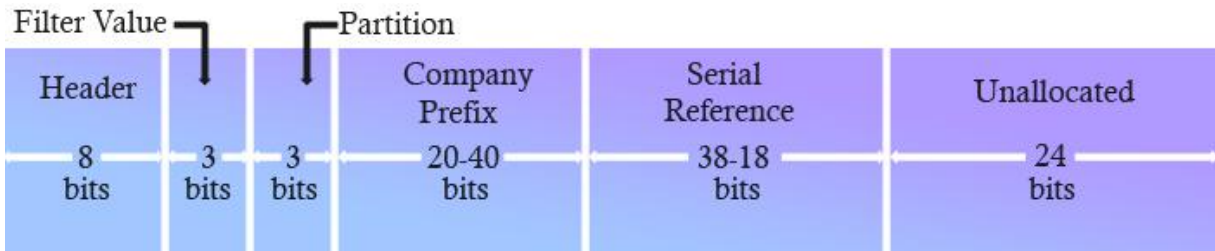

Figure 6: Serial Shipping Container Code

3.2 RFID TECHNOLOGY

Radio frequency identification is a technology that creates the possibility of communication between two entities, a tag and a reader. This technology can be roughly divided into two main parts, passive and active. A combination of these two types is called semi passive or semi active tag. The terms passive and active reflects on how the tags are constructed and how they work.

Radio Frequency Identification system consists of two main parts, transmitter and receiver. The labels, access cards and even passports in some countries, have RFID transponders integrated. These transponders are called “tags”.

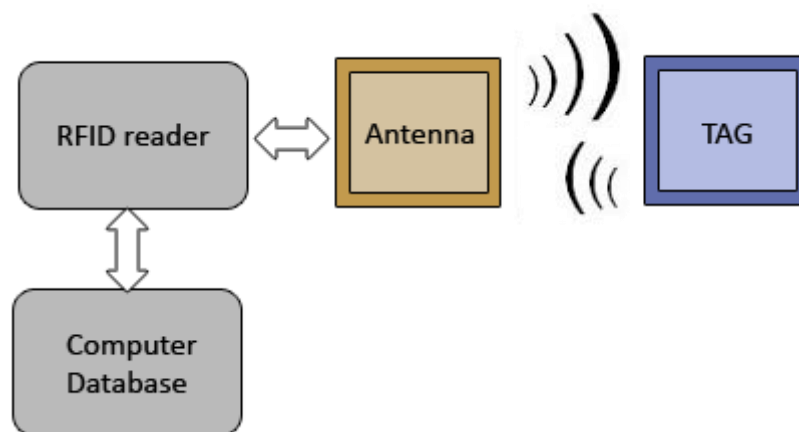

Figure 7: RFID structure overview

Each tag contains data that are programmed in it and the information can be read by readers with a Radio Frequency link. The size of a tag can vary; it can be miniature like thicker paper sheets or big like a remote controller. The simplest tags only have antenna and diode and only reflect signals coming from a transmitter. In supermarkets and stores these are used to secure goods from theft. When a person steals a product and comes near the transmitter at the entrance, the signal is reflected and alarm triggered. This wouldn't happen if the seller had scanned this product, because then a kill command would have been sent to the tag and this would have electrically destroyed the tag, so it will not trigger an alarm.

Compared to other widely used labeling technologies, like bar codes, RFID has more advantages. RFID tags can have much more data than bar codes; can easily contain 512 bits of data and more. The data of RFID tags can be rewritten many times. So it is easier to track shipping, to assign properties, or to give additional security access to personal of the office. ^[10]

Another advantage of using RFID tags is that they do not need to be in “line of sight” to be read and there is possible to read multiple tags within the range.

3.2.1 TAG TYPES

The tag type and the frequency at which the tag operates are the two major characteristics that determine the performance and use of a tag. Tag types are determined by two factors:

- Can the tag initiate the communication?
- Does the tag have its own power source?

Based on different combinations of these questions, there are three types of tags; passive, active and semi-passive. ^[11]

3.2.1.1 PASSIVE TAGS

A passive tag is a very small and cheap piece of equipment and costs between 10 cents and a few dollars. They do not have their own power source; this is why they are called passive. Passive tags are powered from electromagnetic field generated by RFID reader antenna. These tiny amounts of energy temporarily energizes circuits in the tag. This induced power is just enough for the tag to reply to the request sent by the inducer. The range of a passive tag is very limited and can be read only at very short distances, typically a few feet at most although some modern tags can operate up to 9 meter if care is taken with tag orientation. Passive tags usually operate at low, high and ultrahigh frequency band. The higher the frequency the more expensive manufacturing of the tags will be, because of processing with more precise electronics, but they can support higher data stream. ^[10]

Passive tags are most commonly used because they are cheap, they can last indefinitely long as there is no need for power supply, and they are small sized which allows them to easily integrate with almost every environment starting with wrists, necklaces, cards, stickers. They are generally also resistant to corrosion and physical damage. ^[10]

3.2.1.2 ACTIVE TAGS

The more expensive and physically larger active tags, work a bit different from the passive tags. The active tags have their own power source, mostly in the form of a battery or external power source. Batteries can sometimes be replaceable or the unit will be replaced after certain time, normally between 1 year and 7 years. With own power source the active tag can power its own antenna and circuits, thus gives the opportunity to have a more complicated communication with the reader. In example it can be initiator of communication not just the recipient. The range of the active tag is far better than the passive tags; active transponders can communicate in very long ranges up to several hundred kilometers. This higher level of complexity also gives a lower fault tolerance since the tag cannot operate if the power source is malfunctioning.

Main disadvantages of active tags may be relatively big size and production price compared to passive ones. ^[10]



Figure 8: An active RFID tag

3.2.1.3 SEMI-PASSIVE TAGS

Semi-passive tags are more similar to passive transponders than active ones. The tags have their own power source such as a battery but do not initiate communication. In other words, the readers' signal wakes up the passive tag.

A semi-passive tag uses the battery to run the circuitry and uses the power from the incoming signal to prepare the response. All received power can be used for transmitting back a signal which is stronger than passive transducer. This allows increasing communication distance with a quite cheap solution. ^[10]

3.2.1.4 CHARACTERISTICS OF TAG TYPES

The characteristics of passive, semi-passive and active tags are summed up in the table below. ^[11]

Tag type/ Tag characteristic	Passive	Semi-passive	Active
Power source	No power of its own; receives power from the reader's signal	Has its own power source(battery)	Has its own power source(battery)
Communication	Communication must be initiated by the reader	Communication must be initiated by the reader	Can respond to the reader's signal and can also initiate the communication
Size	Small Could be as small as (0.15mm x 0.15mm) x 7.5 mm	Medium Larger than passive	Largest Typically (1.5 x 3) x 0.5 inch ³ Smallest: size of a coin
Read range	Short 2mm and up to few meters depending on the operating frequency	Up to 100 m	Large (up to 1 km is possible); some limitations apply, resulting from standards and regulations
Memory design	Read only(RO), write once/read many (WORM), read/write (RW)	Read only(RO), write once/read many (WORM), read/write (RW)	Read only(RO), write once/read many (WORM), read/write (RW)
Memory capacity	Mostly up to 128 bits, but some tags can have memory up to 64 KB	—	Up to 8 MB
Cost	Inexpensive	Intermediate	Expensive
Lifespan	No need to replace a battery; has longer life time	Shorter life time than a passive tag, because of the battery.	Finite, but long enough battery lifetime. Realistically: as long as 10 years.
Frequency ranges	Low frequency (LF), high frequency (HF), ultrahigh frequency (UHF)	Low frequency (LF), high frequency (HF), ultrahigh frequency (UHF)	Ultrahigh frequency (UHF), microwave frequency

Table 1: Characteristics of tag types

3.2.2 TAG CLASSIFICATION

Tags containing electronic product codes (EPCs) are called EPC tags. The complexity of such tag varies depending on its functionality; how it communicates and whether or not it has a power source of its own.

The increased functionality and therefore complexity of tags results in increased cost because tags with advanced functions require more expensive microchips and their own power source. Most business sectors required only the simplest and therefore lowest cost tags. To accommodate varying levels of complexity, MIT's Auto ID Center proposed six tag classes, Generation 1 tags, presented in the table below. The table also contains characteristics of these classes. ^[11]

Tag Characteristic / Tag Class	Type	Memory	Communication	More Properties
Class 0	Passive	Read-only	Does not initiate communication	The EPC number is encoded onto the tag during manufacture and can be read by a reader
Class 0+	Passive	Same as class 0, but you can write once	Does not initiate communication	—
Class 1	Passive	Read many times and write once	Does not initiate communication	EPC number is not encoded by the manufacturer but can be encoded later in the field
Class 2	Passive	Read many times and write once	Does not initiate communication	Encryption
Class 3	Semi-passive	Read and write many times	Does not initiate communication	Class 2 capabilities plus extra such as integrated sensors

Class 4	Active	Read and write many times	Can initiate communication; power their own communication; tag-to-tag communication possible	Class 3 capabilities plus extras
Class 5	Active	Read and write many times	Can initiate communication; power their own communication; tag-to-tag communication possible	Class 4 capabilities plus extras

Table 2: Characteristics of RFID Tag Classes

3.2.3 RFID FREQUENCIES

Tags use radio waves to respond to readers and these waves are basically the electromagnetic waves covering part of the electromagnetic spectrum of frequencies called radio frequency spectrum. Other radio services that use radio frequency spectrum are radio, television, mobile radio services (police, security services and industry) and mobile telephones, just to mention some. Therefore it is important that these services are not disrupted or impaired by the RFID and significantly restricts the suitable operating frequency ranges available for RFID systems.

RFID systems use many different frequencies in the radio frequency spectrum, but there are four most commonly uses radio frequency ranges: low frequency, high frequency, ultrahigh frequency, and microwave frequencies. ^[11]

Frequency Band	Advantages	Disadvantages	Typical RFID Applications
Low frequency (LF)	Can work well around water and metal; accepted worldwide	Short read range and slow read speed	Animal identification, product authorization, close read of items with high water content
High frequency (HF)	Better accuracy and read speed, easier to read at a distance, can carry more information	Requires higher power	Building access control, airline baggage, libraries
Ultrahigh frequency (UHF)	Faster read speed, easier to read at a distance, can carry more information	Does not work well near water or metals	Parking lot access, automated toll collection, supply chain
Microwave frequency	Faster read speed	Does not work well near water or metals	Vehicle identification, automated toll collection, supply chain

Table 3: Characteristics of various radiofrequency ranges

The table below shows the radio frequency ranges that are of interest to RFID systems, along with the ISM frequencies. Industrial, scientific and medical (ISM) frequencies, originally reserved for noncommercial uses in industrial, scientific and medical fields, are generally used for RFID systems.

Name	Frequency Range	Wavelength Range	ISM Frequencies	Read Range for Passive Tags
Low frequency (LF)	30 – 300 kHz	10km – 1 km	< 135 kHz	< 50 cm
High frequency (HF)	3 – 30 MHz	100 m – 10 m	6.78 MHz, 8.11 MHz, 13.56 MHz, 27.12 MHz	< 3 m
Ultrahigh frequency (UHF)	300 MHz – 3 GHz	1 m – 10 cm	433 MHz, 869 MHz, 915 MHz	< 9 m
Microwave frequency	1 GHz – 300 GHz	30 cm – 1 mm	2.44 GHz, 5.80 GHz	> 10m

Table 4: Radio Frequency ranges in which RFID systems can operate

It is important to note that the read range performance improves with the increase in the frequency. However, the read range also depends on other factors such as the maximum power of the antenna is allowed to transmit, the communication technique being used, tag type, regulated maximum radiated power and antenna size. ^[11]

RFID system operate in four main ranges of the radio frequency spectrum; LF, HF, UHF and microwave. The choice of frequency does not affect the underlying physics of how the system components will operate, but it does affect the systems performance in areas such as speed, range and accuracy. ^[11]

3.2.3.1 COUNTRY REGULATED FREQUENCIES

We have three radio frequency regulatory regions in the world.

- Region 1 – includes Europe, Africa, the Middle East and the former Soviet Union
- Region 2 – includes North and South America
- Region 3 – Asia and Australia

RFID devices that work in one region will not work in another region, because they usually operate on different frequencies. Each country in these regions manages its frequency allocations within the guidelines. Table below shows the radio frequency ranges used for the RFID device in various countries. ^[11]

Country	LF	HF	UHF	Microwave
United States	125, 134 KHz	13.56 MHz	902 – 928 MHz	2.40 – 2.48 GHz 5.72 – 5.85 GHz
Europe	125, 134 KHz	13.56 MHz	865 – 868 MHz	2.45 GHz
Norway	125, 134 KHz	13.56 MHz	865.6 – 867.6 MHz	2.446 – 2.454 GHz
China	125, 134 KHz	13.56 MHz	N/A	N/A
India	125, 134 KHz	N/A	865 – 867 MHz	2.40 GHz
Japan	125, 134 KHz	13.56 MHz	950 – 956 MHz	2.45 GHz
Singapore	125, 134 KHz	13.56 MHz	923 – 925 MHz	2.45 GHz

Table 5: Radio frequency bands used for RFID devices in various countries

For different parts of the world, the regulatory bodies have chosen different ranges for RFID within the UHF band. Table below shows UHF bands allocated for RFID systems worldwide. The permitted radiated power is expressed in units of watts, but in different quantities. United States present radiated power by EIRP (Equivalent Isotropically Radiated Power) and Europe tends to use ERP (Effective Radiated Power).

Area	UHF Frequency Band Allocated to RFID Systems	Maximum Power Emission
United States	902 – 928 MHz	4 W (EIRP)
Australia	918 – 926 MHz	1 W (ERP)
Europe	865 – 868 MHz	2 W (ERP)
Norway	865.6 – 867.6 MHz	2 W (ERP)
Hong Kong	865 – 868 MHz 920 – 925 MHz	2 W (ERP) 4 W (EIRP)
India	865 – 867 MHz	4 W (EIRP)
Japan	950 – 956 MHz	4 W (EIRP)
Singapore	923 – 925 MHz	2 W (ERP)

Table 6: UHF bands allocated for RFID systems worldwide

3.2.4 RFID READERS

The main differences in RFID readers are the frequency they operate on. Of course it depends if they operate on different bands, like HF and UHF, but also as mentioned in chapter 3.2.3 the different bands might have other frequencies in one country than another. Therefore the choice of reader must be coherent with the choice of tags and vice versa. The readers must also in most countries be below a certain limit of power it can emit. For example the INTERMEC IP4 Portable RFID Reader (UHF) was not approved by Norwegian Post and Telecommunications Authority, because it emitted too much radiation on several frequencies and Intermec had to withdraw it from the market. ^[22]

RFID readers can be classified into two primary categories, smart readers and simple readers. The simple readers are made only to collect tag data and pass it on, thus all decision making is moved further up the “food-chain”. The smart readers on the other hand can offer a lot more when it comes to handling the tag data. These extra features make them able to evaluate the data and they can also make decisions to trigger actions if errors occur. Moving some of the decision making to the reader, removes much of the server communication delay.

3.2.4.1 HANDHELD READERS

Handheld readers are small and easy to carry, designed to be used when walking around checking for tags. The newer types come with a mobile version of Windows and have Wi-Fi access, so it at any time can be synchronized with the central server.



Figure 9: Modern Handheld RFID Reader ^[23]

3.2.4.2 STATIONARY READERS

Stationary readers are used to collect information from one or more antennas placed out, and connected to the reader. The different readers can handle anything from 1 to 8 antennas. They come both in wired connections and in Wi-Fi versions.



Figure 10: Stationary RFID reader^[24]

3.2.5 DIFFERENT KINDS OF TAG

Tags are produced in various shapes and sizes and are available in various media configurations. The selection of the tag depends usually on the application requirements. In following sub chapters we will discuss some of these types.

3.2.5.1 INLAY

An inlay is the simplest form of tag. It is a combination of antenna, chip and the material it is mounted on. An inlay needs to be labeled or packaged before use. ^[11]

3.2.5.2 INSERT

An insert is an inlay inserted between a label in the front and adhesive in the back. Inserts are available in different sizes depending on the use of this tag. Thick inserts can be used in harsh environments, paper-thin inserts in a pressure-sensitive environment e.g. track parcels and postage stamp sized inserts in movie covers. ^[11]

3.2.5.3 SMART LABELS

A smart label is a barcode label that has an embedded RFID tag inside it. Human readable and useful information, such as sender's address, destination address and product information can be printed on the labels face. A smart label consists of the components inlay, label face stock for printing of human readable information, adhesive and release liner.

Smart labels are designed to withstand a number of hazards such as extreme temperature, chemicals, moisture and exposure to ultraviolet radiation. ^[11]

3.2.5.4 RFID-ENABLED TICKETS

A RFID-enabled ticket is inserted into paper or plastic envelop that is directly attached to the items that need to be identified. The material used for envelops should be ultraviolet resistant, which means transparent to UHF waves. Polyester and polyethylene are such materials that offer low distortion for UHF waves. ^[11]

3.2.5.5 TIE-ON TAGS

A tie-on tag is basically a RFID-enabled ticket that is attached with a tie-on. Tie-on tags are usually used on non-conveyable items. If the tie-on material is made out of a conductive material, it may positively or negatively affect the tag performance. ^[11]

3.2.6 EPC GENERATION 2

EPCglobal through its research wing, Auto ID-Labs, has defined specifications for different classes of EPC tags. Generation 1 class 0 and class 1 tags are being replaced by class 1 generation 2 UHF tags or just gen 2. Class 0 EPC tags had a factory-programmed 96-bit code whereas class 1 allows for user-programmable codes. The gen 2 interface addresses a number of problems that had been experienced with class 0 and class 1 tags. It was adopted with minor modifications as ISO 18000-6C in 2006. ^[25]

Class 1 gen 2 RFID is faster, with a more flexible read and writes speed. Provides four different communication speeds to provide more diversity for different operating environments. It also offers higher reliability in tag counting, more robust performance of readers in close proximity and enhanced security. Gen 2 systems can read to over thousand tags per second in applications which are well insulated from radiofrequency noise, in noisy conditions hundred or more tags per second with high reliability. The read speed of Gen 2 is expected to be up to twice as fast as Gen 1. ^[26]

FEATURE	CLASS 1 GEN 2	CLASS 1 GEN 1
Read speed (Reads per sec running sort protocol; field performance highly dependent on application)	<ul style="list-style-type: none"> ◦ Up to 880 (US FCC) ◦ Up to 450 (EU ETSI) ◦ Speed adaptable to RF noise in environment 	<ul style="list-style-type: none"> ◦ Up to 230 (US FCC) ◦ Up to 115 (EU ETSI)
Write speed (for 96-bit EPC)	<ul style="list-style-type: none"> ◦ 5 tags per sec minimum ◦ Rewriteable many times 	<ul style="list-style-type: none"> ◦ 3 tags per second ◦ Rewriteable many times
Security	<ul style="list-style-type: none"> ◦ 32-bit lock and kill passwords ◦ Option for “handle”-based communication 	<ul style="list-style-type: none"> ◦ 8-bit kill password, with lockout after incorrect queries
Extensibility	<ul style="list-style-type: none"> ◦ Up to 512 bit item ID ◦ Unlimited user memory ◦ Anticipates Class 2 & 3 systems 	<ul style="list-style-type: none"> ◦ Up to 96 bit item ID
Tag data verification	<ul style="list-style-type: none"> ◦ 16-bit CRC for reads and writes 	<ul style="list-style-type: none"> ◦ 16-bit CRC for reads

Table 7: Comparison of some features of EPC Class 1 Gen 2 and Class 1 Gen 1

3.2.7 READER ANTENNA

An antenna is a device that is being used to receive or radiate electromagnetic waves. A reader communicates to a tag through the reader's antenna, a separate device that is physically attached to a reader at one of its antenna ports, by the means of a cable. A single reader can support up to eight antennas.

An antenna broadcasts the reader transmitter's radiofrequency signal into its surroundings and receives tag responses on the reader's behalf. Therefore, proper positioning of the antennas, not the readers, is essential for good read accuracy. In addition, some stationary readers might have in-built antennas. As a result, in this case, positioning the antennas for a reader is equivalent to positioning the reader itself. In general, RFID reader antennas are shaped like rectangular or square boxes.^[27]

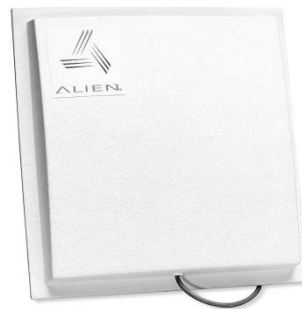

Figure 11: UHF Circular polarized reader antenna from Alien Technology

An antenna emits power measured in either effective radiated power (ERP) units in Europe or in equivalent isotropic radiated power (EIRP) units in the United States. ERP and EIRP are not the same but are related by the relation $EIRP = 1.64 ERP$. The maximum possible value of antenna power is limited by national and international regulations. To use an antenna with higher power than the allowable limit, we must obtain explicit permission from the appropriate regulatory body.^[27]

The main antenna types in UHF, based on polarization, are linear polarized antennas and circular polarized antennas.

3.2.7.1 LINEARLY POLARIZED ANTENNA

If the electromagnetic wave variations or vibrations are such that the electric field vector stays parallel to a line in space as the wave travels, the wave is linearly polarized, and the antenna that transmits such wave a linearly polarized antenna. We have two types of linearly polarization, horizontal and vertical polarization. ^[11]

A linearly polarized antenna emits a narrow radiation beam that increases the read range of a tag. These types of antennas are useful for applications in which the tag orientation are fixed and known. Dipole antennas are linearly polarized. ^[28]

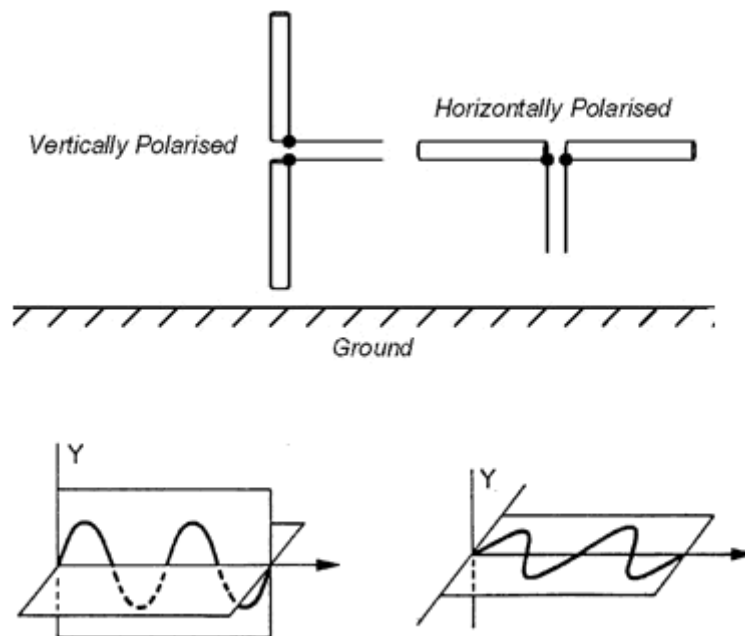

Figure 12: Horizontal and vertical linearly polarized antennas

3.2.7.2 CIRCULARLY POLARIZED ANTENNA

A circularly polarized antenna emits circularly polarized waves, which mean that the electric vector rotates in a circle as the electromagnetic wave travels. A circularly polarized signal contains horizontal and vertical components and therefore a circularly polarized reader antenna is largely unaffected by the tag orientation. Since circularly polarized antennas can read both vertical and horizontal polarization, they are preferred in applications in which the tag orientation is unknown or unpredictable. ^[11]

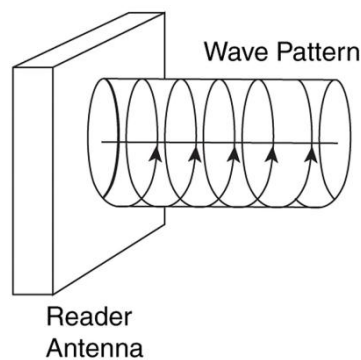

Figure 13: Wave pattern from a circular polarized antenna

A circular polarized antenna has a wider radiation beam and hence reads tags in a wider area compared to a linear polarized antenna. This antenna is preferred for an RFID system that uses high UHF or microwave frequencies in an operating environment where there is a high degree of radio frequency reflectance. ^[27]

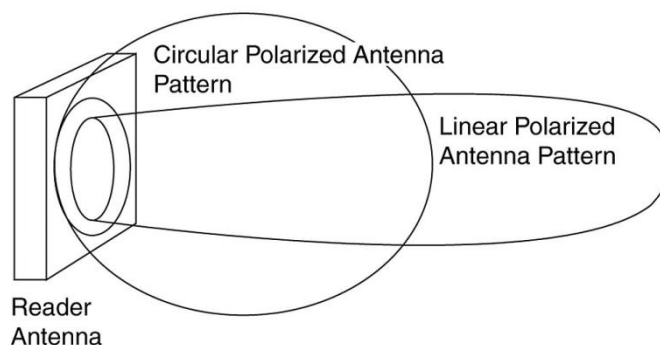

Figure 14: Circular and linear polarized antenna patterns

3.3 EXCISTING SOLUTIONS

On the market today there are some companies delivering end-to-end solution for marking and tracking inventory with RFID. Though there are not many of these solutions which are available on the Norwegian/Scandinavian market today, most of the companies are targeting the US or the Chinese market.

3.3.1 MOST COMMON AREAS OF USE

3.3.1.1 PHARMACEUTICS/MEDICAL

At Pharmacies they use RFID to tag drugs. This makes it easier to know what is in stock and also adds a layer of security. The pharmacist can scan the container and get an ID of what it contains. The extra layer of security can help prevent giving customers the wrong medicine. In hospital and other medical facilities they have brought the RFID technology to more places than just the drug storage. They can for instance tag glasses of blood samples, with info about blood type, who is the blood giver etc. This makes it fast and simple to get the correct blood type for a transfusion and makes it very difficult to mix up blood tests. A more controversial use in medical facilities is tagging the patients with wristbands; this is most interesting when it comes to dementia patients and children. Whether or not it is ethically correct is still being discussed.

3.3.1.2 LOGISTICS

The logistics industry have slowly started using RFID and seen the use of it. There are many solutions on the market which allows tagging of pallets. This is the most common logistical use of the technology, but there are also solutions which tags the items more individual. Another use of RFID in logistics is shipping containers, these are large and they all look alike, so a fast and simple identification method is very helpful when a boat or at the dock is filled with them.

3.3.1.3 LIBRARIES

Libraries have been using barcodes to register in and out books for quite some time. It is looking like they are moving more and more over to RFID. Seeing it offers faster registering, easier to keep inventory and offer better security than the barcodes.

3.3.1.4 RETAIL

Retailers have also started to use RFID, not only for theft securing. Other things RFID can do in retail store are to monitor consumer behavior and trends. Items that are tagged is much more easy to find, one can more easily maintain stock-out by for example tagging the last item in the shelf of one of the products and registering when this is sold. Then there is most likely no more of this product in the shelf. ^[29]

3.3.2 COMPANIES WITH SOLUTIONS

3.3.2.1 IDZONE

IDZone is a Danish company that delivers RFID solutions. They offer to fully implement the system both with hardware and software. Some of the projects they have completed is tracking of food from it is taken out of the ground until it is on the consumers table, tagging of tools in a workshop, and many more. In addition to Danish costumers, they also have a couple of Norwegian companies on their client list. ^[12]

3.3.2.2 INTERMEC

Intermec has offices in Sweden but are a company with origins in the US and is one of the world leading RFID companies. They both produce tags, antennas, readers etc. and offer support to set up a full blown RFID system. They also have different types of software tailored to suit their hardware. ^[13]

3.3.2.3 RFID CONSTRUCTORS

RFID Constructors is a company located in Sweden. They specialize in making RFID solutions for different purposes. One of their cases was to secure the workers at the Aker yards shipyard in Åbo Finland, this was solved by adding a RFID tag to each workers helmet, which are mandatory to always wear. They positioned a reader at every entrance to the ship, and then the system could at any time know how many workers were aboard the ship. This is very useful information if for instance an accident like a fire should occur. ^[14]

3.3.2.4 SUPERRFID

One of the Chinese vendors is SuperRFID. They have developed a system to use on school children, the system can for instance send the parents a message to let them know their child has safely arrived at school and that the kid has left school. It can also be used to automatically take attendance in class. SuperRFID also produce their own hardware, they offer both tags and readers from their stock. ^[15]

3.3.3 RFID MANUFACTURERS

There are a lot of companies making RFID tags, readers and antennas. Some specialize in just tags, while others deliver the whole range of products. More or less all the production of these items is in Asia, such as India, China and Taiwan.

3.3.3.1 MOTOROLA

Motorola is an US company well-known for their cell phones and other communication devices. They also have a large RFID department, which produce all kinds of tags, readers, antennas and other RFID accessories. In their stock they have an own line of tags for asset management, specially designed to cope with handling of the equipment and to be attached to rough surfaces. ^[16]

Name	Type	Frequency (MHz)	Range
Cargo Tag	UHF Gen 2	865.6-867.6	≤ 6.09 m

3.3.3.2 TEXAS INSTRUMENTS

Another company best known for other products, such as calculators that has jumped on the RFID trail is Texas Instruments. They offer a full range of products as well, though their tags are limited to the low-frequency and high-frequency bands. They do not offer ultra-high frequency tags. ^[17]

Name	Type	Frequency (MHz)	Range
Tag-it Inlays	HF	13.56	< 3
LF Transponders	LF	134.2 kHz	≤ 100 cm
Packaged Transponders	HF	13.56	< 3

3.3.3.3 CONFIDEX

Confidex is a Finnish company that makes RFID tags and labels. Their producing factory is in China, and they regard themselves as a leading actor in the market. They have made tags specialized for wooden pallets and tires in example. ^[18]

Name	Type	Frequency (MHz)	Range
Ironside™ on-metal tag	UHF Gen 2	865-868	4-8 m
Survivor on-metal tag	UHF Gen 2	860-969	4-8 m
Halo™	UHF Gen 2	865 - 868	4-5 m

3.3.3.4 HUAYUAN

Huayuan is Chinese company out of Shanghai. They have customers from all over the world and a wide range of UHF gen 2 tags in their stock. They can also make customized tags that suits the customers need. ^[19]

Name	Type	Frequency (MHz)	Range
T12048 Card	HF	13.56	< 3
U CODE HSL Card	UHF	869-960 and 2.4GHz to 2.5 GHz	≤ 8.4

3.3.3.5 IMPINJ

The Monza tag from Impinj was the first UHF gen 2 products to receive EPCglobal certification. They are based out of Seattle in the US, but have offices in Europe and Asia as well. They have two main tags they deliver one with regular 96 bit EPC and another with 64 bits extended storage. [20]

Name	Type	Frequency (MHz)	Range
Monza	UHF gen 2	860-960	< 9 m
Monza/ID	UHF gen 2	860-960	< 9 m
Monaco/64	UHF gen 2	860-960	< 9 m

3.3.3.6 TAGSYS

Tagsys is a leading company within RFID solutions and they have a big variety of tags, both rigid tags and flexible tags. They also have readers and other equipment in their stock, such as a 3d RFID tunnel which can be mounted onto a conveyor belt and read any items with tags passing through it. Their equipment have for instance been used by Radobank (Large Dutch bank), where the bank put HF RFID tags into seal bags, and a reader in the night safe, to keep track of when they were delivered etc. [30]

Name	Type	Frequency (MHz)	Range
AK Family of UHF Gen 2 Tags	UHF gen 2	860-960	< 9 m
370L	HF	13.56	< 3 m
Nano Laundry Tag	HF	13.56	< 3 m

3.4 HEALTH RISKS CONCERNING RFID

RFID generates an Electromagnetic Field (EMF), the radiation from such field is well known to damage biological materials such as human tissue etc. if exposed to high quantities. This radiation can be classified into two different types.

- **Ionizing Radiation**

Ionizing Radiation is particles or waves with high energy, which have the ability to detach one or more electron, form an atom or molecule. If enough such radiation is radiated through a biological system and it can cause for example DNA damage or mutation effects. ^[31]

- **Non-Ionizing Radiation**

Less energetic than the ionizing radiation, this can still be dangerous for people; it can affect the eyes, skin, and other tissue. This type of radiation is used in microwaves for example, where it is used to heat biological materials. This is also the type of radiation emitted from RFID tags. ^[32]

There has been some research done to investigate the possible health risks concerning RFID. One of the reports given out is from the RFID 4SME (rfid4sme.eu), which is a project partly financed by the European Union. They state in their report that non-ionizing fields are known to cause short-term biological effects, mostly related to heating of tissue. They also mention that several research projects have been done to link such fields and cancer, but there is no scientific evidence to support this link. The report point out that the crystalline lens in the eye is vulnerable, since it does not have any blood flow. Tests done on rabbits show that they developed cataract within 30-60 minutes, after being exposed to high amounts of RF energy. ^[33]

There has been set a limit called Specific Absorption Rate (SAR), in the report they operate with a limit at 4W/kg, which is the maximum amount the human body can drive off without increasing the body temperature more than 1°C. Though the American FCC (Federal Communications Commission) has set their limit to 1.6W/kg and the European Union have their limit at 2W/kg. ^[34]

In a paper written by Darmindra D. Arumugam and former Director of the Auto-ID Labs at MIT, Daniel W. Engels, present a study of the RF field generated with UHF RFID tags. In their analysis they find that the SAR of passive UHF tags in muscle tissue is 0.007574W/kg which they conclude is over two times of magnitude lesser than the FCC limitation safe limits of RF exposure. They also conclude that a RFID tags is less harmful than a mobile phone, which also operates on the UHF band. In addition they add that long time exposure is still a field of research and thus no conclusion can be drawn on this question. ^[35]

The World Health Organization (WHO), have since 1996 worked on the International EMF Project, which aims to clarify what health risks that exists if exposed to Electromagnetic Fields within the frequency range from 0 to 300 GHz. They have by now released a few fact sheets, but there is yet to come anything specific about RFID. The project is scheduled to be finished by the end of 2010. It is expected that this will deliver a comprehensive review of how EMF can be a health risk both in short term and long term exposure. ^[36]

4 THE CASE

Company X noticed in the last inventory check that certain expensive items were not to be found. The CEO of the company had heard a lot of exciting things about the RFID technology and is very interested to find out if they can use it to make sure that they keep better control of their inventory.

They have 200 employees and are renting a four storey building. The building has two main entrances and two fire escapes. There are a lot of people going in and out of the building during business hours. The company wants specially monitoring of the server room on the first floor, the archives in the basement and the ground floor storage room. The contents of the server room should never be allowed to leave the room without any special permission, if anything leaves the room without permission they want to be alerted. In the archives and the storage room they want a solution to register items in and out. The initial registration of items should be done by the administrator of the system when the item is tagged. The registration of items in and out of the archive room and the storage room is limited to the employees who have access to them.

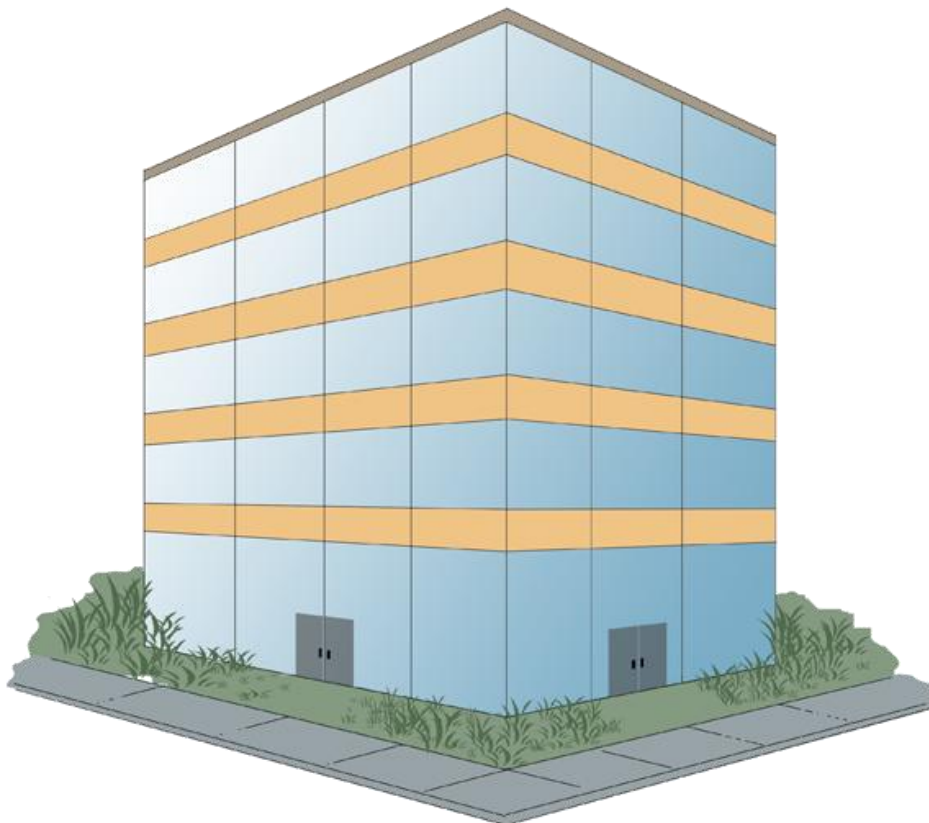

Figure 15: Company X office building

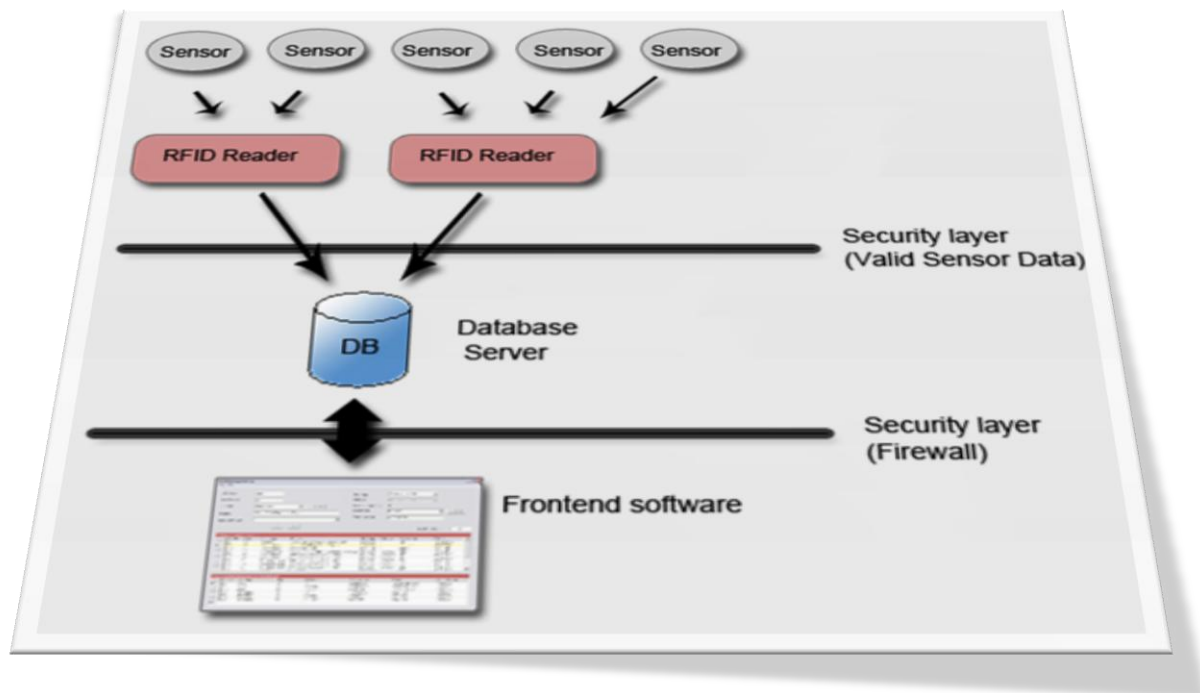

Figure 16: System flow chart

The sensors should be connected to readers and they again should always be linked up with a database server, where every movement of inventories are saved and kept track of where an item is located at all times.

The database should be linked up to a central logging system where there is possible to get status of where an item is located, which items are located inside the building and what items are not, the history of an item and so on.

The central logging application should contain modules to administrate the system. It should be possible to add/delete items, register items in/out, view status of items, add/delete users, and view status of reader array. In addition to this, it should be possible to give registered items alert properties, like any restriction and what kind of alarm to be given i.e. SMS, E-mail etc. The central logging application should also have a report system, where e.g. outline of items could be made.

The central logging application should not be accessible for all the employees, only the ones who have administrative rights. The regular users might be granted access to a small part of the system which will be used for registering already added items in and out of their rooms, such as the archive and storage room.

4.1 LIMITATIONS

The thesis will give a thorough study of the case looking at which RFID technologies and solutions are suited. There will be suggested different approaches to solve the case, with pros and cons concerning each approach. The frontend application will only be shown in concept and will not be implemented. The design and structure of the database will not be a part of the solution given in this thesis.

5 SOLUTION PROPOSALS

5.1 CHECK LIST

This subchapter will give a quick run-through of the things you need to consider when deploying an RFID system.

5.1.1 TAGS

It is important when choosing RFID tags, to choose the frequency range best suited for the use. In some cases it is better to use HF in other UHF etc. It is also important to be sure that the frequency corresponds with the legal ranges for the country or area.

5.1.1.1 TYPE AND CLASS

As mentioned in the background chapter there is three main types of RFID tags, Passive, Semi-Passive and Active tags.

- Passive tags
 - Small and easy to fit on items.
 - Cheap
 - No need for battery
- Semi-passive
 - Could be beneficial in some scenarios
 - Costs more, but you pay for more functionality

- Active
 - Full-control
 - More tracking possibility
 - Might be a solution on very expensive or sensitive items.

Each type of tags has different pros and cons, so one has to evaluate which are the best fit for the project.

There are several kinds of classes of tags, which possesses different qualities when it comes to reading and writing to and from it. This is mostly important if the choice is passive tags; active and semi-passive tags are usually always read and write many times. The passive tags have two different settings, either read-only or write-once and read many times.

5.1.1.2 READ PERFORMANCE

Regarding read range, this has a lot to do with what frequency that has been chosen, the different frequencies give different read ranges. This is important to think about, if for example the tag is going to be attached to a material, which might affect the range which it can be read. Another issue for the read performance is the reading efficiency; this is measured by the ratio of successful reads versus incomplete reads.

Radio frequency interference can also have an effect on the read performance; this interference can originate from for example, electrical drives, motors or RF transmitters. The interference is mostly present if the source of it is close to the antenna.

It is also possible to have tags with more information on it than just a EPC code, this can be interesting for scenarios where you want to get some info about the tagged item when reading the tags, for instance in a library maybe you want the book title and author listed on the reader interface. Though this will of course make the size of the data transferred bigger.

5.1.1.3 TAG FORM AND SIZE

Tags comes in many forms and shapes, some have form like a little disk, others like a wristband for humans to wear and smart labels which looks more like a sticker. The smart label is very small and simple to use on inventory like for instance a laptop computer or similar items, but for instance a transport pallet there are bigger and more rugged tags which can withstand some beating. Tags have to be chosen so they are well paired with the items they are to be fitted on.

It is also important to make sure that the tags follow the standards that are set by organizations like ISO and EPC. The importance of this has to do with it being compatible with as many systems as possible and it also helps to keep the uniqueness of the tag info if everyone follows the standards. It is of course vital that the tag and reader follow the same standard, if they are to be able to communicate properly.

5.1.2 READERS

As stated above the readers have to correspond with the tags, so it can read the frequency the tags are operating on. Readers come with different numbers of ports to connect antennas, from one to eight ports. Thus, if you want to have more than one antenna connected to the reader, it is important to take this into consideration. There are two main types of readers as we have stated in the background chapter, mobile and stationary ones. When building a RFID solution it is often preferable to have a handheld reader with WLAN connection to use when walking around and for instance doing inventory, in addition to the stationary ones which is to secure exits, rooms etc. It is also two ways to connect the readers to the server, either wired or wireless. If wireless is chosen one should be aware that this might need some more security measures as it is easier for outsiders to gain access to a wireless network.

When choosing readers one should also make sure that the vendor and producer have made it easy to upgrade the firmware and to get access to the newest firmware. This is important if there are flaws or security holes in the current firmware which can be exploited or cause unnecessary crashes.

Another thing that needs to be taken into consideration before choosing a reader is that it is within the legal limit of EMF, for Norway this is 2W/kg.

5.1.2.1 MANAGEBILITY

Regarding managing of the reader it is preferable that there is a simple solution to access the reader and administrate it, for example via telnet or a simple web user interface. And if the management can be integrated into another system without too much work this could also be a great advantage. The easier and intuitive the administration of the reader is, the better for the users, concerning for example the need for training and support.

5.1.3 SELECTING ANTENNAS

There are two type of polarization of antennas, circularly and linearly polarized antennas. If the tag orientation is arbitrary, unknown or unpredictable, we should use circularly polarized antenna, because circularly polarized antenna have both horizontal and vertical components. If tag orientation is known, we should use a linear polarized antenna to receive the maximum power and thereby increase the read range.

We should also be aware of standards and regulations regarding the characteristics of RFID systems, such as the allowed operating frequency and allowed maximum power emission by the antenna.

5.1.4 SELECTING TRANSMISSION LINES

Transmission lines have to be used between antenna and readers, and make sure that the cable length is not too long. With longer cables we get greater chance of loss of data. Most commonly used transmission lines are coaxial cable and shield pair cable. With coaxial cable we will get low loss of data and therefore possibility for longer cables.

5.2 SYSTEM DESIGN

In this chapter we will present a proposal for how the system can be designed when it is put into action. We will give a presentation of how the data will flow from the tags to the end user.

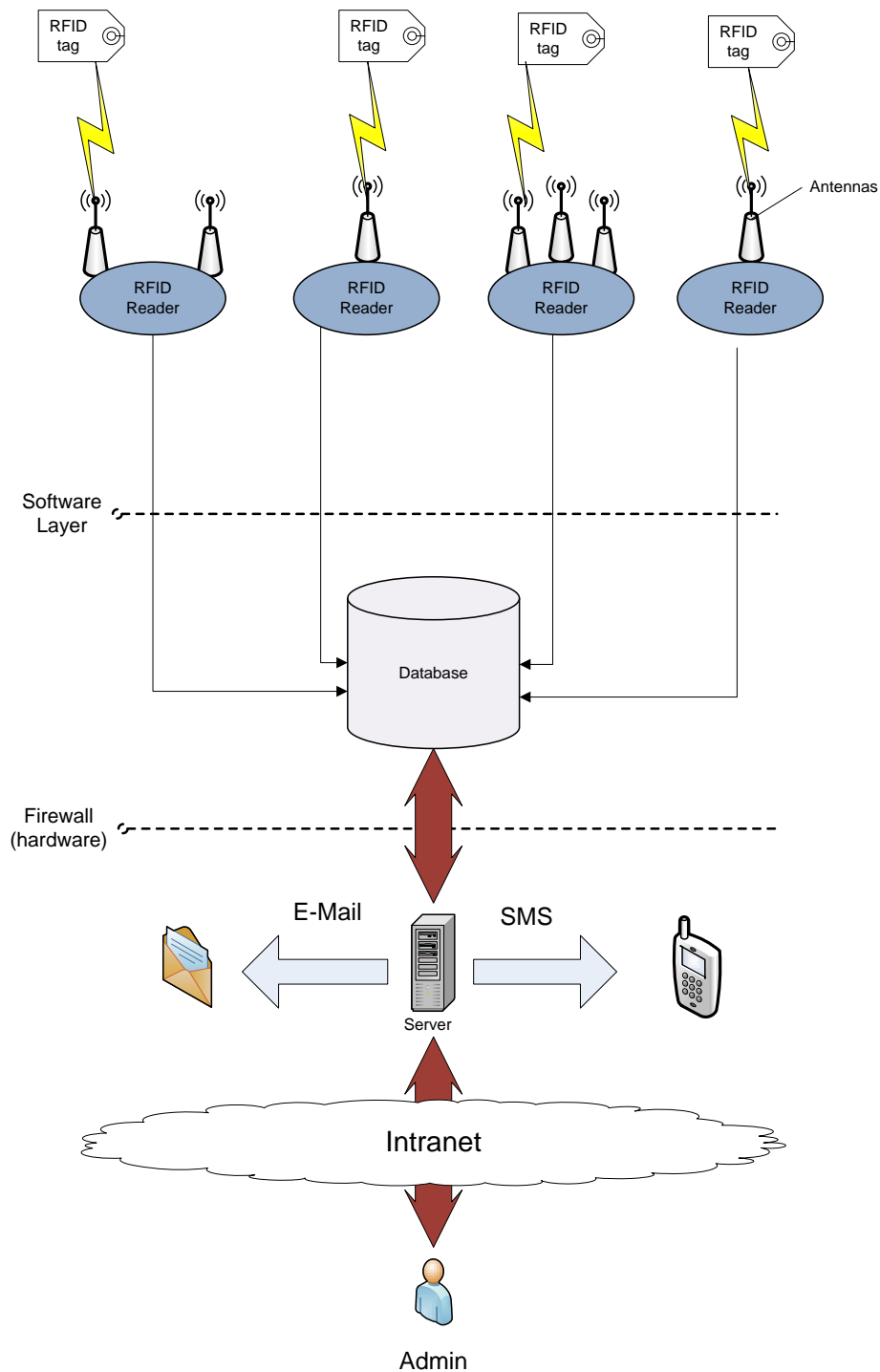

Figure 17: System design

The dataflow starts with the readers inducing the tags when they are within range, then the tags send their info via radio waves to the readers via the antennas. From the readers the information is sent to the database, but before it is stored here, it will pass through a software layer which will be used for two purposes. The first is to convert the data from the readers to the format type stored in the database, because in most readers the data is not represented in human readable format. Thus this software layer will perform a transformation of the data. The second function of the software layer is the check if the data is valid, for instance if the code fetched from the tag corresponds with EPC and so on. This is to ensure that the data in the database at any time can be trusted to be correct. The transformation of the data can in most cases be void if the solution is based on smart readers, then this transformation can be done with software on the reader itself and thus the need of doing this job on another entity is removed.

The database server will be where all of the data concerning tags, items, and users will be stored. Everything from EPC code to username and where an item was last logged. To create a good and logical model and structure for the database it is vital in order to have the data from the tags and readers represented in a way that makes it easy to create a good and solid frontend to maintain it.

Between the database server and the server running the frontend application, there will be a firewall, preferably a hardware based firewall, as these are usually the safest. This layer of security is to prevent from unwanted access to the data. The frontend application will be a browser based portal, which we will go more thoroughly into in chapter 5.4. The access to this application should preferably only be allowed within the intranet of the building, but security measures should be made in order to make the possibility to access the system via the internet. Using a browser based frontend portal also removes the need of installing anything on the frontend users computer, all that is needed is access to the network and proper login information. Through this frontend application the administrator can keep track of items, register new items and remove items that are no longer to be in the stock.

In the areas which registration of items in and out occurs, it will be given limited access to change entries in the database. For instance this can be solved by adding a boolean attribute to the database entity which represents the item. Every time an item is read by the reader in the room it is registered in or out, this attribute changes to the other value and thus making the registration go automatic.

The arrows on the figure pointing towards E-Mail and SMS are to symbolize the two alarms that can be sent. In the database the item entities have an alarm attribute, the value of this decides what kind of alarm to send if the item passes an antenna it is not suppose to pass. The alarm is then sent to the administrators so these persons are made aware that an item is illegally removed from the room or the building. Even though SMS probably is the fastest way to get this to the administrators, because a cellular phone is something one usually always carries, it is important to remember that SMS is not a prioritized service in the mobile network and thus can experience substantial delays. Therefore an E-mail which is the most basic alarm should be sent in all cases as a backup if the SMS experience delays.

5.3 PROPOSALS AND POSSIBLE SOLUTIONS

In this chapter we will present proposals and solutions for the case scenario. Describing which RFID technology we propose as a solution and how to build an infrastructure to support these proposals.

There are some attributes that are general for all the following proposals, such as type of EPC code scheme. Here we propose to use the general type of 96 bit which is described in chapter 3.1.2, this can hold the information we need and offers enough unique codes for our problem owners needs.

Another general choice is the type of tag. Here we suggest using smart labels, since these are very similar to the type of markings IBS Security use today and they are small and easy to attach to almost any kind of surface.

5.3.1 ENTRANCES

The entrances will be the key area to secure the flow in and out of the building, and need to be covered with enough readers and antennas so that one cannot easily slip a tagged item through the doors. Thus the suggestion to solve this is to put three antennas around each entrance, one above the door and one on each side. These antennas should preferably be circularly polarized in order to cover more of the door opening.

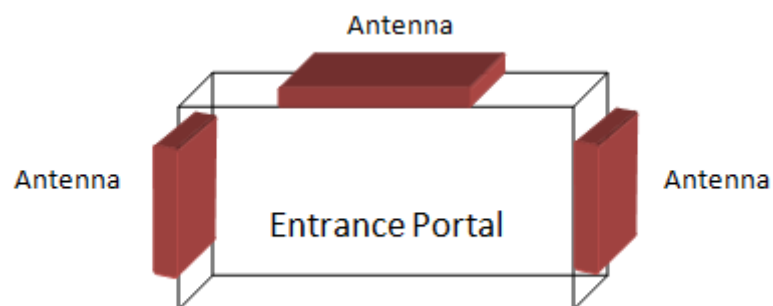

Figure 18: Entrance portal

For the items which should be logged, going in and out of the building we think UHF gen 2 will be the

better solution when it comes to tag and frequency, as it offers good reading ranges and gen 2 tags have built in collision detection. Of course it is also important to make sure that the frequencies of the tag and reader, plus that the level of EMF emitted by the reader/antenna is within the regulation of the country it is to be set into life.

In the case there are four exits, two main exits and two fire escapes. Therefore two readers with eight antenna connections each should suffice to cover the need for the entrances. Though one thing to keep in mind is the cable length, if the cable length gets too long this can give greater risk of data loss. Thus one should keep this in mind when positioning the readers.

Once a tag is read in the portal it will be sent to the database and processed, if the item is not to leave the building, there will be sent an alarm. This alarm system will consist of three stages.

- E-mail
For items that preferably should stay in house but is not vital to keep in-house
- E-mail and SMS
For items you want fast notification about leaving the building.
- Sound, SMS and E-mail
This is for very important items that there is no reason for leaving the building at all

For the entrances we suggest using smart readers, as it is most likely to only be UHF tags with plain EPC codes on them, so it is simple to do the needed transformation on the built-in module on the smart readers. But this can be weighed a bit when considering the entire case, if most of the other areas are best suited for simple readers, which are cheaper, it is most likely more cost effective to build a software layer covering all the areas and go with simple readers in the entire solution.

5.3.2 STORAGE

In the storage room there will be a lot of items going in and out. Here we propose to either have a handheld reader, which the person fetching or delivering the item register the transaction with. The other solution is to have a fixed single linearly polarized antenna where the item can be scanned below. There might also be need to know who borrows the item, this can also be solved in two different ways. Either that all employees have RFID identification card which can be swiped past the reader, before or after the item is read, and additionally register which employee removes the item from the room. Most companies already have ID cards with magnetic strips or similar solutions for their employees that are used to get into the main entrance and restricted rooms. Tags can be added into the same cards or simply just added onto the cards as a paper-thin label. What is important if this proposal is used is to make sure that the tags cannot be used to track the whereabouts of the employees, as this is a privacy law infringement. The second proposal to solve it is to have a simple logging frontend where the user just scans the item then gets a simple interface up on the portable reader or a computer in the room where you simply just add your name or id number to verify who is removing the item from the room.

For the storage room UHF gen 2 tags seems to be a good solution, they offer good reading distances and a good possibility to do bulk readings if necessary, with their built-in collision detection. The tags should also be able to handle rough surfaces and rough treatment. A lot of the storage room items have metallic surfaces, and thus the need for tags with metal surface qualities is vital.

For the type of reader to choose here other than the question about handheld or a fixed reader with a single antenna, it of course needs to be compliant with the frequency of the tags. A simple reader would be sufficient as the sorting and parsing of data can be done on the software layer between the readers and the database. For instance when connecting which person is in possession of which item etc. As for the choice of handheld versus fixed for this room, the handheld will most likely be the most versatile solution as it does not put such a high demand of the location of the tag, as the reader can easily be pointed towards the area of the tag. With the fixed version one has to be more careful about the positioning of the tag, in order to make it user friendly. Choosing a handheld reader will simplify the process of keeping storage, since you can quickly walk around the room and scan, which is another good reason to have UHF here, considering the reading ranges it can give.

5.3.3 SERVER ROOM

Server room is an important area where security should be very high. We want to know everything that is moved in and out of this room. Therefore we will propose to place a portal here, just like the building entrances. This means that there will be three antennas, one above the door and one on each side of the entrance to the server room, connected to a reader. These antennas on the portal should preferably be directional in order to register the items or inventory that passes right through, without having misreads from the items inside the room. The signal from the antennas are very high toward the direction the antennas are pointed.

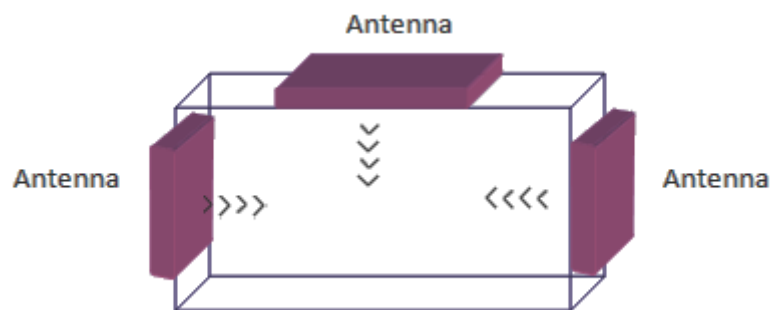

Figure 19: Server room portal with directional antennas

The items which should be logged in and out of this room could be marked with UHF gen 2 or HF labels. We think this will be a good solution since the entrance to the server room would not be as wide as the building entrances and therefore HF with read range up to three meters could also cover the entrance area. If we go for a solution with HF tags, then it should also be considered having HF readers at the building entrances as well, to register the items that belongs in the server room in and out of the building, and not only the activity in and out of the server room. Whether choosing HF or UHF gen 2, it will have to be made sure that the tags are ferromagnetic so that they can withstand disturbances from the metal surfaces they are attached to.

The most economical solution may be to use UHF gen 2 tags and readers in this room as well, then the items can be registered at building entrances as well without anymore accessories.

Regarding smart or simple readers, we propose going for a simple one. The items in here will most likely contain plain EPC codes on them like other items that are located inside the building, and therefore use the same preferences everywhere.

5.3.4 ARCHIVES

The archive room contains a lot of items or folders that could be borrowed by the employees, and this should be registered in some way. We will propose that this room has a scanner area where a computer is connected to a reader or just a handheld reader connected to the rest of the system, where employees could register items in and out the room manually. In this way it will always have an overview of who possesses the items from the archive room.

Since we propose using handheld readers in this area, LF or HF can be used to mark the items. The items would not be registered in and out the building if we don't have a LF or HF reader at the building entrances. There is no need for that, since the archive system has a separate user interface where the users register items in and out of the archives manually.

The tags used in this solution could contain info about the items they are attached to. In this way the items can be scanned in one part of the room, and read the additional info and pick the item one is looking for without e.g. turn over the leaves of a book or folder.

5.3.5 OVERVIEW

In the table below we have summarized the proposed solutions for entrances, server room, archives and storage room.

Position	Frequency	Reader type	No. Readers	Antennas	No. Antennas
Entrances	UHF	Simple, Stationary	2 total	Circular	3 per 12 total
Server room	UHF/HF	Simple, Stationary	1 total	Linear	3 total
Archives	LF/HF	Simple, Handheld*	1 total	Linear	1 total
Storage	UHF	Simple, Handheld*	1 total	Linear	1 total

Table 8: Overview of the solution proposal

*Can also be a stationary reader with single antenna.

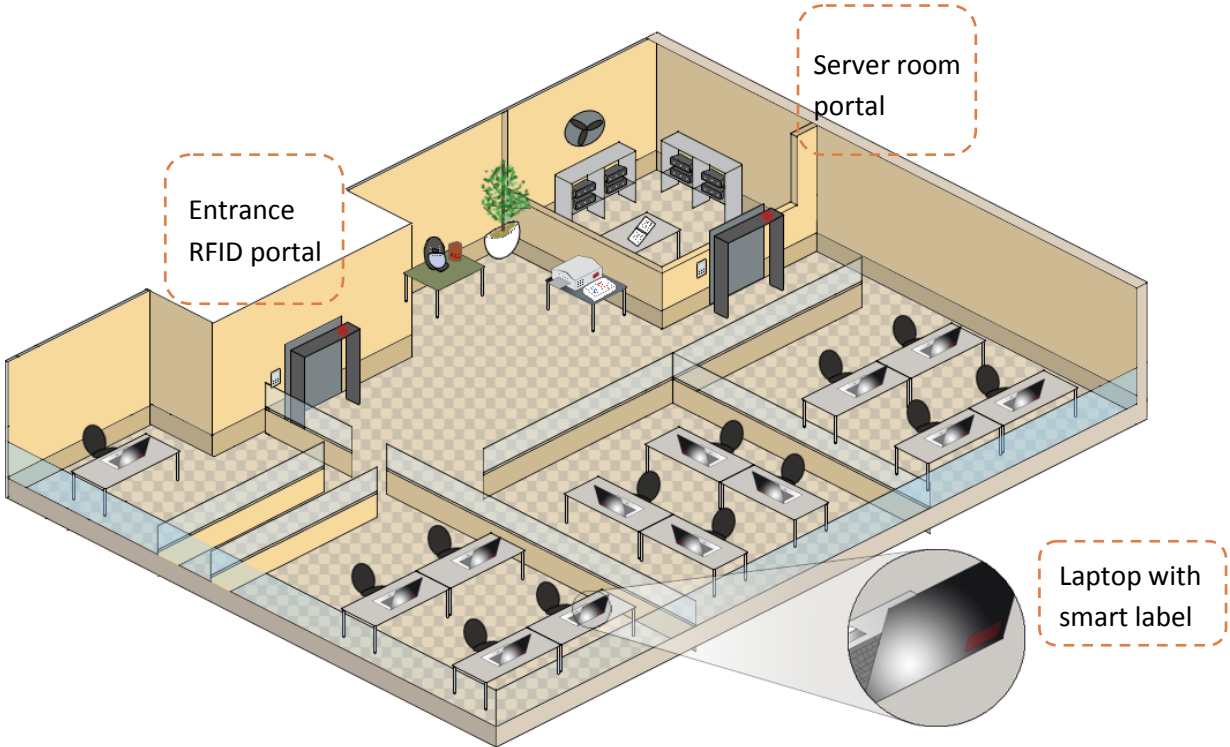

Figure 20: Solution proposal for 1st floor where the server room is located

5.3.6 ADVANCED FEATURES

In addition to the proposals exploited in the sub chapters above, there are also some more advanced features that can make the system to a more complete security solution for the building. For instance can each floor be secured with portals, so that the items can be tracked more thoroughly. In addition all the windows can be secured with readers and antennas to prohibit any items being smuggled out of the building through one of them. This is security measures that most likely is not an option for the average company, but might be for those who have extra high demands on keeping track and control of the items within the building it would be something to consider. This will of course be a much higher cost to purchase the items needed to make this infrastructure and will also make the need for a more advanced software solution, but if the items that are protected are valuable enough it would probably be a smart long term investment.

5.4 FRONTENDS

In this chapter we will present a suggestion for the frontend solution or the software design, for our system.

The frontend solution could be a windows application or a portal solution where the portal could be accessed through the intranet. With the windows application solution, there would be a limitation from where one could access the system, one will have to be in the company ground to access it and this makes this solution not so flexible compared with the other solution.

The other solution is the portal solution as we mentioned above. With this solution the information can be accessed from anywhere there is an internet connection and administration rights to use the portal. We will propose a web portal solution for our system. The frontend solution we present later on in this chapter is the solution that covers the case and the advanced features.

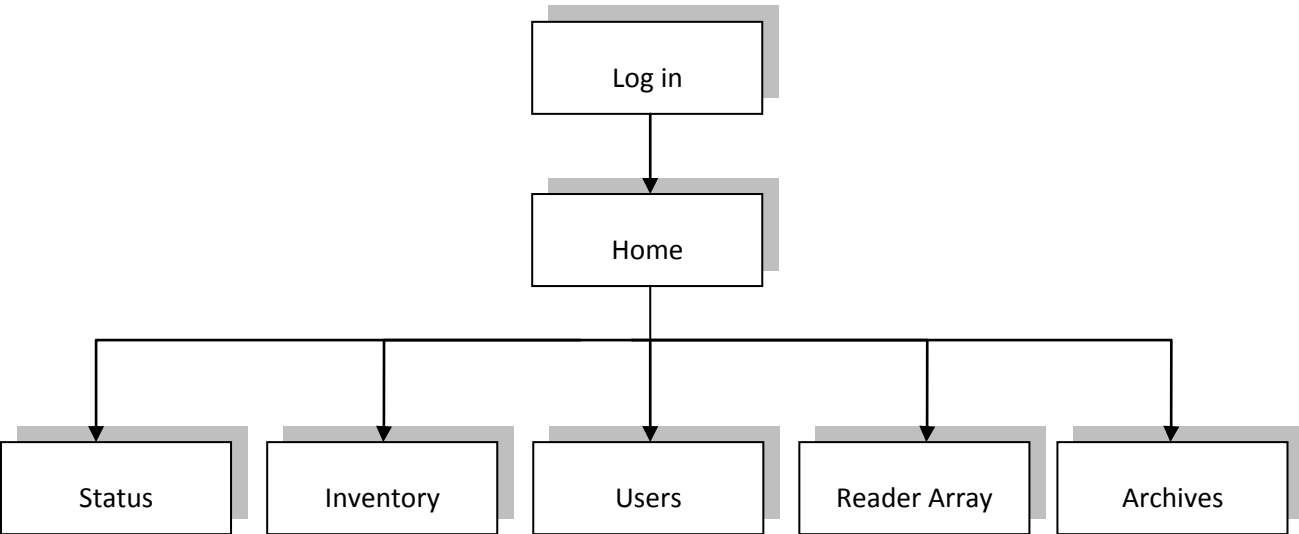

Figure 21: Frontend overview

The user of the web portal will first have to log in to access the system. When the concerned is authenticated and logged in to the system, the user will have access to other parts of the system, which are a home, status, inventory, users, archives and reader array pages.

The figure below shows how a log in page for the portal may look like. Only registered users can enter the site. When users are logged in, they will be redirected to the home site. In the home site the latest activities will be shown, logs of alerts and other functions the company X wants on their main portal site.

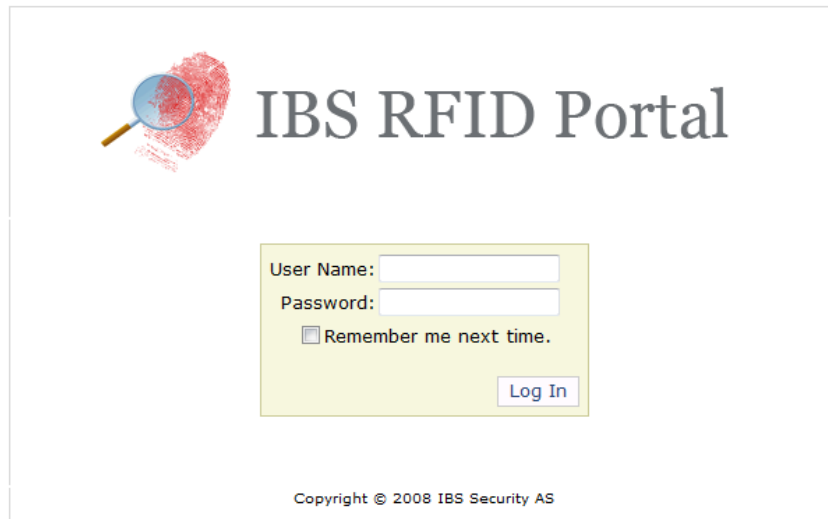

Figure 22: Log in site for the web portal

Overview of the system is a very important functionality and located in the status site. Here we could monitor floor by floor to see which items are located on which floor and maybe highlight the items which are registered somewhere else but currently located in the floor we are looking at. Of course, for a solution like this, we will need to have a portal like those at the building entrances on each and every floor entrance. If we do not, we could only have a simple solution and select the whole building and get an overview of the items that are located inside the building and outside the building.

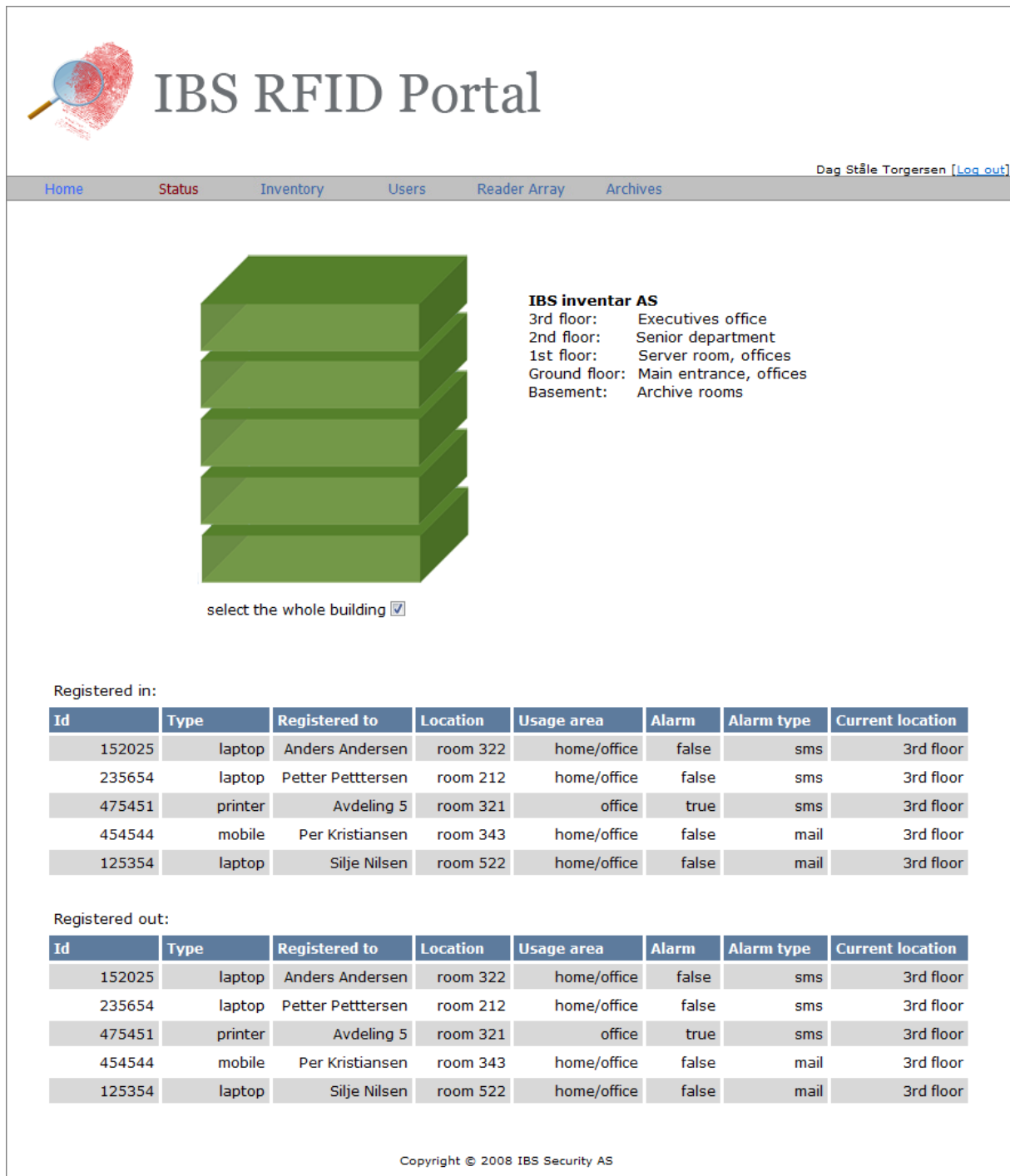

Figure 23: Overview of the entire building status

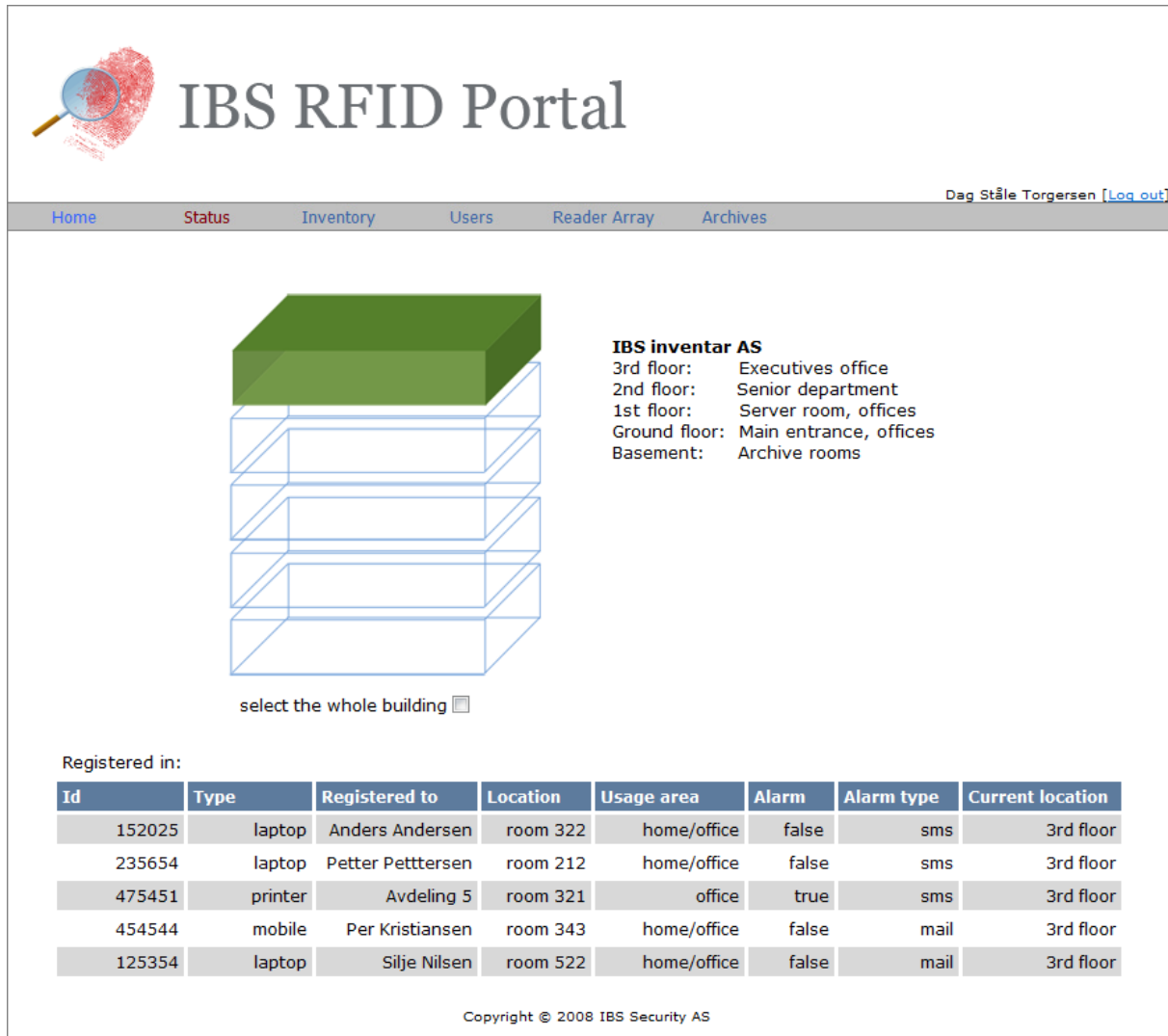
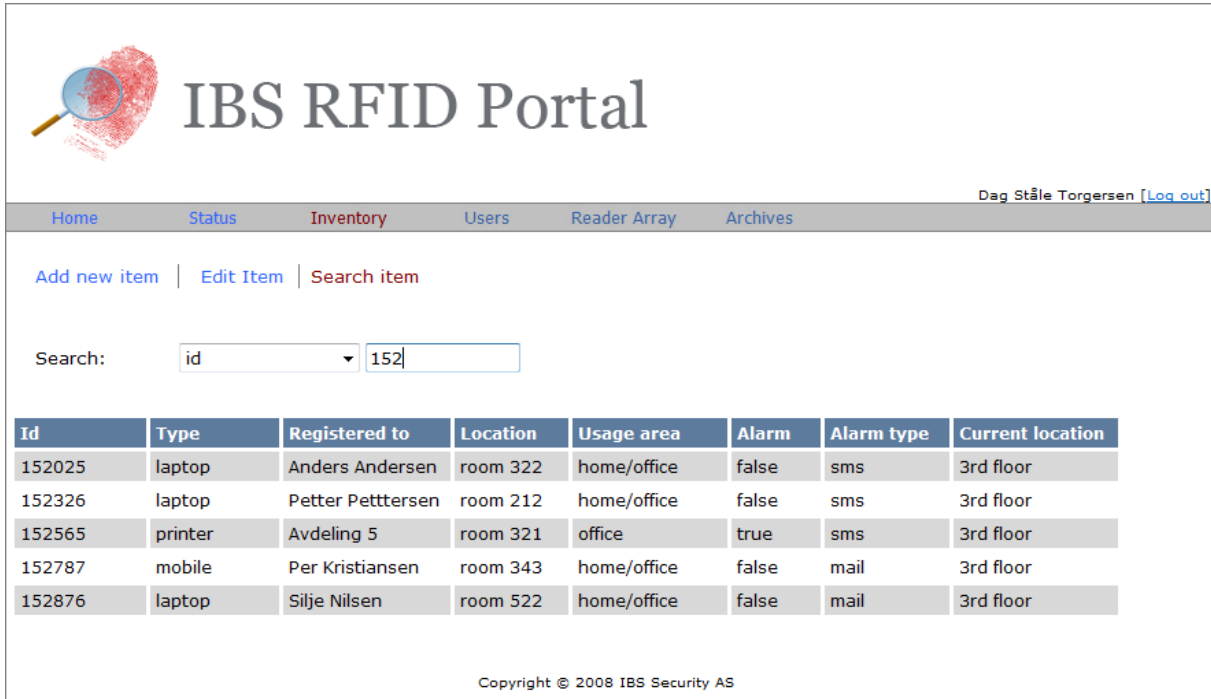

Figure 24: Overview of the 3rd floor status

In inventory site is where the registration of new, modification and delete of old items takes place. Here it would be possible to register all the information the company wants to register about an item which would be saved in the database, information like id, type, to whom it is registered to, the location, if it is location regulated with an alarm which will go off if the item leaves the area, type of alarm and so on. In the inventory site, we could also locate a particular item with an id and get the status of it, like where it is located at the moment and the history log with timestamps when the item entered and left the different areas or the building. It is also possible to implement a solution which shows the status of items after criteria like location, where they are registered to or type and so on.



The screenshot displays the IBS RFID Portal interface. At the top left is a logo featuring a magnifying glass over a red fingerprint. The main title "IBS RFID Portal" is prominently displayed. A navigation bar includes links for Home, Status, Inventory (highlighted in red), Users, Reader Array, and Archives. The user "Dag Ståle Torgersen" is logged in, with a "Log out" link. Below the navigation bar are links for "Add new item", "Edit Item", and "Search item". A search section shows a dropdown menu set to "id" and a text input field containing "152". The main content area contains a table with the following data:

Id	Type	Registered to	Location	Usage area	Alarm	Alarm type	Current location
152025	laptop	Anders Andersen	room 322	home/office	false	sms	3rd floor
152326	laptop	Petter Pettersen	room 212	home/office	false	sms	3rd floor
152565	printer	Avdeling 5	room 321	office	true	sms	3rd floor
152787	mobile	Per Kristiansen	room 343	home/office	false	mail	3rd floor
152876	laptop	Silje Nilsen	room 522	home/office	false	mail	3rd floor

At the bottom of the page, the copyright notice "Copyright © 2008 IBS Security AS" is visible.

Figure 25: Inventory list

In the users page it will be possible to register new, modify and delete users. Here it would be possible to register information about users and their rights, for example only an administrator could register items and change registered data. In here we could register portal users and other employees whom are assigned with items. Regular employees should not have access to this system, only the employees who have the rights to monitor the system.

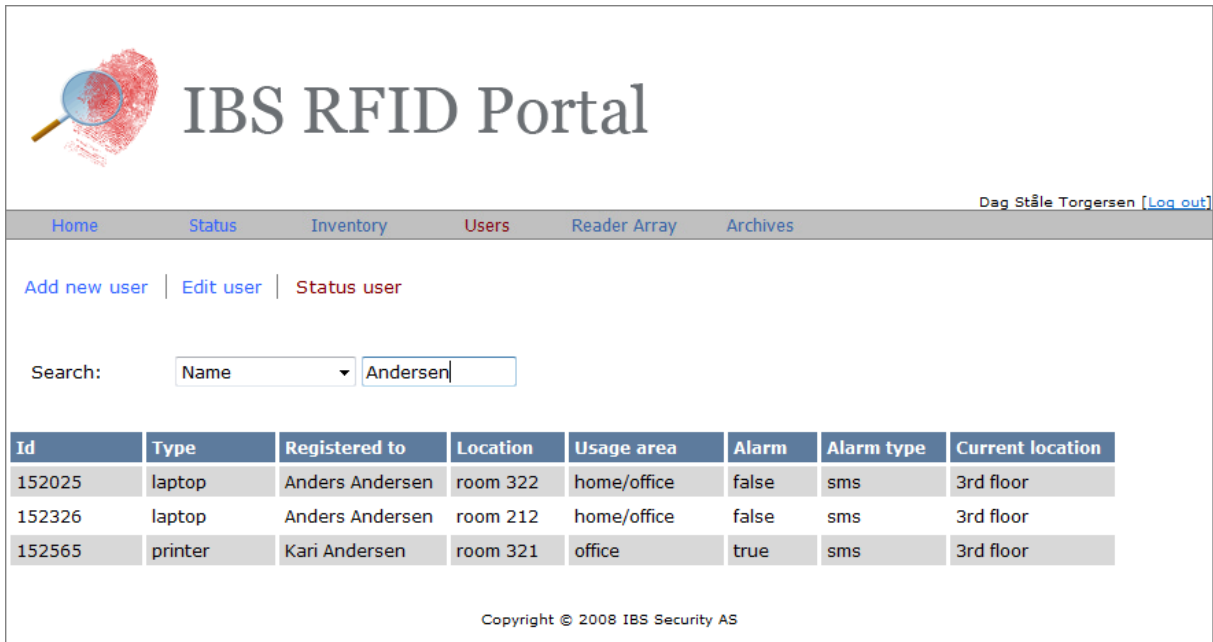

Figure 26: User list

In reader array page, it could be an overview of the readers located around the office building. That could indicate with a red color if something is wrong with the reader and green if everything is fine.

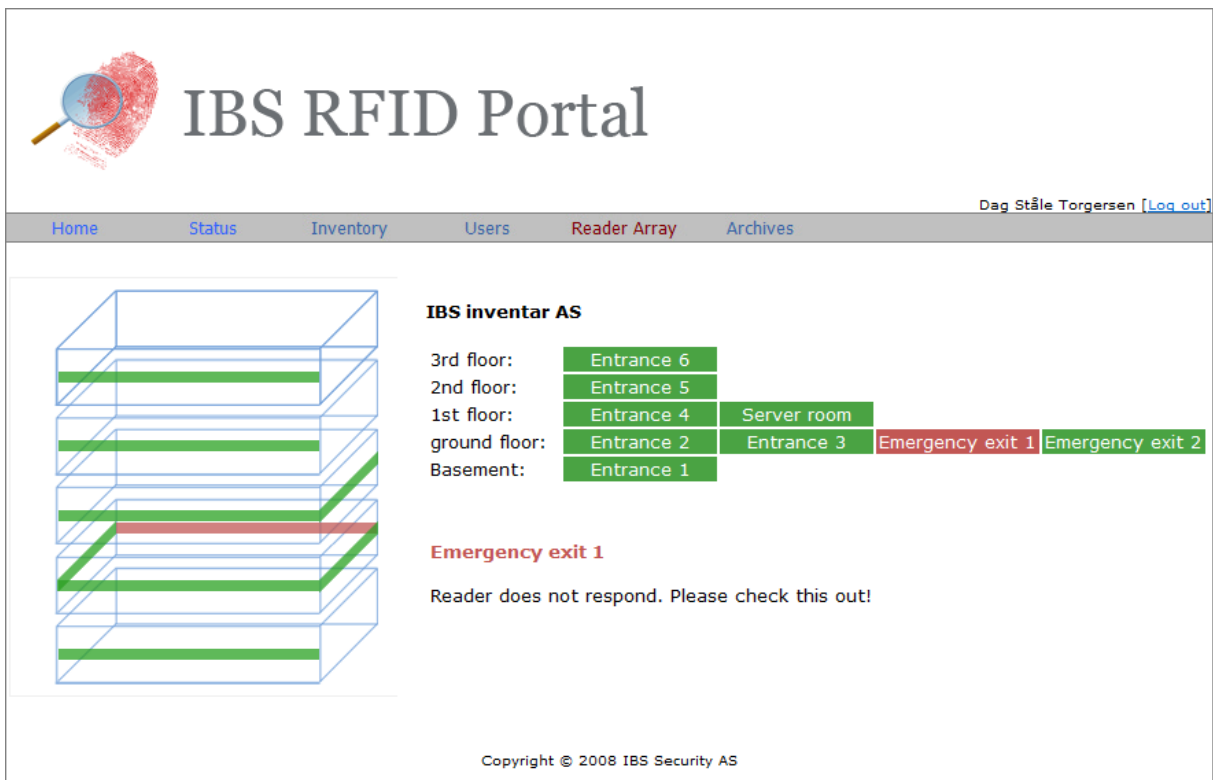

Figure 27: Reader array

In the archives page, the administrator could get a list of items that have been borrowed by the employees, and which items that are currently available for loan. In the archive rooms we will also have another frontend for registering items in and out. This frontend is connected to the portal.

6 DISCUSSION

This thesis started with the comprehensive review of the current and near future state of RFID technology. Looking at the different standards which the industries follow and also investigating into future standards such as looking into the ongoing evolvement of the established EPC standards. Time was also spent to research which similar solutions were already present on the market, and see how these could give guidelines both positive and negative regarding our proposed solution. We also researched what type of tags and readers the main manufacturers on the market could offer, considering frequency, the ruggedness and style of the tags. We also did a comprehensive search on known health risks and papers giving proof and/or discrediting them. All of the above mentioned topics will be further discussed in this chapter.

Together with our supervisor and problem owner we established a case scenario which would act as a guideline and scarlet thread through the thesis. The case was built to create a more specific outcome with precise solution proposals regarding the different rooms and sectors in the case study office building. To substantiate these proposals we had widely researched the RFID universe in order to gain the knowledge needed.

There is a lot of diversity within the RFID technology, like frequency, tag type and class, read range, cost, size and energy source among others, which has to be considered when constructing architecture for an RFID system. On the subject of choice of frequency it is two different things that are important to think about. Firstly, what range of frequencies do we need, UHF, LF, HF are all viable solutions with different pros and cons. Secondly, when the frequency range is chosen, we have to make sure that it corresponds with the country or areas frequency regulations.

In the areas we have proposed UHF this is mainly because it offers good read ranges, the new generation tags has built-in multiple read collision detection. This makes it possible to for example quickly do an inventory check in the storage room. In the archive room we proposed LF or HF, because here the reading range should be short, in order to minimize the possibility of multiple reads. The trends in the market today is also to turn more and more over to UHF after the new generation 2 standard was established, nevertheless we believe that the HF and LF are more suited in some parts of our case, such as described above.

In all the proposals we have made we have only selected passive tags. The reason for this is that this covers the needs of the case, the passive tags are small, simple to attach, offers good enough read

ranges with the proposed infrastructure and it is a lot more cost saving than its more advanced brothers and sisters. Both the active and semi-passive tags gives a lot more functionality, but this costs more and adds too little to the solution to be worth it. It also takes a lot more room on the item. It will of course offer better read range, but the need for this is not present. They also need a battery to operate and this gives them a shorter lifetime than the passive tags. The possible advanced functionalities would also require a much more advanced software solution. The passive tags can also be made in such a manner that it fits the problems owners' current scheme of marking assets, in form of smart labels. In some special cases it will be wise to choose a more robust tag which can withstand more rugged use.

The Infrastructure is built up around a database server which receives the data from the readers. The data consists of general information about tags and users in addition to the data generated by the readers. The array of readers we have proposed in the solution are adapted to fit the types of tags in the different areas. At the entrances we have three antennas mounted to form a portal around the doorways; these are all on the UHF band since the items which we are to be prohibited from leaving the building will be marked with this type of tags. The reason why we do not propose to have an entrance portal for the HF/LF band is that the items which are tagged with these kinds of tags will be registered to a user when borrowed out, and thus this employee is responsible for it. From the entrance portals the antennas are connected to two readers, this means that two entrances shares one reader, since the readers can hold up to eight antenna connections. If it is not possible to position the reader in a position so that the cable length from each entrance is within reasonable limit, more readers need to be considered. This is because the length of the cable directly influences the signal strength of the radio signal between antenna and reader. It is of course important to make sure that the readers operate within the legal and correct frequencies of the country it is used, for Norway this is 865.6-867.6 MHz on the UHF band. In the other key rooms of the case we only need one reader to support the number of antennas and thus this one can be positioned in a favorable position. In the storage room and archives our proposal put forward that both a handheld and a stationary reader can be used. These have their pros and cons, but in order to be able to make a quick inventory check, and also make it easier to position the tags, we think that the handheld reader will be the better solution. With the stationary reader the tags has to be positioned so that it is easy to aim towards the antenna, but with the handheld, this can simply just be scanned past the area of the tag. We have also proposed some more advanced features which will give a better all around security of the building and more successfully track where an item is located inside the office building. This will make a more complete solution, but as mention earlier it will

increase the cost dramatically and also create the need for a more advanced software and infrastructure.

The two antenna types, circularly polarized and linearly polarized, have some different attributes that differ them and make the one better than the other in different cases. We chose to propose the circularly ones on the entrance portals because these covers a larger area around themselves. This is important around the entrances as we do not want blind spots. On the server room there is also a portal solution, because the doorway on inside doors is narrower. We found it sufficient to have directional antennas which are more focused towards a specific direction and thus should cover a regular doorway in the best manner. In the storage room and archives our main proposal is a handheld reader, these can easily be moved so they can scan directly over the tag and thus the type of antenna is not such a big issue. In order to be able to scan the entire storage room when doing inventory it is though best if the antenna in the handheld reader is circular so that it can catch as many items as possible when swiping the room.

An integral part of the thesis was to present an infrastructural design of the whole system, e.g. where the readers are placed, how they are connected together to form a system and software keeping track of the data flow. In the proposed solution there are two software layers. The first one is between the reader array and the database; this layer will be designed to handle the data coming from the readers. Because we suggest simple readers over smart readers in all the locations, this software layer will function both as a filter to the data and to transform the data from the format it gets on the reader to the format we want on the database. Choosing smart readers would have simplified this layer, since we could have done this transformation on the reader, but since this layer is still needed to check if the data is correct it is simple to add the extra functionality and gives us more control on how things are done. The second software is a web portal that interacts with the database through a server in one end and interacts with the user in the other end, here the user being the administrators of the system. In our proposal a web portal solution is chosen over a more old fashioned and static window application, because a web portal can be used on all platforms from almost anywhere and do not require installation on the client side computer.

For the in and out registration in the archives and storage room, a frontend application could be used to control this, but instead we have proposed that each employee gets a card containing a readable tag with the employees ID in it. This way when the employee wants to check something out he first scans his card then scans the item, then the software layer between the reader and the database performs the connection between these two events on the same reader and puts the employee

down as the caretaker of the item. One other way this could have been solved was to use simple software on the handheld reader where the user wrote in his ID number after he had scanned the item. Both these solutions require trust in the employees since there are no portals on the doorways of these rooms to check if not scanned items is taken out. A solution to this possible problem would be to add a portal to the entrances of these rooms.

A part of the thesis was to do inquiries if RFID could be a danger to the health and safety of the people working in the building. RFID generates an Electromagnetic Field which in high dosages can be dangerous to biological material. After reading several papers and reviewing the results of these, we have found that with the current state of research into this area there are no proof on RFID giving long term health risk. In some cases, regarding the UHF band RFID tags and readers, there were proof that on a short term basis the effect of the Electromagnetic field could lead to heating of tissue, though the risk for this effect is a lot higher in regular mobile phones than in any RFID tags. Both the European Union and the American FCC have set limits to how high this radiation can be and in the paper by Darindra D. Arumugam and Daniel W. Engels referred to in the background, a UHF RFID tag reaches less than two times the magnitude lower than the limits set by both these authorities mentioned above. For Norway the limit is 2W/kg which corresponds with the EU limit.

The World Health Organization has an ongoing project where they map the possible health risks of the fields generated between 0 to 300 GHz; this is stipulated to be done in 2010 and will hopefully deliver more comprehensive proof if RFID is a health risk or not.

In our search for similar solutions we have found that RFID, though not commonly is used in some big trade areas, such as logistics, pharmaceuticals, retail, libraries and more. In the pharmaceutical industry it is used to tag drugs, with tags containing information about what the bottle contains and also to keep store inventory. In the logistics industry it is used to for example tag pallets, in order to log and track the whereabouts of these. One Swedish company named RFID Constructors made a solution to track workers in and out of a boat at a shipyard, by placing tags on their helmet. This system was used to keep track of how many workers were at any time inside of the boat. It becomes a very useful tool in emergency situations. We have not found any companies which market themselves on the Scandinavian market who have made an asset securing solution which covers our case. It was also difficult to find information upon which RFID technology the different companies with solutions used, as they only released a limited amount of information. A lot of companies offered to accept the task of making tailored RFID solutions, but these were often limited to using their own hardware and premade software.

7 CONCLUSION

This is a master thesis paper at University of Agder, and the goal of this thesis was to give a thorough investigation of a case, built by us, and the problem owner, IBS Security AS. In this thesis we have given a comprehensive review on how to keep track of assets or secure inventory by the means of RFID. To do so research have been done on subjects like RFID technology and standards, tags, readers, infrastructures and security issues, and also health risks.

In the proposed solution the four office building entrances will be secured by a portal around the doorway. These portals will consist of three antennas per portal, two on each side and one above the doorway, in order to cover the exit area. The antennas will not be directional but set up to grasp a wider area to make sure the entire entrance is covered and will be connected to a reader in order to link it up the portals with the administrative system and the rest of the infrastructure. Two entrances will share one reader, making it six antennas connected to one reader.

In the server room there will also be a portal covering the door, the difference from the entrance portals will be the antennas, which will be directional, to prevent misreads from inside the room, and to focus the reading area to the doorway only.

The storage room will have a handheld reader or a fixed directional antenna where the item can be scanned beneath. Our main recommendation for the storage room is to go with the handheld reader as this makes the scanning easier and faster. For the archives we propose a handheld reader where the employees can check items in and out using their id cards. Building entrances, server room and the storage room will use the UHF band and UHF gen 2 tags and readers. Archives will use the LF/HF band. All the tags will follow the latest EPC standards.

The data from the readers will go through a software layer which will filter it. The purpose of this filter will be to discard unwanted data and to convert the data from the type they leave the readers into a more human readable format, and then they will be put into the database. The data in the database will keep track of all the registered items movements and status. To administrate and follow the information we propose to use a web browser based portal as the frontend software. The portal yields the possibility to for example, add, edit and delete items in addition to follow the status of all the items stored in the database.

The research on health and environmental issues caused by the RFID is ongoing, but with the current state of research into this area there are no evidences on RFID giving long term health risk. In some cases, regarding the UHF band RFID tags and readers, there were evidences that on a short term basis the effect of the Electromagnetic field could lead to heating of tissue, though the risk for this effect is a lot higher in regular mobile phones than in any RFID tags. The World Health Organization has an ongoing research project where they map the possible health risks of the fields generated between 0 to 300 GHz. The findings of this will be published in 2010 and hopefully get some more accurate answers.

8 FUTURE WORK

Regarding the future work of this thesis, there are many areas which can be explored. One of them would be to realize the full system design, like designing the database and making the web portal solution. Before this is done, it would be important to test out the proposals given in real life. For example build a portal and test it out, see how much effect is needed to be on the antennas in order for them to cover the area required to keep the doorways covered. How does different materials and positioning of the tag affect the efficiency of the portals, is another thing that should be tested in order see how it works in practice, not just in theory.

We hope the proposed solutions can help the companies who are considering using RFID to secure their inventory.

BIBLIOGRAPHY

Follow the IEEE guidelines for references

see: http://www.ece.uiuc.edu/pubs/ref_guides/ieee.html

- [1] UiA, Bruk av kilder i skriftlige arbeider ved Høgskolen i Agder, August 2006,
<http://www.hia.no/stud/eksam/kilder.htm>
- [2] EPC Global, Tag Class definitions,
http://www.epcglobalinc.org/standards/TagClassDefinitions_1_0-whitepaper-20071101.pdf
(10.02.08)
- [3] EPC Global, <http://www.epcglobalinc.org/about/> (10.02.08)
- [4] EPC Global, http://www.epcglobalinc.org/consumer_info/faq/ (12.02.08)
- [5] RFID Journal, Electronic Product Code Facts,
<http://www.rfidjournal.com/article/articleview/219> (12.02.08)
- [6] Wikipedia, Global Trade Item Number,
http://en.wikipedia.org/wiki/Global_Trade_Item_Number (20.02.08)
EPC Global, Tag Data Standards,
http://www.epcglobalinc.org/standards/tds/tds_1_3_1-standard-20070928.pdf (20.02.08)
- [7] EPC Global, Serial Global Location Number,
http://www.gs1.no/epc_rfid/epc_rfid_s/epc_electr/sgln_seria/ (22.02.08)
- [8] EPC Global, Global Returnable Asset Identifier,
http://www.gs1.no/epc_rfid/epc_rfid_s/epc_electr/grai_globa/ (25.02.08)
UC-Council.org, Global Returnable Asset Identifier,
http://www.uc-council.org/ean_ucc_system/pdf/GRAI.pdf (25.02.08)
- [9] EPC Global, Serial Shipping Container Code,
http://www.gs1.no/epc_rfid/epc_rfid_s/epc_electr/sscc_seria/ (25.02.08)
UC-Council.org, Serial Shipping Container Code,
http://www.uc-council.org/ean_ucc_system/pdf/SSCC.pdf (25.02.08)
- [10] ScienceProg.com, How does RFID tag technology works ,
<http://www.scienceprog.com/how-does-rfid-tag-technology-works/> (26.02.08)
TrailerTrailers.com, RFID tags Overview,
<http://www.trailertrailers.com/RFID-tags.htm> (28.02.08)
RealTimeID.com, Technology,
<http://www.realtimeid.com/technology.htm> (27.02.08)
- [11] Dr. Paul Sanghera, Frank Thornton, Brad Haines, Anand M. Das, Hersh Bhargava, Anita Campbell
How to cheat at Deploying and Securing RFID
Syngress Publishing, Inc. 2007

- [12] IDzone, RFID til produktion og logistikk, <http://www.idzone.dk/> (10.03.08)
- [13] Intermec, <http://www.intermec.se> (10.03.08)
- [14] RFID Constructors, Hardware & knowledge, <http://www.rfidconstructors.com/> (10.03.08)
- [15] SuperRFid, <http://www.superrfid.net/> (10.03.08)
- [16] Motorola, Business products and services, <http://www.motorola.com/business/> (10.03.08)
- [17] Texas Instruments, TI-RFid, <http://www.ti.com/rfid/> (10.03.08)
- [18] Confidex, Master of Wireless identification, <http://www.confidex.fi/> (10.03.08)
- [19] Huayuan, <http://www.hy-smart.com/> (10.03.08)
- [20] Impinj, Impinj RFID, <http://www.impinj.com/rfid/> (10.03.08)
- [21] EPCglobal, Tag Class Definitions, http://www.epcglobalinc.org/standards/TagClassDefinitions_1_0-whitepaper-20071101.pdf (01.04.08)
- [22] Norwegian Post and Telecommunications Authority, http://www.npt.no/portal/page/portal/PAG_NPT_NO_NO/PAG_NPT_NO_HOME/PAG_NPT_NO_T_EKSTVISNING?p_d_i=-121&p_d_c=&p_d_v=105352 (10.03.2008)
- [23] Gao RFID Inc., Picture of a handheld RFID reader, <http://www.gaorfid.com/images/246001%20Portable%20reader%20Writer%20Gen2.jpg> (12.03.08)
- [24] Motorola, Picture of a stationary reader, http://www.motorola.com/staticfiles/Business/Products/RFID/RFID%20Readers/XR480%20RFID%20Reader%20for%20European%20deployments/Images/XR480BackRt_blue_259x259.jpg (12.03.08)
- [25] Gao RFID Inc., Understanding RFID, http://www.gaorfid.com/resources/rfid_understanding/ (03.04.08)
- [26] RFIDproductnews.com, Class 1 Generation 2, http://www.rfidproductnews.com/whitepapers/files/AT_wp_EPCGlobal_WEB.pdf (03.04.08)
- [27] InformIT.com, RFID: A Technology overview, <http://www.informit.com/articles/article.aspx?p=413662&seqNum=2> (01.04.08)
- [28] Air-Stream.org.au, Antenna Polarization, <http://www.air-stream.org.au/Polarization> (01.04.08)
- [29] RealTimeID.com, Solutions, <http://realtimeid.com/> (10.03.08)
- [30] TagsysRFID.com, Leader in item-level RFID systems, <http://www.tagsysrfid.com/> (10.03.08)

- [31] Wikipedia.org, Ionizing radiation, http://en.wikipedia.org/wiki/Ionizing_radiation (02.04.08)
- [32] Wikipedia.org, Non-ionizing radiation, http://en.wikipedia.org/wiki/Non-ionizing_radiation (02.04.08)
- [33] RFID4sme.eu, Is RFID safe at the work place?
<http://www.rfid4sme.eu/file.php?file=/Is%20RFID%20Safe%20At%20The%20Work%20Place.pdf&type=down> (02.04.08)
- [34] Wikipedia.org, Specific_absorption_rate, http://en.wikipedia.org/wiki/Specific_absorption_rate (02.04.08)
- [35] Darmindra D. Arumugam and Daniel W. Engels, Senior Member, IEEE
Specific Absorption Rates in Muscle Tissues for Passive UHF RFID Tag Backscatter
<http://students.uta.edu/dd/dda3192/Specific%20Absorption%20Rates%20in%20Muscle%20Tissues%20for%20Passive%20UHF%20RFID%20Tag%20Backscatter.pdf> (02.04.08)
- [36] World Health Organization (WHO), Electromagnetic fields (EMF),
<http://www.who.int/peh-emf/en/> (02.04.08)
- [37] Eva Zeizel, Robert Sabella
CompTIA RFID+
Que Publishing, 2006
- [38] Klaus Finkenzerler
RFID Handbook, Second Edition
Wiley, 2003

GLOSSARY & ABBREVIATIONS

Term	Explanation	URL
EPC	Electronic Product Code	http://www.epcglobalinc.org/
MIT	Massachusetts Institute of Technology	http://web.mit.edu/
EAN	European Article Number, EAN International changed its name to GS1	http://no.wikipedia.org/wiki/European_Article_Number
EAN.UCC	European Article Numbering-Uniform Code Council	http://en.wikipedia.org/wiki/European_Article_Numbering-Uniform_Code_Council
EIRP	Equivalent Isotropically Radiated Power	
ERP	Effective Radiated Power	
RFID	Radio Frequency Identification	
GS1	Standards Organization	http://www.gs1.no/
Transducer	Converts one form of energy into another form of output energy.	
LF	Low Frequency, 30 – 300kHz	
HF	High Frequency, 3-30MHz	
UHF	Ultra High Frequency, 300Mhz-3GHz	
MIT	Massachusetts Institute of Technology	http://web.mit.edu/
Auto ID Center	Research Lab at MIT, which was important in the development of EPC	http://www.autoidlabs.org/
Norwegian Post and Telecommunications Authority	Norwegian authority which regulates the frequencies and the sets the limits to how much an RFID system can emit of radiation.	http://www.npt.no/
SAR	Specific Absorption Rate	
FCC	Federal Communications Commission	http://www.fcc.gov/
WHO	World Health Organization	http://www.who.int/