

# Factors Constraining Students' Establishment of Algebraic Generality in Shape Patterns

A Case Study of Didactical Situations in Mathematics at a  
University College



Heidi Strømskag Måsøval

Factors Constraining Students' Establishment  
of Algebraic Generality in Shape Patterns

A Case Study of Didactical Situations in Mathematics at a  
University College

Doctoral Dissertation at the University of Agder

University of Agder  
Faculty of Engineering and Science  
2011

Doctoral Dissertations at the University of Agder 38

ISSN: 1504-9272

ISBN: 978-82-7117-699-0

© Heidi Strømskag Måsøval, 2011

Printed at the Printing Office, University of Agder  
Kristiansand, Norway

# Preface

This doctoral study was financed by Sør-Trøndelag University College, with funds from the Norwegian Ministry of Education and Research. I was awarded a four years doctoral scholarship for which I am most grateful. I am also grateful for the research resources provided by The Norwegian University of Technology and Science (NTNU) while employed there in the academic year 2009-2010. The Nordic Graduate School of Mathematics Education provided support which enabled me to attend several doctoral courses and a summer school; for this I am most thankful.

To my supervisors, Barbara Jaworski and Simon Goodchild, I want to express the deepest gratitude and thankfulness for sharing with me their knowledge and competence, and for all the encouragement and challenging comments. They have always been there for me, also in times of despair during my work, but never resorted to providing me with solutions. They have expected me to find my own way and demonstrated the confidence in my ability to do so. This has often made me feel that they have considered me their peer. Their attitude and involvement are greatly appreciated.

Next, I want to express my deep gratitude to the six student teachers and the two teacher educators who agreed to be research participants in my study. Without their willingness to put themselves on display, this research would have been impossible. Further, I want to thank researchers in mathematics education for their valuable help with the theories that underpin my study. These include Nicolas Balacheff, Guy Brousseau, Stephen Lerman, Marie-Jeanne Perrin-Glorian, and Carl Winsløw. Paul Ernest I want to thank for valuable comments on an earlier draft of this dissertation.

I also want to thank my colleagues at Sør-Trøndelag University College, and scientific staff and colleague doctoral students at The University of Agder, for their interest, support, and encouragement. Claire Berg and Arne Amdal I want to thank for translating texts from French into Norwegian, and Luc Trouche for translating between French and English e-mail communication I had with Professor Guy Brousseau. Virginia Warfield I want to thank for being an interpreter when I met Professor Brousseau at the Conference of the International Group for the Psychology of Mathematics Education, which took place in Prague 2006. Grete Espeland at Sør-Trøndelag University College library I want to thank for her enthusiasm and proficiency in providing me with the publications I needed.

Finally, I want to thank my family for their support, involvement, and patience during this doctoral work; my deepest thanks to Christian, Fay,

and Ole Steinar. We have come to share the attitude expressed by the philosophy teacher in Molière's play *Le Bourgeois Gentilhomme*:

*Sine doctrina vita est quasi mortis imago.*<sup>i</sup>

Heidi Strømskag Måsøval  
Trondheim, Norway  
September, 2011

<sup>i</sup> Without learning, life is but an image of death (Molière, 1670/1732, Act 2, Scene 4, p. 46).

# Abstract

In this dissertation I report from a study of teaching-learning situations that deal with algebraic generalisation of shape patterns. The focus is on factors that constrain students' establishment and justification of formulae and mathematical statements that represent generality in different shape patterns. Participants in the study are six student teachers and two teacher educators in mathematics at the programme "Teacher education with emphasis on mathematics and science subjects" at a University College in Norway.<sup>1</sup>

I have used Guy Brousseau's (1997) theory of didactical situations in mathematics to analyse the empirical material which consists of classroom observations and the mathematical tasks with which the students engaged. Brousseau's theory is a scientific approach to the problems posed by the teaching and learning of mathematics, where the particularity of the knowledge taught is in focus and plays a significant role. I wanted to find out what factors constrain students' algebraic generalisation processes by exploring relationships between three "instances": the target mathematical knowledge; the teaching-learning situations in which the students engaged collaboratively; and, the outcome of the students' engagement in those situations. I have augmented the theory of didactical situations in mathematics by Lev Vygotsky's (1934/1987) theory of concept development.

Methodologically, I interpret my study to be an educational case study (Stenhouse, 1988) within a qualitative research paradigm (Denzin & Lincoln, 2005). There are two cases, each of which consists of a group of three students (with teacher involvement). The cases are instrumental to the understanding of students' algebraic generalisation of shape patterns. In my investigation of factors that constrain students' algebraic generalisation processes, I define the small-group teaching situation as the unit of analysis when I examine how the didactical "milieu" constrains the opportunities for the students to appropriate the target mathematical knowledge. The milieu is the subset of the students' environment with only those features that are relevant with respect to the target knowledge.

---

<sup>1</sup> In the rest of the abstract, "students" is used to refer to student teachers, and "teacher" is used to refer to a teacher educator.

The analytic findings indicate that the students' algebraic generalisation processes are constrained in three senses. The first constraint is related to a limited feedback potential in situations where the students are supposed to solve the mathematical tasks without teacher intervention. This constraint is materialised in terms of three phenomena: adaptedness of design of mathematical tasks; clarity of concepts; and, institutionalisation of previous knowledge. The second constraint is related to obstacles the students face when they shall transform into algebraic notation formulae and mathematical statements they have expressed informally in natural language. This constraint is materialised in terms of two phenomena: distinctiveness of recursive and explicit approaches to generality in shape patterns; and, the syntax of algebra. The third constraint is related to challenges with justification of formulae and mathematical statements that the students have proposed. This constraint is materialised in terms of two phenomena: pertinence of concepts (spontaneous versus scientific concepts); and, validity of reasoning (empirical reasoning versus formal, rigorous mathematical reasoning).

Overall, the dissertation contributes to a better understanding of factors that are important in the design and implementation of teaching-learning situations aiming at algebraic generalisation of shape patterns. This includes insights into necessary features of the milieu.



# Sammendrag

I denne avhandlingen rapporterer jeg fra en studie av undervisnings- og lærings situasjoner knyttet til algebraisk generalisering av figurmønstre. Fokuset er på faktorer som begrenser studenters etablering av og bevis for formler og matematiske setninger som representerer generaliteter i ulike figurmønstre. Deltakere i studien er seks lærerstudenter og to lærerutdannere i matematikk i programmet “Allmennlærer med vekt på realfag” ved en høyskole.<sup>2</sup>

Jeg har benyttet Guy Brousseaus (1997) teori for didaktiske situasjoner i matematikk i analysen av det empiriske materialet, som består av klasseromsobservasjoner og matematikkoppgaver som studentene arbeidet med. Brousseaus teori er en vitenskapelig tilnærming til spørsmål knyttet til undervisning og læring av matematikk, der særegenhetene til målkunnskapen spiller en avgjørende rolle. Jeg ønsket å finne ut hvilke faktorer som begrenser studenters algebraiske generaliseringsprosesser gjennom å utforske relasjoner mellom tre “instanser”: den definerte, matematiske målkunnskapen; undervisnings- og lærings situasjoner der studenter samarbeider om å løse matematikkoppgaver; og, resultatet av studentenes arbeid med matematikkoppgavene. Jeg har utvidet teorien for didaktiske situasjoner i matematikk med Lev Vygotskys (1934/1987) teori for begrepsutvikling.

Fra et metodologisk synspunkt ser jeg min studie som en utdanningscasestudie (Stenhouse, 1988) innenfor et kvalitativt forskningsparadigme (Denzin & Lincoln, 2005). Studien består av to case der hver case utgjøres av en gruppe med tre studenter (i samhandling med matematikklæreren). Casene er instrumenter for forståelsen av studenters algebraiske generalisering av figurmønstre. I min utforskning av faktorer som begrenser studenters algebraiske generaliseringsprosesser defineres undervisningssituasjonen knyttet til smågruppen som analyseenheten der jeg undersøker hvordan det didaktiske “miljøet” begrenser studenters muligheter for å appropriere den definerte målkunnskapen. Miljøet er den delmengden av studentenes omgivelser som er relevant kun i forhold til den matematiske målkunnskapen.

---

<sup>2</sup> I resten av sammendraget vil “studenter” referere til lærerstudenter og “lærer” vil referere til en lærerutdanner.

De analytiske funnene indikerer at studentenes algebraiske generaliseringsprosesser er begrenset på tre måter. Den første begrensningen er relatert til et begrenset feedbackpotensial i situasjoner der studentene er forventet å løse matematikkoppgaver uten lærerintervensjon. Denne begrensningen er materialisert gjennom tre fenomener: tilpasningen av matematikkoppgavens design; begreper klarhet; og, institusjonaliseringen av tidligere kunnskap. Den andre begrensningen er relatert til transformasjonen fra naturlig språk til algebraisk notasjon av sammenhenger studentene har identifisert i figurmønstre. Denne begrensningen er materialisert gjennom to fenomener: særegenheten til rekursive og eksplisitte tilnærminger til algebraisk generalitet i figurmønstre; og, algebraisk syntaks. Den tredje begrensningen er relatert til argumentasjon og bevis for gyldigheten av de formlene og matematiske setningene som studentene utvikler. Denne begrensningen er materialisert gjennom to fenomener: relevansen av begreper (spontane versus vitenskapelige begreper); og, gyldigheten av resonnementer (empirisk resonnement versus stringent matematisk resonnement).

Mer overordnet bidrar avhandlingen til en bedre forståelse av faktorer som er viktige med tanke på design og implementering av undervisningssituasjoner rettet mot algebraisk generalisering av figurmønstre. Dette inkluderer innsikt i nødvendige egenskaper ved miljøet.

# Contents

1	Introduction	17
1.1	The relevance of algebra	17
1.2	My professional background and research focus	19
1.3	The theoretical framework that guided the research	21
1.4	The research setting and methods adopted	22
1.5	The structure of the dissertation	23
2	Theoretical framework	25
2.1	Introduction to Brousseau's theory of didactical situations in mathematics	26
2.2	A scientific approach to the set of problems posed by the teaching and learning of mathematical knowledge	32
2.2.1	A theory about a triadic didactical relationship	32
2.2.2	Learning, teaching, and knowledge in the framework of didactical situations	34
2.3	Didactical phenomena connected with control of the didactical transposition	35
2.3.1	The Topaze effect	37
2.3.2	The Jourdain effect	38
2.3.3	The improper use of analogy	39
2.3.4	The metacognitive shift	39
2.3.5	The metamathematical shift	41
2.3.6	The Diénès effect	42
2.3.7	The aging of teaching situations	45
2.4	Modelling of teaching situations	46
2.4.1	Devolution, adidactical situations, and didactical situations	46
2.4.2	The didactical contract	48
2.4.3	Different types of didactical situations	50
2.4.4	The milieu	55

2.5	Legitimacy of the theory of didactical situations in this study	63
2.6	Vygotsky's theoretical approach	67
2.6.1	Mediation	68
2.6.2	Instruction and development of scientific concepts	70
2.7	Compatibility of Brousseau's theory and Vygotsky's theory	72
2.7.1	Starting within a constructivist frame	73
2.7.2	Studying relationships between experiments on children's cognitive development and particular pieces of knowledge	73
2.8	Summary	79
3	Theoretical foundation for a pattern based approach to algebra	81
3.1	A content analysis of "algebra"	81
3.2	Two approaches to school algebra: Pattern generalisation versus problem solving	83
3.3	Algebra introduced through generalisation of patterns	86
3.3.1	Abstraction and expression of generality	86
3.3.2	Algebraic thinking	88
3.4	Literature summary of reports from empirical studies of students' pattern generalisation	91
3.5	Promoting students' algebraic thinking	97
3.6	The teacher's role in students' algebra learning	100
3.7	Relevance of research on students' generalisation of patterns for this research inquiry	101
4	Methodology	105
4.1	Ontological and epistemological assumptions	106
4.1.1	Ontology of the social reality studied	106
4.1.2	Epistemology of the social reality studied	108
4.2	An idiographic research methodology	110
4.3	The context of the study	112
4.3.1	The teacher education programme	112

4.3.2	The mathematics course	114
4.3.3	Student teacher participants	116
4.3.4	Mathematics teacher participants and organisation of the mathematics teaching	117
4.4	Research methods	119
4.4.1	Style of inquiry	119
4.4.2	Selection of site and research participants	120
4.4.3	Data sources and instruments used to collect data	123
4.4.4	My own role during data collection	124
4.4.5	Unit of analysis	125
4.4.6	Methods for analysis of data	126
4.4.7	Ethical issues	132
5	Epistemological and didactical analyses of the mathematics potential in tasks on algebraic generalisation of shape patterns	139
5.1	Epistemological analysis	139
5.1.1	Sequences and shape patterns	139
5.1.2	Arithmetic relations	140
5.1.3	Generalisation in terms of two different types of mathematical objects	141
5.1.4	Formulae for the general member of a sequence	143
5.1.5	Mathematical statements	145
5.1.6	Growth of sequences	146
5.2	Didactical analysis	147
5.2.1	Different approaches to and different modes of reasoning about algebraic generality in shape patterns	147
5.2.2	Exemplification of different modes of reasoning towards an explicit formula for the $n$ -th member of a sequence mapped from a shape pattern	151
5.2.3	The value of algebraic generalisation of shape patterns with respect to mathematical learning	153
6	Constrained feedback potential in <i>adidactical</i> situations	157

6.1	Features of the objective milieu arising from the design of the tasks	157
6.1.1	Adequate solutions to subtasks do not prepare an adequate milieu for the (teacher's) intended mathematical statement	157
6.1.2	The idea of proof as intended in Task 3 is not apparent for the students	160
6.2	Features of the milieu arising from lacking clarification of the concepts of "mathematical statement" and "generic example"	168
6.2.1	Establishment of a formula for the numerical value of an element instead of a theorem about equivalence of two expressions	169
6.2.2	A generic example for the teacher but not for the students	174
6.2.3	Topaze effects resulting from students' production of an unintended mathematical object	18174
6.3	Features of the milieu arising from incomplete institutionalisation of previous knowledge	184
6.3.1	Non-reusability of knowledge originated by Topaze effects	184
6.3.2	A "malformula" resulting from incomplete institutionalisation of syntax of recursive formulae	186
6.3.3	Teacher's assumption about students' outcome from a previous lesson does not accord with achieved outcome	190
6.4	Summary	194
6.5	Discussion of the first analytic category	196
6.5.1	Design of tasks	196
6.5.2	Different target mathematical objects	197
6.5.3	Institutionalisation	199
7	Complexity of turning a situation of action into a situation of formulation	201
7.1	Recursive and explicit approaches to the general member of a sequence	201

7.1.1	Overgeneralisation of a recursive approach to an explicit approach to generality and an incidence of a metamathematical shift	201
7.1.2	A Jourdain effect resulting from an attempt to establish a functional relationship	208
7.1.3	Acceptance of an incomprehensible difference	211
7.1.4	Students' recursive approach to generality unmarked by the teacher	215
7.1.5	Complexity of transforming recursively expressed properties into an explicit algebraic expression	218
7.2	The syntax of algebra	222
7.2.1	Identification of need for knowledge of arithmetic series	222
7.2.2	Disregard of a presented formula associated with limited knowledge of syntax of formulae	226
7.2.3	Complicated symbolisation of relations between natural numbers, odd numbers and square numbers	229
7.3	Summary	232
7.4	Discussion of the second analytic category	234
7.4.1	Recursive versus explicit approaches to algebraic generality in shape patterns	235
7.4.2	Algebraic symbolisation of generality in shape patterns	236
8	Complexity of operating in the situation of validation	239
8.1	Pertinence of concepts (spontaneous versus scientific concepts)	239
8.1.1	Explaining what is meant by "structure" and "structural relationship"	240
8.2	Distinction between empirical reasoning and formal, rigorous mathematical reasoning	245
8.2.1	Unawareness of the importance of how a formula is derived	246
8.2.2	Explaining the disparity between two equivalent formulae	248
8.3	Summary	252

8.4	Discussion of the third analytic category	253
8.4.1	An attitude of proof	253
8.4.2	Validity of reasoning	255
9	Synthesis	257
9.1	Relationships between categories, and dimensions of subcategories	257
9.2	Complexity of developing the scientific concept “mathematical statement”	264
9.2.1	Formulation of a mathematical statement constrained by features of the milieu	265
9.2.2	Complexity of transforming experiences with invariant structures expressed in everyday concepts into the scientific concept of a mathematical statement	266
9.2.3	Complexity of mediating the idea of (and need for) mathematical proof	267
9.3	Degenerated situation of institutionalisation	268
9.4	Strengths and limitations of the reported research	269
9.4.1	Credibility	270
9.4.2	Transferability	272
9.4.3	Dependability	273
9.4.4	Confirmability	273
9.5	Potential pedagogical implications	274
9.6	Closing remark	277
10	References	279
11	Appendices	301



# 1 Introduction

This dissertation is about first-year student teacher's collaborative endeavour to express and justify algebraic generality in shape patterns at a university college in Norway. The focus is on factors that constrain student teachers' appropriation of algebraic generality in shape patterns. The dissertation provides insights into the relationship between three factors: the design of mathematical tasks and the teaching approaches used; the student teachers' engagement with the tasks; and, the target mathematical knowledge.

In this introductory chapter I provide a rationale for the choice of algebra as the mathematical focus of my research (Section 1.1). Next follows a presentation of who I am and why I have undertaken this research (Section 1.2). Next follows a brief sketch of the theoretical framework that guided the research (Section 1.3). Then the research setting and methods employed are briefly introduced (Section 1.4), before the chapter closes with an overview of the rest of the dissertation (Section 1.5).

## 1.1 The relevance of algebra

Inspired by the writing of Alfred N. Whitehead (1947), Godfrey H. Hardy (1940/1992), Michael D. Resnik (1981), Keith Devlin (1994), and others, I view mathematics as the science of patterns. Resnik theorises patterns by suggesting that infinite patterns are infinite extensions of finite patterns. In his proposal he observes that

a pattern is a complex entity consisting of one or more objects, which I call positions, standing in various relationships (and having various characteristics, distinguished positions and operations). . . . Patterns are related to each other by being congruent or structurally isomorphic. Congruence is an equivalence relation whose field I take to include both abstract structures and arrangements of concrete objects. (Resnik, 1981, pp. 531-532)

Resnik (1981) claims that patterns can be referred to in different modes and he mentions three possible ways of denotation: One way is by stating how many positions a pattern has and how they are related. A second way is by presenting an instance of a pattern and add that the pattern *instantiated* is the pattern one has in mind.<sup>3</sup> A third way is by introducing

---

<sup>3</sup> When a pattern and an arrangement of so-called concrete objects (e.g., an alignment of geometric configurations) are congruent, the arrangement is said to *instantiate* the pattern (Resnik, 1981).

labels for positions and stating how the positions are related in terms of these (Resnik, 1981).

A shape pattern in school mathematics is usually instantiated by some consecutive geometric configurations in an alignment imagined as continuing until infinity, a denotation in line with Resnik's (1981) second category presented above. Luis Radford (2006) characterises *algebraic generalisation* of patterns when he proposes that

generalizing a pattern algebraically rests on the capability of grasping a commonality noticed on some elements of a sequence  $S$ , being aware that this commonality applies to all the terms of  $S$  and being able to use it to provide a direct expression of whatsoever term of  $S$ . (Radford, 2006, p. 5)

This means that the algebraic generalisation of a pattern rests on noticing a local commonality that is then generalised to all members of the infinite sequence mapped from the pattern (beyond the perceptual field). A closer examination of the concepts of shape pattern and algebraic generalisation will be given in Chapter 5, where I present epistemological and didactical analyses of the mathematics potential in tasks on algebraic generalisation of shape patterns.

*Algebra* is the language in which generalisation of quantity and relationships of patterns can be expressed, manipulated, and reasoned about (Whitehead, 1947; see also, Kieran, 2004). When John Mason (1996) claims that the heart of teaching mathematics is the awakening of pupils' sensitivity to the nature of mathematical generalisation and dually, to specialisation, he points at the important role algebra plays in school mathematics. Students, however, experience serious difficulties in learning the symbolic language of algebra and algebraic thinking. This is well documented in the research literature (e.g., Bishop & Stump, 2000; Herscovics & Linchevski, 1994; Kieran, 1992; Lannin, Barker, & Townsend, 2006; Linchevski & Herscovics, 1996; MacGregor & Stacey, 1995; Redden, 1996; Sfard, 1991; Stacey, 1989; Stacey & MacGregor, 2001; Warren, 2005).

In the prevailing mathematics subject curriculum in Norway (Directorate for Education and Training, 2006), *Numbers and algebra* is one of four main subject areas from Year 5 through Year 7 (the other subject areas are *Geometry*; *Measuring*; and, *Statistics and probability*), and one of five main subject areas from Year 8 through Year 10 (the other subject areas are *Geometry*; *Measuring*; *Statistics, probability, and combinatorics*; and, *Functions*). Previous curricula for school mathematics in Norway introduced algebra in later years. For example, during the period 1997-2006, algebra was introduced from Year 7 (Ministry of Education, Research, and Church Affairs, 1996). The reason for implementing algebra earlier, I interpret to be a desire to identify algebra with algebraic thinking, rather than with the structural features that has usually identi-

fied school algebra. David Kirshner (2001) proceeds to argue that algebra in school has been (and continues to be) to a great extent about manipulation of formalisms. The important role of algebra in school mathematics is reflected in the local framework for the compulsory mathematics course in the teacher education programme where I conducted my research (The Faculty Board, 2003). I will come back to this framework in Section 4.3, where I present the context of the study.

Algebra as generalisation of patterns is part of the elementary and secondary curriculum in many countries, for example England (Department for Education and Employment, 1999); the United States (National Council of Teachers of Mathematics, 2000); Australia (Queensland Studies Authority, 2004); Canada (Ontario Ministry of Education and Training, 2005); and, Norway (Directorate for Education and Training, 2006). From a mathematical perspective, spatial and numerical patterns offer a powerful context for learning about dependent variation where students engage in formulation of functional relationships. Several studies have, however, documented students' difficulties in establishing algebraic formulae from patterns and tables (e.g., MacGregor & Stacey, 1992, 1993; Lannin et al., 2006; Orton & Orton, 1996; Stacey, 1989; Warren, Cooper, & Lamb, 2006). I will come back to these findings in Chapter 3 where I include a summary overview of reports from empirical studies in which a pattern-based approach to algebra is used (Section 3.4).

In the next section I present a brief autobiography and the research focus, and explain why I have undertaken the research reported in this dissertation.

## **1.2 My professional background and research focus**

The research reported in this dissertation has focused on student teachers and mathematics teacher educators within a four-year undergraduate teacher education programme for primary and lower secondary education. At the time I started the research project reported here, I had been a mathematics teacher in upper secondary school for four years and then a teacher educator in mathematics for six years. Simultaneously while conducting the research project, I have been involved in development and implementation of a master's programme in mathematics education.

My formal education includes a master's degree in pure mathematics (algebra),<sup>4</sup> and pedagogical education.<sup>5</sup>

During the years I have served as a mathematics teacher and mathematics teacher educator, I have experienced that algebra is a topic that many students and student teachers conceive of as difficult to understand. This experience, together with the relevance of algebra and the evidence of students' difficulties in learning algebra referred to in Section 1.1, triggered me to learn more about teaching and learning of algebra. I presumed that being more knowledgeable in the field would make me a better teacher and enable me to better facilitate students' learning of algebra. I wanted to develop knowledge about the nature of the complexity of student teachers' algebraic generalisation processes. More precisely, I wanted to get insights into how design of tasks and teaching approaches used has an impact on the knowledge developed by students while working collaboratively on algebraic generalisation of shape patterns. The research question which I set out to address was: *What factors constrain students' appropriation of algebraic generality in shape patterns?*

Research on students' processes of pattern generalisation suggests that it is not generalisation tasks in themselves that are difficult, but rather the way they are designed and the limitations of the teaching approaches employed (Lee, 1996; Moss & Beatty, 2006; Noss, Healy, & Hoyles, 1997; Stacey & MacGregor, 2001). Relationships between the design of tasks and teaching approaches used on the one hand, and students' difficulties on the other, will be addressed by the research reported in this dissertation. An argument for the significance of conducting systematic inquiry into teacher educators' practice of preparing teachers for teaching algebra is offered by Helen M. Doerr (2004). She claims that this type of inquiry has been only occasional, and that further research is important for developing a professional knowledge base for teaching algebra:

While we know that traditional mathematics courses alone will not be sufficient in preparing teachers' understanding of school algebra, the practical knowledge of teacher educators in preparing teachers has only sporadically contributed to

---

<sup>4</sup> In Norwegian, "hovedfag" (achieved 1994).

<sup>5</sup> My pedagogical education is equivalent to the Postgraduate Certificate in Education (PGCE) offered in the United Kingdom.

the building of a professional knowledge base for teaching in ways that are able to be shared, generalised, and reused by others in the field. (Doerr, 2004, p. 285)

In the next section I present a brief introduction to the theories that underpinned the research (an elaborated version will be given in Chapter 2).

### **1.3 The theoretical framework that guided the research**

I situate my research within the French *didactique*. The field of research of didactique can be understood as the study of the transformations of mathematical knowledge under the conditions and constraints of the social project of education (Herbst & Kilpatrick, 1999). I have used Guy Brousseau's (1997) theory of didactical situations in mathematics to analyse the empirical material. Brousseau's theory is a scientific approach to the problems posed by the teaching and learning of mathematics, where the particularity of the knowledge taught is engaged and plays a significant role (Brousseau, 2000).<sup>6</sup> I wanted to find out what factors constrain students' algebraic generalisation processes by exploring relationships between, on the one hand, the teaching-learning situations in which the participants of the study engaged, and, on the other hand, the target mathematical knowledge defined by the teacher who had designed the situations. Brousseau's theory is relevant as a framework in this respect because the theory is about a triadic didactic relationship; the interplay between the teacher, the student (or rather, a group of students), and some particular mathematical knowledge.

The framework I have used as a grand theory (Carr & Kemmis, 1986) to conceptualise cognition and learning is sociocultural theory as outlined by Lev S. Vygotsky (1978, 1981a, 1981b, 1934/1987) and his successors. There are three fundamental concepts in Vygotsky's explanation of learning and development as mediated processes (Daniels, 2007). First, the general genetic law of cultural development (Vygotsky, 1981b); second, the zone of proximal development (Vygotsky, 1978); and third, concept formation as an outcome of the interplay between spontaneous and scientific concepts (Vygotsky, 1934/1987). Vygotsky's

---

<sup>6</sup> Quotations from Brousseau (2000) are translated by Virginia Warfield. Translation is retrieved from [http://www.math.washington.edu/~warfield/Ed\\_and\\_Didact.html](http://www.math.washington.edu/~warfield/Ed_and_Didact.html). Page numbers refer to the original publication in French.

principle of scientific concepts as the content of school instruction is an elaboration of Vygotsky's general theoretical view of mediated learning as the major determinant of human development (Kozulin, 2003).

The theoretical framework that guided the research is presented in Chapter 2, where I explain and exemplify fundamental concepts. The chapter also includes an argument for the legitimacy of Brousseau's framework in the research reported here. Further (in Chapter 2), I argue that Brousseau's theory is compatible with socio-cultural theory as outlined by Vygotsky and his successors.

In the next section I present a brief sketch of the context of the study and the methods adopted.

#### **1.4 The research setting and methods adopted**

The research reported in this dissertation has been conducted within a four-year undergraduate teacher education programme for primary and lower secondary education at a university college in Norway. The students who participated in the research were enrolled on a programme referred to as *Teacher education with emphasis on mathematics and science subjects* (Ministry of Education and Research, 2003). The teacher educators who participated in the research were experienced teacher educators of mathematics.

I have chosen a collective case study (Stake, 1995) as style of inquiry, where each of the two cases is a group of three students. The unit of analysis is defined as the teaching-learning situation in which the groups take part. In Chapter 4 I will explain further the unit of analysis, after I have presented necessary concepts in Chapter 2, on which it draws. There are two main sources of data: the video recorded observations of the students' collaborative engagement with mathematical tasks on algebraic generalisation of shape patterns; and, the mathematical tasks with which the students engaged.

I consider a teaching-learning situation in mathematics as a social entity which is realised through its social participants; the teacher and the students actively construct the didactical situation with its potentialities and constraints. I assumed that knowledge of factors that constrain students' algebraic generalisation of shape patterns could be exposed as interpretations of relationships between the students, the teacher, and the mathematical knowledge at stake. How the ontological and epistemological assumptions expressed in the above called for an idiographic research methodology (Burrell & Morgan, 1979) is explained in Chapter 4, where I provide a rationale for situating my study within a qualitative, interpretative paradigm and choosing an *educational* case study as style of inquiry.

An inductive approach has been used to analyse the classroom dialogues. The analysis involved coding of data, and drew on the epistemological and didactical analyses of the mathematics potential in the tasks. Three analytic categories emerged from the data analysis. They are conceptualisations of factors that constrain students' algebraic generalisation of shape patterns. The constraints are interpreted as properties of the teaching-learning situation which are identified in the relationships between the teacher, the students, and the target mathematical knowledge.

In the next section I present an overview of the rest of the dissertation.

## **1.5 The structure of the dissertation**

Following this introductory chapter, I present in Chapter 2 the theoretical framework that guided the research. Then follows in Chapter 3 a theoretical foundation for algebra as generalisation of patterns, including a summary overview of reports from empirical studies in which a pattern-based approach to algebra is employed. The research methodology is presented in Chapter 4, including a presentation of the context of the study. Chapter 5 is a presentation of the epistemological and didactical analyses of the mathematics potential in the tasks with which the observed students engaged. Chapter 6 presents the first of three analytic categories that emerged from the exploration of the empirical material, conceptualised as *Constrained feedback potential in didactical situations*. Chapter 7 presents the second analytic category, conceptualised as *Complexity of turning a situation of action into a situation of formulation*. Chapter 8 presents the third analytic category, conceptualised as *Complexity of operating in the situation of validation*. The dissertation closes in Chapter 9 with a synthesis of the findings, including a discussion of strengths and limitations of the research I have undertaken, and reflections on potential pedagogical implications of the reported research.

In the next chapter I present the theoretical framework that guided the research.





## 2 Theoretical framework

In analysing factors that constrain students’<sup>7</sup> establishment of algebraic generality in shape patterns, I was interested in how teaching-learning situations have an impact on the knowledge developed by students when they work collaboratively on mathematical tasks. More precisely, I have studied the relationships between three components: the knowledge to be taught and learned; the mathematical tasks and the teaching approach used; and, the interactions between the students and the *milieu*<sup>8</sup> during their engagement with the tasks. The theoretical framework I have used to do this is Brousseau’s theory of didactical situations in mathematics (Brousseau, 1997), which will be presented in this chapter. The framework I have used as a *grand theory*<sup>9</sup> (Carr & Kemmis, 1986) to conceptualise cognition and learning is sociocultural theory as outlined by Vygotsky and his successors.

In Section 2.1 a characteristic of *didactique* and an introduction to the theory of didactical situations are presented. An account of the theory as a scientific approach to the problems posed by the teaching and learning of mathematics is presented in Section 2.2, where the concepts of learning, teaching, and knowledge are defined. Section 2.3 presents phenomena of didactique conceptualised as didactical effects connected with control of the transformation of mathematical knowledge to the classroom context. Section 2.4 presents Brousseau’s (1997) model of teaching situations, where the concepts, “devolution”, “adidactical situations”, “didactical situations”, “didactical contract”, and “milieu” are introduced. In Section 2.5 I argue for the relevance of the theory of didactical situations in my study.

Vygotsky’s theoretical approach is presented in Section 2.6 where the focus is on the notions of mediation and scientific concepts. These notions are used in a conceptualisation of didactical situations in mathemat-

---

<sup>7</sup> In the rest of the dissertation, “students” is used to refer to student teachers, and “teacher” is used to refer to a teacher educator.

<sup>8</sup> “Milieu” as used here refers to the subset of the students’ environment with those features only which are relevant with respect to the target mathematical knowledge. The concept will be further explained in Section 2.4.4.

<sup>9</sup> Wilfred Carr and Stephen Kemmis (1986) define a *grand theory* as a theory “that has a consciousness of the need to place education as a process of ‘coming to know’ in the context of general theory of society on the one hand and a theory of the child on the other” (p. 11).

ics as mediating between the students and some particular mathematical knowledge. In Section 2.7 I argue that Brousseau's theory is compatible with sociocultural theory. Section 2.8 closes the chapter with a brief summary of the presented theoretical framework.

## 2.1 Introduction to Brousseau's theory of didactical situations in mathematics

The object of study of didactique is the relationships between three components: the mathematical knowledge to be taught and learned; the knowings that emerge in the interactions between the students and the milieu; and, the educational project that binds teacher and students into a relationship which requires the reproduction of cultural knowledge and simultaneously the production of meaningful knowings compatible with that knowledge (Herbst & Kilpatrick, 1999). Didactique can therefore be understood as the study of the transformations of mathematical knowledge under the conditions and constraints of the social project of education. As expressed by Brousseau (1997):

The agreed effort of obtaining knowledge independently of the situations in which it is effective (decontextualization) has as a price the loss of meaning and performance at the time of teaching. The restoration of intelligible situations (recontextualisation) has as a price the shift of meaning (didactical transposition)<sup>10</sup>. The retransformation of the student's knowledge or of cultural knowledge takes up the process again and heightens the risk of side-slip. Didactique is the means of managing these transformations, and first, of understanding their laws. (p. 262)

Brousseau (1994, as cited in Sierpinska, 1995)<sup>11</sup> claims that research in didactics<sup>12</sup> of mathematics will consist of three fundamental constituents: application of research methods and theoretical concepts from other

---

<sup>10</sup> The concept of *didactical transposition* refers to the process of transformation of mathematical knowledge to the classroom context. It will be explained in more detail in Section 2.2.1.

<sup>11</sup> Brousseau, G. (1994). Problems and results of didactique of mathematics. Paper presented at the ICMI Study Conference, *What is research in mathematics education and what are its results?* University of Maryland, College Park, MD.

<sup>12</sup> I will use the word "didactics" in this dissertation to designate in English what the same noun usually means in German (Didaktik), French (didactique), Norwegian (didaktikk), and so forth. Briefly, I mean by didactics the study of the teaching and learning of knowledge within a disciplinary domain. This practice is in line with Yves Chevallard (1999), who discusses the advantages of using the word didactics also in English.

disciplines; didactique; and, didactical engineering. He explains what the three constituents are:

- the research in mathematics teaching stemming from the application of methods or concepts from other disciplines (psychology, sociology, linguistics, education, etc.) and/or those that are not specific to mathematics;
- the didactique of mathematics that endeavors to identify and explain didactic phenomena specific to mathematics and allows [the researcher] to apply the results of other disciplines;
- the didactic engineering that endeavors to produce the means and teaching materials based more or less on didactique and other disciplines. (Brousseau, 1994, as cited in Sierpinska, 1995, pp. 178-179)

The three constituents defined in the quotation provide insights into the nature of knowledge in didactics of mathematics (the outcome of research in the field) and aim to explain the distinction between didactique and didactical engineering, as conceptualised by Brousseau. It is relevant to give a further explanation of the concept of *didactical engineering*, of *what* is engineered. According to Patricio Herbst and Jeremy Kilpatrick (1999), didactique's focus on knowledge (rather than on learning) qualifies one to speak about engineering only of the situations in which an item of mathematical knowledge is at stake rather than the psychological development of the students. Didactical engineering deals with the production of the possible or obtainable meanings of a student's engagement. That is, it is about the design (relative to some target knowledge) of an actual *opportunity* for a student to learn rather than the actual learning. Essentially, engineering in the context of didactique is not about engineering learners (Herbst & Kilpatrick, 1999; see also, Artigue & Perin-Glorian, 1991). Didactical engineering is the practice of producing the means and teaching materials based on knowledge of the transposition of mathematical knowledge for teaching.

According to Michèle Artigue (1994), the theory of didactical situations in mathematics is a system of models and concepts that aims to model teaching situations so that they can be developed in a controlled way. "The aim is to develop the conceptual and methodological means to control the interacting phenomena and their relation to the construction and functioning of mathematical knowledge in the student" (Artigue, 1994, p. 29). This entails an epistemological analysis, the importance of which Brousseau (1997) emphasises when he writes:

The creation and management of teaching situations are not reducible to an art which the teacher can develop spontaneously by means of good attitudes (listen to the child), around simple techniques (the use of games, material, or cognitive conflict, for example). Didactique is not reduced to a technology, and its theory is not that of learning but that of the organisation of other people's learning, or more generally, that of dissemination and transposition of knowledge. (p. 244)

In claiming that a teaching situation is not reducible to an art which can be developed spontaneously, Brousseau refers to the importance of the teacher doing an *a priori* analysis of the target knowledge. He, further, argues that “it is indispensable [for the teacher or researcher] to create conditions that probably won’t occur naturally, in order to study them. A system delivers more information when it reacts to well chosen stimulation” (Brousseau, 1999, p. 40).

The theory of didactical situations proposes a methodology that starts by questioning mathematical knowledge as it is implicitly assumed in educational institutions: What is counting? What is algebra? What are decimal numbers? and so forth (Bosch, Chevallard, & Gascón, 2005). Brousseau’s theory has been described as an *epistemological programme* to didactique, focused on epistemological and didactical analyses of mathematical knowledge, where the students’ mathematical activity is the primary object of investigation (Gascón, 2003). The fundamental methodological principle of the theory is expressed by Marianna Bosch, Yves Chevallard, and Joseph Gascón (2005) to be that a piece of mathematical knowledge is represented by an epistemological model – a *situation* – which involves mathematical problems that can be solved in an optimal manner using the knowledge aimed at: “A mathematical concept can only be analysed [by the teacher or researcher] as far as it appears as a solution to a situation” (p. 1255). An epistemological model is a model of two things: first, of some target knowledge; second, of a process by which the target knowledge is learned by the student. An example of an epistemological model is provided by Heinz Steinbring (1997, 1998), where he describes the concept of an *epistemological triangle*. He explains that

the epistemological triangle is a means to characterize specific epistemological aspects of mathematical knowledge codified by signs and symbols, and at the same time this triangle can be used as a methodical instrument to analyze the constitution of mathematical meaning by interpreting signs in social processes of mathematical communication. (Steinbring, 1998, p. 172)

I illustrate the idea of an epistemological model in the following paragraphs, using an example of an epistemological model for the study of similarity, which is adapted from Brousseau (1997).

The knowledge the students are intended to learn is the principle that *similarity is a multiplicative structure*; this is the target knowledge. A model of the target knowledge is created using the dissections of two squares into polygons as shown in Figure 2.1 (on the next page). Corresponding polygons in the two squares are constructed such that corresponding angles are equal and side lengths are changed in the same ratio; that is, they are similar figures. Next, the “imagined trajectory” of students’ engagement with the task of enlargement of a shape into a similar

shape is the model of the cognitive impact that the task is supposed to achieve. It models the presumed events in the learners' process of coming to know that similarity is based on the side lengths of the original shape being multiplied by a fixed factor (the scale, or ratio of magnification). This operation, characteristic for a linear mapping, is the solution to the task of enlargement of a shape. I will now describe briefly how students' engagement in the lesson might proceed.

The teacher presents to the students the square in Figure 2.2, which she refers to as a puzzle which they are supposed to enlarge into a similar puzzle according to the following rule: The line segments that measure 5 cm on the given puzzle will measure 8 cm on the enlarged puzzle.

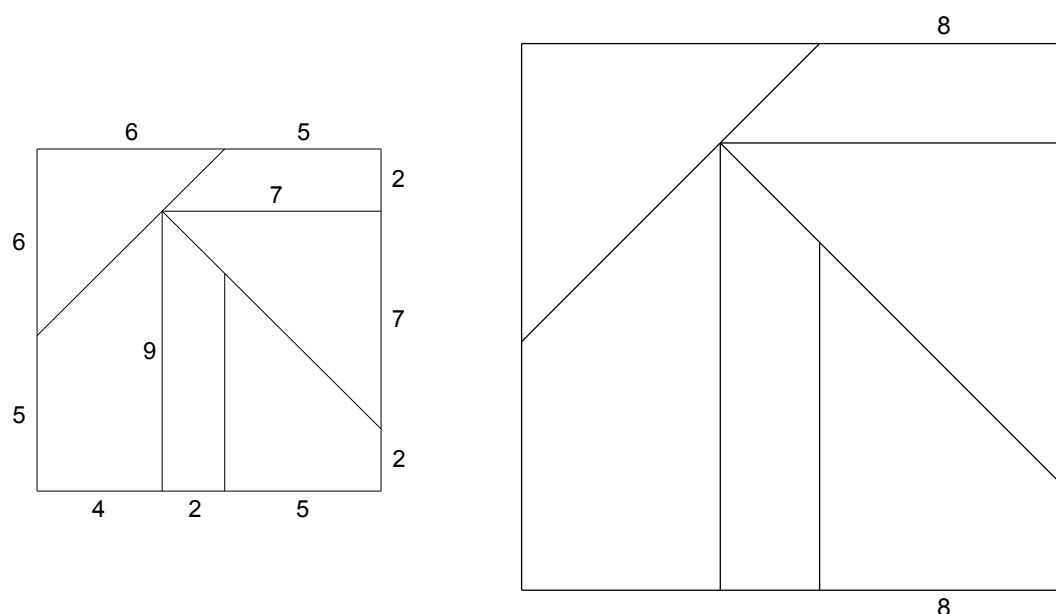

Figure 2.1. Model of the target knowledge, that “similarity is a multiplicative structure”

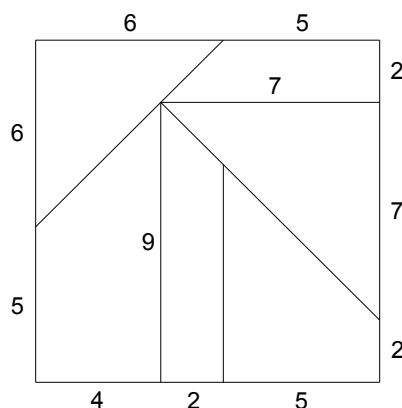

Figure 2.2. The puzzle presented to the students (reproduced from Brousseau, 1997, p. 177)

Students are divided into groups of six. Within each group, each student works independently on a separate piece of the puzzle. Brousseau's experiments with this type of situation show that almost all elementary students think that the appropriate thing to do is to add 3 cm to every dimension (Brousseau, 1997). This is consistent with the findings of the CSMS (Concepts in Secondary Mathematics and Science) study conducted in the United Kingdom (Hart, 1981).

After having added 3 cm to every dimension, the students then experience that the enlarged pieces are not compatible. The point of the situation for the students is to observe that for three sides in the puzzle,  $a$ ,  $b$ , and  $c$ , such that  $a + b = c$ , using the addition strategy, they have  $f(a) + f(b) \neq f(c)$  for images  $f$  of the sides. Brousseau (1997) reports that "this often leads students to observe the need to fulfill the characteristic condition of linearity" (p. 178); that the image of the sum of two lengths must be the sum of the images of these lengths.

The desired idea that might be prepared by displaying the lengths on the chalkboard (Table 2.1) is to find the image of 1 cm, where 1 cm is a unit of measure from which all lengths of the puzzle are composed. If it is known how to enlarge 1 cm, the other lengths can be enlarged as well.

**Table 2.1. Side lengths in original and enlarged puzzle**

Original piece	2	4	5	6	7	9
Enlarged piece			8			

The reasoning aimed at is the following: It is known that the image of 5 parts is 8 parts; thus in order to find the image of 1, it is necessary to divide 5 into five parts, and hence, 8 will need to be divided into five parts as well. It is intended that this representation of proportionality will prompt the students to argue something along the lines of the following: Because 5 times the image of 1 measures 8, the image of 1 is  $8/5$ , or 1.6. With the background of this experience, a principle for similarity of shapes (enlargement of a piece of the puzzle) can be formulated by the students: the side lengths should be multiplied by a fixed factor.<sup>13</sup> Brousseau's example here can be seen to be consistent with the conceptual dif-

---

<sup>13</sup> I illustrate here briefly a didactical situation that is elaborated in more detail in Brousseau (1997, pp. 177-179). Brousseau notes that it is relevant also to find the image of fractional and decimal lengths.

ficuity of proportional reasoning experienced by students that is widely reported in the literature (e.g., Hart, 1981; Hoyles, Noss, & Pozzi, 2001; Karplus, Pulos, & Stage, 1983; Vergnaud, 1983).

The above example was provided to illustrate the idea of an epistemological model. It consisted of, first, a model of the target knowledge (the principle that similarity is a multiplicative structure), which was modelled by similar dissections of squares. Second, it consisted of a proposed model of the process of coming to know the target knowledge, which was modelled by the “imagined trajectory” of students’ engagement with the task of enlargement of a puzzle into a similar puzzle.

Brousseau (2000)<sup>14</sup> makes a distinction between didactique and general didactics. He claims that development of knowledge in the field of didactique is conditioned by the particular content knowledge at stake (mathematics) whereas general didactics is considered insignificant for didactique. According to Brousseau, many researchers’ position (outside didactique) is that methodology and theories of teaching should first be general theories that are independent of content, to be applied subsequently to a particular content. In such a perspective, he continues, didactics of mathematics would first be a general theory of didactics, a position very different from the one proposed in didactique. “Didactique begins with the determination of its object: a particular piece of knowledge. There is no reason to believe that the invention or practice of geometry can be the same adventure as that of algebra” (Brousseau, 2000, pp. 22-23). He claims that for the student as for humanity, a new piece of knowledge is a lot more than a simple application of a more general knowledge, and maintains that “general didactics can only, in my view, be a chancy metadidactics” (Brousseau, 2000, p. 23). Consequently, the theory of didactical situations in mathematics starts with the study and modelling of didactical situations proper to a specific piece of mathematical knowledge.

---

<sup>14</sup> The article referred to is Brousseau’s plenary lecture at the *Fifth National Congress of Educational Research*, Aguascalientes, Mexico, October, 1999.

## 2.2 A scientific approach to the set of problems posed by the teaching and learning of mathematical knowledge

In my explication of the theory of didactical situations in mathematics, the main publication I will draw on is (Brousseau, 1997), which is a selection of Brousseau's papers written between 1970 and 1990.<sup>15</sup> The editors of the volume have not only translated the chosen papers, they have also edited, annotated, and organised them so as to provide a coherent and comprehensive presentation of the theory. To avoid confusion of pronouns in this chapter, female gender is used to refer to a generic teacher whereas masculine gender is used to refer to a generic student.<sup>16</sup>

Brousseau (1997) uses several metaphors in his theory (e.g., game, didactical contract, didactical engineering, devolution). It is relevant to make a comment on how to understand them. It may be helpful to notice that these metaphors are not to be taken as accurate portrayals of a reality (the mathematics classroom), but as active tools to interpret that reality. According to Herbst and Kilpatrick (1999), metaphors and models are productive because of their distance from the reality to which they refer; they provide plausible conjectures that it may not be possible to formulate from observation of reality alone (see Chevallard, 1992). In this dissertation I use metaphors from the theory of didactical situations in line with Brousseau.

### 2.2.1 A theory about a triadic didactical relationship

Brousseau (1997) writes about mathematicians' presentation of mathematical knowledge:

---

<sup>15</sup> The theory of didactical situations is developed on the basis of observations and experimentations in a mathematics classroom at École Jules Michelet in Talence, near Bordeaux (Brousseau, 1997). This school, built in 1971, was designed by Brousseau as an instrument to allow the observation of students and teachers in their *natural milieu*. But this "observation school" was an ordinary school in the sense that it was not an experimental school, nor was it a pilot or model school in which a supposedly better pedagogy was practiced. It was not a school for special children, gifted or in difficulties with mathematics or anything else. The curriculum taught was that normally stipulated by the national Ministry of Education. According to Brousseau, the only thing extraordinary was that mathematics teaching was the object of scientific inquiry.

<sup>16</sup> In quotations from Brousseau's texts, however, female gender is used to refer to both the teacher and the student.



Mathematicians don't communicate their results in the form in which they discover them; they re-organize them, they give them as general a form as possible. Mathematicians perform a "didactical practice" which consists of putting knowledge into a communicable, decontextualized, depersonalized, detemporalized form. (p. 227)

But such a presentation removes all trace of the history of this knowledge, that is, of the succession of difficulties and questions which provoked the emergence of fundamental concepts, their use in formulating new problems, and the rejection of points of view found to be false or less helpful (Brousseau, 1997). To make teaching easier, the teacher replaces the true development of mathematical knowledge by an imaginary development. This means that certain notions and properties are isolated and taken away from the network of activities (of mathematicians) which provide their origins, meaning, motivation, and use; they are transposed into a classroom context. Epistemologists refer to this transfer of order and place as *didactical transposition*, a term first coined in 1985 by Yves Chevallard<sup>17</sup> (Kieran, 1998). Brousseau (1997) describes the teacher's task in these words:

The teacher first undertakes the opposite action [of that of mathematicians when they communicate their results]; a recontextualization and a repersonalization of knowledge. She looks for situations which can give meaning to the knowledge to be taught. But when the student has responded to the proposed situation, if the personalization phase has gone well she [the student] will not know that she has "produced" a piece of knowledge that she will be able to use on other occasions. In order to transform her answers and knowings into a body of knowledge, she will, with the assistance of the teacher, have to redepersonalize and redecontextualize the knowledge which she has produced so that she can see that it has a universal character, and that it is re-usable cultural knowledge. (p. 227)

Two different, and rather contradictory, roles of the teacher can be identified on the basis of this quotation from Brousseau (1997). One is to bring knowledge alive; to delegate to the students a situation which allows them to produce a response. The other is to transform this response into a piece of knowledge which can be used beyond the situation in which the students have produced it. These two roles of the teacher, termed respectively, *devolution* and *institutionalisation*, characterise the theory of didactical situations. They will be explained further below.

---

<sup>17</sup> Chevallard, Y. (1985). *La transposition didactique: Du savoir savant au savoir enseigné*. Grenoble, France: La Pensée Sauvage.

The theory of didactical situations in mathematics is a scientific approach to the set of problems posed by the teaching and learning of mathematics, in which the specificity of the knowledge taught is engaged and plays a significant role (Brousseau, 2000). The theory is about a triadic didactic relationship; the interplay between the teacher, the student (or rather, a group of students), and some particular mathematical knowledge. An important concept in the theory is constituted by the subset of the students' environment with only those features that are relevant with respect to the target knowledge. This concept is referred to as the *milieu*<sup>18</sup> and will be explained further in Section 2.4.4.

### **2.2.2 Learning, teaching, and knowledge in the framework of didactical situations**

In the theory of didactical situations, learning is understood as sense-making of situations in a milieu, and developing ways of coping with them. Teaching of some knowledge consists in organising the didactical milieu in such a way that this knowledge becomes necessary for the student to “survive” in it. A didactical milieu with this quality is referred to as an *adidactical*, appropriate situation. The notion of an adidactical situation will be explained in Section 2.4.1. Brousseau uses the metaphor “game” in his writing to refer to a situation which involves, first, the teacher's devolution to the students of an adidactical, appropriate situation. Second, it involves the students' adaptation to the situation; that is, their interaction with the problems given to them. The idea of game will be explained further in Section 2.3.6.

The kind of game the student has to play with the milieu, to survive in it, determines the kind of knowledge that he will acquire (Brousseau, 1997). If the situations in a mathematics classroom are such that a certain type of social behaviour is sufficient for survival, without any use of mathematical knowledge, then it is likely that it is the social behaviour the students will learn, not the mathematical knowledge. If the teacher teaches the students an algorithm to solve certain problems, it is likely that the students will learn how to use the algorithm, not how to solve problems. Thus, in the theory of didactical situations, “knowledge is

---

<sup>18</sup> The notion of “milieu” can be understood in an ecological sense; e.g., the Arctic is the natural milieu of the polar bear. Thus the didactical milieu is the natural milieu of the students. In order to “survive” in a milieu one has to get to know the “rules of the game” and develop strategies of winning the “game”.

[understood as] the outcome of the interactions between the student and a specific milieu organized by the teacher in the framework of a didactic situation” (Balacheff, 1993, p. 133). As described in Section 2.1, the crucial methodological principle of the theory of didactical situations is that a piece of mathematical knowledge is represented by an epistemological model, termed a *situation*, that involves problems that can be solved in an optimal manner using this knowledge (Bosch et al., 2005).

In the next section I present didactical phenomena connected with control of the didactical transposition, before I turn to elements for modelling of the fundamental relationships between the student (or, a group of students), the teacher, and mathematical knowledge.

### **2.3 Didactical phenomena connected with control of the didactical transposition**

In this section I present seven types of didactical phenomena, effects or techniques, characterised by Brousseau (1997), which illustrate how reciprocal obligations of the teacher and the students in teaching-learning situations constrain classroom interactions. The explication of the theory in terms of these didactical phenomena (presented in Sections 2.3.1 – 2.3.7) could be interpreted to be giving an impression that Brousseau sees teachers and teaching as in some way deficient or lacking essential competencies, and that it is his task as a researcher to compensate for their deficiencies. However, this would be unfair to Brousseau, who reveals in his writing that he is concerned to analyse the *complexity* of teaching and learning mathematics.

Brousseau (1997) describes didactical techniques that he has observed in classrooms, techniques that I believe most mathematics teachers recognise as fairly widespread. This is not to say that mathematics teachers or teaching is necessarily deficient, rather it is a recognition that teaching and learning mathematics is challenging and complex, as noted by several researchers in mathematics education. Further, it is possible that students are complicit in the use of these techniques as they “appear” to make success easier to come by. In the following paragraphs I refer to some of the researchers who have written about the complexity of teaching and learning mathematics.

Hans Freudenthal (1991) asserts that mathematics is different from other disciplines in the way that there is a difference between the “content” (the substance of mathematics) and “form” (the way in which the substance is presented). Richard Skemp’s (1982) distinction between “surface structures” and “deep structures” in mathematics can be interpreted similarly to be about form and content. He observes that people try to communicate the deep structures (conceptual structures) with help of surface structures (by writing or speaking symbols). Further, he makes

the point that “even within our minds the surface structures are much more accessible [than the deep structures], as the term implies. And to other people they are the only ones which are accessible at all” (Skemp, 1982, p. 282).

Raymond Duval (2006) is a third researcher who can be interpreted to deal with a similar distinction as that recognised by Freudenthal (1991). He claims that the crucial problem of mathematics comprehension for learners arises from the cognitive conflict between two quite opposite requirements for engagement in mathematical thinking, related to the representation of mathematical objects:

In order to do any mathematical activity, semiotic representations must necessarily be used even if there is the choice of the kind of semiotic representation. But the mathematical objects must never be confused with the semiotic representations that are used. (Duval, 2006, p. 107)

The descriptions of mathematics and of teaching and learning mathematics given by Freudenthal (1991), Skemp (1982), and Duval (2006) indicate what is noticed in the *Cockcroft Report*; that “mathematics is a difficult subject both to teach and to learn” (Cockcroft, 1982, p. 67). Brousseau (1997) remarks that

students’ reasoning is formed by a collection of constraints of didactical origin which modify the meanings of their responses and those of the knowledge they are taught; . . . these constraints are not arbitrary conditions freely imposed by teachers; they exist because they play a certain rôle in the didactical relationship. (p. 264)

I interpret him here as referring to the reciprocal obligations of the teacher and the student in the didactical relationship as being the origin of the phenomena which constrain the meaning of the knowledge taught and learned. These constraints exist because mathematics is a difficult subject to teach and to learn, as noted above, and not because teachers are in some way deficient. Brousseau, further, remarks that “the disappearance of meaning [which is the effect of some of the didactical phenomena described by the theory of didactical situations], in the didactical relationship as well as in teaching, is a normal phenomenon: teachers, just as their students, are right in trying to obtain the expected answer for the minimum cost” (Brousseau, 1997, p. 266). He objects to the way a researcher (Baruk, 1985, as cited in Brousseau, 1997, p. 265) blamed teachers for “abnormal” responses given by “normal” students in an ex-

periment.<sup>19</sup> Brousseau asserts that it is not possible for teachers “to perceive all the phenomena that make a communication of knowledge ‘abnormal’ and to prevent them from happening or correct them if they occur” (Brousseau, 1997, p. 266). Didactique aims at explanation and comprehension of the problems related to teaching and learning of mathematics, and Brousseau (1997) claims that, “often, the explanation of a failure or a difficulty allows both the teacher and the student to alleviate their guilt and re-orient themselves towards more positive points of view” (p. 267). I will now turn to a presentation of the didactical phenomena described in the theory of didactical situations.

Brousseau (1997) introduces seven types of didactical phenomena. Although I have identified only three of these in my analyses, I will nevertheless describe all seven here. The seven are: “the Topaze effect”, “the Jourdain effect”, “the improper use of analogy”, “the metacognitive shift”, “the metamathematical shift”, “the Diénès effect”, and “the aging of teaching situations”.<sup>20</sup> They will be presented in the following sections.

### **2.3.1 The Topaze effect**

The Topaze effect is the phenomenon of giving away the answer in the question. Its name is taken from the play *Topaze*, written by Marcel Pagnol in 1928 (Brousseau, 1997). Topaze is the teacher who is giving a dictation to a weak student. The answer that the student must give is determined in advance; the teacher chooses questions to which the answer can be given. The knowledge necessary to produce these answers changes, so does its meaning. Faced with the student’s continued difficulties in giving the answer, the teacher poses easier and easier questions. If the target knowledge disappears completely, the phenomenon is referred to as the Topaze effect.

To illustrate the Topaze effect I provide the following example:<sup>21</sup> A student is given a word problem:

---

<sup>19</sup> Brousseau refers here to the experiment of the research team of Grenoble IREM (Institut de Recherche sur l’Enseignement des Mathématiques), called “the age of the captain”. This experiment will be described in Section 2.4.2.

<sup>20</sup> Didactical phenomena identified through analyses of my empirical material are the Topaze effect, the Jourdain effect, and the metamathematical shift.

<sup>21</sup> Examples presented in this chapter which are not referenced to sources, are invented by me to illustrate didactical phenomena. These examples are inspired from my own practice as a teacher educator in mathematics.

In a school there are 170 Grade 4 students who are to be equally divided into 5 classes. How many students will there be in each class?

The aim of the task is the student's development of understanding of partitive division as a model of an everyday situation. Because the student struggles to find out how to translate the given word problem into an arithmetic task, the teacher tries to help him visualise the problem by a diagram with five blocks which intends to illustrate that the number of students in each class is found by dividing the total number of students by the number of classes (each class is represented by a block). However, the student does not benefit from the teacher's illustration and explanation, whereupon the teacher just tells the student that he should divide the total number of students by the number of classes. The student then finds the answer to the division problem by using the division algorithm.

This incident illustrates the Topaze effect because the target knowledge has disappeared; the student demonstrates proficiency in using the division algorithm, but this was not the knowledge aimed at.

### **2.3.2 The Jourdain effect**

The Jourdain effect is a form of Topaze effect, and denotes the phenomenon of giving a scientific name to a trivial activity. The name of this phenomenon indicates a reference to the scene in Molière's play *Le Bourgeois Gentilhomme*, in which the philosophy teacher reveals to Jourdain that he has been speaking prose all his life without being aware of it (Molière, 1670/1732, Act 2, Scene 4).<sup>22</sup> The humour of the scene is based on the absurdity of giving scientific validity to ordinary activities (here, speaking prose).

An example of the Jourdain effect can be illustrated by a teaching situation which involves algebraic expression of the general member of a sequence mapped from a linear shape pattern. The students have found a correct formula by construction of a table with values and the subsequent application of a strategy of guess-and-check. The teacher sees in the stu-

---

<sup>22</sup> *Le Bourgeois Gentilhomme* (The Bourgeois Gentleman) is a *comédie-ballet*, first presented at Chambord in October 1670, before the court of Louis XIV. In the play, Jourdain, a non-educated man with no relations to aristocracy, aspires to becoming part of nobility, if not by blood then at least by manners and education. So he hires a music master, a dancing master, a fencing master, and a philosophy master. The play satirises attempts at social climbing and the bourgeois personality, making fun both of the vulgar, pretentious middle-class and the self-important, snobbish aristocracy. Retrieved from <http://encyclopedia.thefreedictionary.com/Le+Bourgeois+gentilhomme>.

dents' formula the linearity of the pattern, and comments that the students have discovered the linearity. If the students have no notion of the generality of the formula they have developed, the situation is analogous with Molière's Jourdain who had no notion of prose. This circumstance is a didactical phenomenon which is characterised by the teacher's recognition of an item of scientific knowledge in a student's answer, even though his answer is in fact motivated by ordinary causes.

### **2.3.3 The improper use of analogy**

The phenomenon of improper use of analogy is characterised by the teacher giving to the students a problem so as to highlight its analogy with a problem previously solved in the class. The students find the solution by reading the didactical indications and not by involving themselves in the given problem (Brousseau, 1997). Implicit suggestion of analogy is a typical way of reproducing Topaze effects. Brousseau (1997) comments, however, that it is a natural practice: "If a few students have not learned, they must be given a second attempt with the same subject matter" (p. 27).

The following example illustrates the phenomenon of improper use of analogy: A teacher has given a word problem which is problematic to a student. The teacher presents its solution on the chalkboard, whereupon the student reacts by telling that he does not understand what the teacher has done. Then the teacher gives to him a new problem which is identical to the original problem apart from the quantities which are replaced by new ones. Hence, the student just has to recall what the teacher did to resolve the first problem, and solve the new problem by the same method. This is an incident of improper use of analogy because the student is enabled to find a solution without involving himself in the given problem.

### **2.3.4 The metacognitive shift**

The metacognitive shift is an effect of the teacher's obligation of teaching at all costs. When a teaching activity has failed, the teacher can feel forced to justify herself and, in order to continue her activity, takes her own formulations and methods as objects of study instead of genuine mathematical knowledge. This may materialise in the form of teaching students the rules of interpreting and using tools (e.g., counters, blocks, graphical representations) that were supposed only to help students un-

derstand the meaning of a mathematical concept. Brousseau illustrates the metacognitive shift by examples from the New Math reform period in the 1960s; the use of Venn diagrams in teaching the algebra of sets<sup>23</sup> and arrow diagrams in teaching about relations and functions, a method attributed to the Belgian mathematician, Georges Papy (Brousseau, 1997, p. 26).

During the New Math reform period, elementary school children were taught operations on sets. Because they could not be expected to reason about these operations using the language of formal logic, a less formal language was introduced. This language was based on a “model” originating from Euler (1768, as cited in Brousseau, 1997, p. 73), which makes reference to various graphical representations: Euler diagram; Venn diagram; and, Papy figure (Brousseau, 1997, pp. 26-27). But this model did not allow the expected semantic control and caused teaching difficulties. Because of these difficulties, this “method” of teaching in its turn became the object of teaching and the students were given exercises just for the practice of the conventions of the representation. “With this process, the more the teaching activity produced comments and conventions, the less the student could control the situations which were being put to them” (Brousseau, 1997, p. 27). The metacognitive shift refers to the phenomenon that the teaching of for example Venn diagrams became an end in itself, whereas the intended knowledge (sets as mathematical structures) disappeared.

An example of the metacognitive shift in the context of generalisation of shape patterns<sup>24</sup> is the following: The teacher has presented a shape pattern that models a quadratic relationship and has given the students the task of finding an explicit formula for the general member of the sequence of numbers mapped from the shape pattern. The aim of the task is to identify an invariant structure in order to establish a functional relationship between  $n$  (the position of an element) and the numerical value of the  $n$ -th element of the shape pattern. The students have produced a sequence of numbers mapped from the first few elements and

---

<sup>23</sup> The algebra of sets refers to the set-theoretic operations of union, intersection and complementation, and the relations of equality and inclusion (see e.g., Stečkin, 1963/1999).

<sup>24</sup> A shape pattern is a sequence of *geometric configurations* which develop in conformity with a fixed procedure. The geometric configurations are referred to as *elements* of the shape pattern. A more detailed explanation of the concept shape pattern will be presented in Chapter 5.



have unsuccessfully used a strategy of “guess-and-check” to find a formula.

In an attempt to help them, the teacher encourages them to look at the differences between the members of their sequence (hereafter referred to as the original sequence). The students find the sequence of (first) differences and realise that these numbers are derived by adding the same constant to the preceding number. With some help from the teacher they find an algebraic expression for the  $(n - 1)$ -th difference and figure out that the  $n$ -th member of the original sequence is equal to the sum of the first member of the original sequence and all differences up to the  $(n - 1)$ -th difference (here I represent this sum by  $a_n = a_1 + \Delta a_1 + \Delta a_2 + \dots + \Delta a_{n-1}$ , where  $a_i$  is the  $i$ -th member of the original sequence, and  $\Delta a_i = a_{i+1} - a_i$ ). Now the teacher reminds them that the sum they have achieved is equal to the  $n$ -th partial sum of an arithmetic series, a formula with which they are familiar. The students recall this formula and use it to find an algebraic expression for the sum. They do not go back and reflect on the original shape pattern.

There has been a shift away from the defined goal of the task (to establish a functional relationship through identification of an invariant structure), towards a focus on a method of finding a formula. This incident can therefore be interpreted as a metacognitive shift.

### 2.3.5 The metamathematical shift

The phenomenon of the metamathematical<sup>25</sup> shift consists of substituting for a mathematical problem, a discussion of the logic of its solution and attributing the sources of error (in its solution) to a misunderstanding of that logic (Brousseau, 1997). An example of this phenomenon would be if a student originally is given a mathematical problem that requires solving an equation, and he fails in solving the equation. If the teacher, with the aim of improving the students’ proficiency in and understanding of solving equations, teaches the students a theory of equations, then there has been a metamathematical shift. That is, if the teacher, instead of communicating with the student about the original mathematical problem (the equation) states that an equation is a mathematical statement that asserts equality between two expressions. Further, she asserts that

---

<sup>25</sup> Metamathematics refers to the logical analysis of the fundamental concepts of mathematics, as number, equation, function, and so forth. That is, metamathematics is “the rigorous mathematical study of mathematics itself” (Gowers, 2008, p. 622).

this is the same as saying that the expressions are related by equality, which is an equivalence relation on a set (e.g., the real numbers). She explains that this means that for real numbers  $a$ ,  $b$ , and  $c$ , the following properties hold: reflexivity (for any  $a$ ,  $a = a$ ); symmetry (if  $a = b$  then  $b = a$ ); transitivity (if  $a = b$  and  $b = c$  then  $a = c$ ); addition property (if  $a = b$ , then  $a + c = b + c$ ); subtraction property (if  $a = b$ , then  $a - c = b - c$ ); multiplication property (if  $a = b$  then  $ac = bc$ ); division property (if  $a = b$  and  $c \neq 0$ , then  $\frac{a}{c} = \frac{b}{c}$ ); and, distributive property of multiplication over addition ( $a[b + c] = ab + ac$ ).

The above is an example of a metamathematical shift because logic and theory of relations belong to metamathematics, which involves an abstraction from the particular mathematical statement (the given equation) and concentrates only on its general form.

### 2.3.6 The Diénès effect

The belief in the existence of some kind of infallible genesis of mathematical knowledge that would be independent of the teacher's investment in the learning process is the basis of what Brousseau (1997) refers to as the *Diénès effect*. The Diénès effect is thus the phenomenon that the teacher is assured of success by means of effects which are independent of her personal investment.

Zoltan Paul Diénès, a Hungarian mathematician, became during the period of the New Math reforms known for his theory of the *psychodynamical process*, a “teaching model founded on the recognition of similarities among ‘structured games’ and on the schematization and the formalization of these guided ‘generalizations’” (Brousseau, 1997, p. 36). According to Willy Servais and Tamas Varga (1971), Diénès became well-known to elementary school teachers around the world for his blocks designed for the teaching of place value systems with various bases (“Diénès’ multibase blocks”), as well as blocks for the teaching of logic (“Diénès’ logic blocks”). An example with base three blocks for the learning of arithmetic (multiplication by the base number) is provided in the following paragraph.

The material consists of several blocks in base three; “cubes” of  $3^3 \text{ cm}^3$ , “plates” of  $3^2 \text{ cm}^3$ , “bars” of  $3 \text{ cm}^3$ , and “units” of  $1 \text{ cm}^3$ . The students are presented with an arrangement of base three blocks as shown in Figure 2.3 (on the next page). That is, they are presented with 2 plates, 1 bar, and 2 units. Representation in symbols of this arrangement is introduced as 212. The task is how the blocks would be arranged and represented if there had been three times as many objects as the original one.

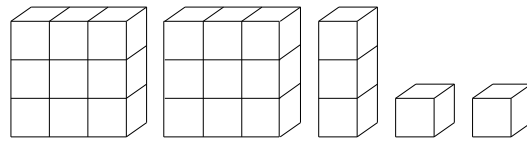

Figure 2.3. Arrangement of blocks to represent the number 212 in base three

The teacher reveals the “rule” by illustrating that with three times as many objects the following applies: For every unit, there will be a bar; for every bar there will be a plate; and, for every plate, there will be a cube. The blocks will be arranged as shown in Figure 2.4.

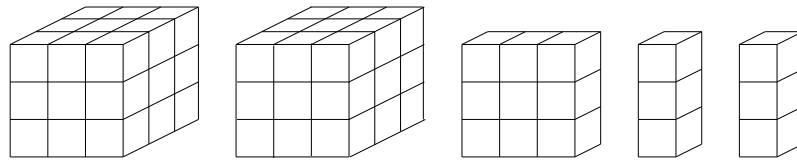

Figure 2.4. Arrangement of blocks to represent the number 2120 in base three

That is, there will be 2 cubes, 1 plate, 2 bars, and 0 units; its representation in symbols is 2120. So, the original arrangement, 212, has become 2120 and it is seen that the digits have “moved up” one level, each block being replaced by the block the next size up.

The next step is to let the students experience (by using other base blocks) that the shifting of the digits and getting zero units does not depend on the base used, as long as they multiply by the base number itself. If the students learn to manipulate the blocks but do not see through this activity to the mathematical knowledge that the blocks represent, it is an incident of what Brousseau refers to as the Diénès effect.

In Diénès’ psychodynamical process, knowledge is not organised as a response to a problem-situation which is the case in Brousseau’s theory. In Diénès’ theory knowledge is provided totally prepared by the culture which guarantees its validity and usefulness and leaves the student no responsibility but to adhere to it (Brousseau, 1997, p. 141). The psychodynamical process generally proceeds in six stages (accompanied by phenomena like, for example, that of generalisation): the playing stage; structured game; isomorphic games and abstraction; schematisation and formulation; symbolisation and formalisation; and, axiomatisation (for an outline of the psychodynamic process, see Brousseau, 1997, pp. 139-143).

Diénès’ theory was a motivation for the development of Brousseau’s theory of didactical situation in mathematics (Brousseau, 1997, 2000).

For this reason I include a relatively detailed outline of the didactical phenomenon referred to as the Diénès effect. Central in both Diénès' theory and Brousseau's theory is the notion of game. There are two aspects that distinguish the two theories. First, for Diénès, a game is defined as a rule-bound play (Diénès, 1963), and it is not assumed that there are some strategies for winning the game, as in Brousseau's theory. In the theory of didactical situations, on the other hand, knowledge is the outcome of the game (the construction of a strategy of winning the game), but the game does not resemble the knowledge, and the players are not playing with the target knowledge. However, playing with the target mathematical knowledge is exactly what the games are all about in Diénès' theory: "The structure of the game and what knowledge 'is' are identical!" (Brousseau, 1997, p. 37). Brousseau (1997) claims that in order to play the game in Diénès' theory, the student must understand the rule of the game, which means that he must possess the knowledge that the teacher is claiming to teach him. To avoid teaching the student the rule (because this would transform the game into an exercise), "the teacher tries to make the student guess the rule – an activity which is not theorized in the psychomathematical process" (Brousseau, 1997, p. 37).

Second, Brousseau (1997) does not, as he claims that Diénès does, believe in any infallible genesis of mathematical knowledge that is independent of the teacher's engagement. This can be exemplified by their divergent views of the process of abstraction. Diénès considers abstraction to result inevitably from the student's engagement in the stages of structured game and isomorphic games. In Diénès' theory, abstraction usually is not composed of any specific problem-situation (no new decision on the part of the teacher); "it appears as an answer, entirely the student's responsibility, given in the earlier stages which are at the same time the necessary and sufficient condition for it" (Brousseau, 1997, p. 140). Brousseau, on the other hand, claims that what assures the process of abstraction is not an arbitrary law of the genesis of knowledge, but the existence of the *didactical contract*, which is about the reciprocal obligations of the teacher and the student in the teaching-learning situation related to some target mathematical knowledge. According to Brousseau, the possibility of the existence of the Diénès effect shows the necessity of integrating the teacher-student relationship in any didactical theory.

An example which illustrates the Diénès effect, in addition to the one presented above with multibase blocks, is the use of a device developed by Diénès for making children construct the concepts of algebra. Servais and Varga (1971) write that the balance as a traditional device for illustrating solution of equations is replaced by Diénès by a simple beam with hooks at equal intervals from the fulcrum. Identical rings may be hung on different hooks. Diénès (1964, as cited in Servais & Varga,

1971) claims that students, as a consequence of engaging with the beam, discover the law of moments experimentally, and that it therefore becomes possible to prove that multiplication is distributive over addition. The belief of the teacher (or the researcher) that the students' manipulations with the rings on the beam will make them draw inferences about the properties of multiplication as an arithmetic operation, is an incident of what Brousseau (1997) refers to as the Diénès effect.

### 2.3.7 The aging of teaching situations

The teacher's opinion that it is difficult to reproduce the same lesson (even with new students) may lead to modifications in the formulation of her explanations and instructions, or of the examples and exercises she uses. It may even lead to modifications in the structure of the lesson. Brousseau (1997) refers to this phenomenon of the teacher's need to change a lesson as the aging of teaching situations. He claims that the phenomenon of aging raises an important question for didactic concerning the *meaning* attributed to items of knowledge appropriated by the student: "What really is reproduced during the course of a lesson?" (Brousseau, 1997, p. 28).

The phenomenon of aging of teaching situations can be exemplified by a situation where the target knowledge is a functional relationship between the position of elements in a shape pattern and the numbers represented by the elements (the sequence of numbers arising from the shape pattern). The teacher presents the same examples as those she has presented to previous classes: She demonstrates how the first few elements of different shape patterns can be partitioned to illustrate the invariant structure of the patterns. In each case she chooses a generic example (one of the elements of the pattern) to show the functional relationship between position and numerical value. In previous classes she has introduced the concept of a "generic example". This time however, she uses a generic example implicitly; that is, without making a point of its role in justification of the conjectured algebraic formula for the generality of the pattern. After the teacher's presentation of the examples, the students are able to use the method of partitioning to find algebraic expressions for the general member of sequences mapped from shape patterns. However, the new students lack the metacognitive support of the concept of generic example, with the consequences it has for reasoning about the validity of algebraic formulae.

The provided example illustrates the phenomenon of aging of teaching situations because the teacher has modified her formulations and explanations. At the surface, the outcome of the reproduced lesson is apparently the same as for the old lesson (because the students can represent generality in shape patterns by algebraic symbols). However, the *meaning* of the knowledge appropriated during the reproduced lesson is

different; the new students do not have at their disposal the concept of a generic example.

#### *The didactical phenomena placed in three categories*

The seven didactical phenomena presented above illustrate different ways in which the reciprocal obligations of the teacher and the students constrain the teaching and learning of mathematics. They can be placed in three categories: The first category represents different ways in which the teacher offers tasks to students that enable students to evidence possession or appropriation of some knowledge, but where this knowledge is different from the knowledge originally aimed at by the teacher. The Topaze effect, the Jourdain effect, and the improper use of analogy belong to this category. The second category represents different ways in which the teacher tries to help the students learn better, but the chosen method does not bring about the desired results. The metacognitive shift, the metamathematical shift, and the Diénès effect belong to this category. The third category represents an inherent factor of teaching which signifies that what proceeds in the classroom cannot be scripted. The aging of teaching situations belongs to this category.

The didactical phenomena presented in this section are important in an analysis of what is being produced in a teaching situation in the way they describe how the target mathematical knowledge is related to the didactical transposition. The phenomena have laid a foundation for the *description* of a theory that accounts for its known or inferred properties and can be used for further study of the characteristics of the theory. That is, it is a model of teaching-learning situations in mathematics, which will be outlined in the next section.

## **2.4 Modelling of teaching situations**

In this section the fundamental relationships between the student (or group of students), the teacher, and mathematical knowledge are identified. These relationships enable the modelling of teaching-learning situations in mathematics.

### **2.4.1 Devolution, adidactical situations, and didactical situations**

According to Brousseau (1997), the modern conception of teaching requires that the teacher elicits the students' intended learning by a careful choice of "problems" that she gives to them.

These problems, chosen in such a way that students can accept them, must make the students act, speak, think, and evolve by their own motivation. Between the moment the student accepts the problem as if it were her own and the moment she produces her answer, the teacher refrains from interfering and suggesting the knowledge that she wants to see appear. The student knows very well that the problem was chosen to help her acquire a new piece of knowledge, but she must also know that this knowledge is entirely justified by the internal logic of the

situation and that she can construct it without appealing to didactical reasoning. . . . Such a situation is called an adidactical situation. (Brousseau, 1997, p. 30)

An *adidactical situation* is thus a situation in which the student takes a problem as his own and solves it on the basis of its internal logic without the teacher's guidance and without trying to interpret the teacher's intention with the problem. In the theory of didactical situations, an epistemological hypothesis is that to any piece of mathematical knowledge, it is possible to arrange an adidactical situation which sustains meaning. Such a situation is referred to as a *fundamental situation*: "Each item of knowledge can be characterized by a (or some) adidactical situation(s) which preserve(s) meaning; we shall call this a fundamental situation (Brousseau, 1997, p. 30). An example of an adidactical situation which can be characterised as a fundamental situation, is the puzzle situation described in Section 2.1. It is a fundamental situation for the principle that similarity is a multiplicative structure.

The *devolution*<sup>26</sup> of an adidactical learning situation is the act by which the teacher makes the student accept the responsibility for an adidactical learning situation or for a problem, and the teacher accepts the consequences of the transfer of this responsibility (Brousseau, 1997, p. 230). The student cannot engage in any adidactical situation immediately; the teacher arranges an adidactical situation which the student can handle. The design of an adidactical situation depends upon the student's prior knowledge. Adidactical situations are arranged with didactical purpose and determine the knowledge taught. Having introduced the notion of devolution of an adidactical situation, it is now possible to explain what a didactical situation is:

[The] situation or problem chosen by the teacher is an essential part of the broader situation in which the teacher seeks to devolve to the student an adidactical situation which provides her with the most independent and most fruitful interaction possible. For this purpose, according to the case, the teacher either communicates or refrains from communicating information, questions, teaching methods, heuristics, etc. She is thus involved in a game with the system of interaction of the student with the problem she gives her. This game, or broader situation, is the didactical situation. (Brousseau, 1997, pp. 30-31)

---

<sup>26</sup> Brousseau (1997) explains: "Devolution was an act by which the king, by divine right, gave up power in order to confer it to the Chamber. 'Devolution' signifies 'It is no longer I who wills [*sic*], it is you who must will, but I am giving you this right, because you cannot take it yourself'" (p. 249).

This means that an adidactical situation is part of the didactical situation, which is the broader situation (game) with the system of interaction of the students with the milieu arranged with the purpose of the students' appropriation of the target knowledge without the teacher's intervention. Situations of action, formulation, and validation are intentionally adidactical situations, whereas the situation of institutionalisation is not adidactical. The different didactical situations will be explained in Section 2.4.3.

The notion of teaching and learning can now be reformulated in Brousseau's terms: "Teaching is the devolution to the student of an adidactical, appropriate situation; learning is the student's adaptation to this situation" (Brousseau, 1997, p. 31). What makes an adidactical situation *appropriate* is that the student can handle it. That depends upon two conditions: first, that the student has prior knowledge that enables him to engage with the situation; second, that the *milieu* created by the teacher provides the student with knowings that enable him to develop the knowledge aimed at.

#### **2.4.2 The didactical contract**

As stated above, the didactical situation can be described through the metaphor of game. The rules and strategies of the game between the teacher and the student-milieu system, which are specific for the knowledge in play, are called the *didactical contract*. Brousseau explains:

In a teaching situation, prepared and delivered by a teacher, the student generally has the task of solving the (mathematical) problem she is given, but access to this task is made through interpretation of the questions asked, the information provided and the constraints that have been imposed, which are all constants in the teacher's method of instruction. These (specific) habits of the teacher are expected by the students and the behaviour of the student is expected by the teacher; this is the didactical contract. (Brousseau, 1980, as cited in Brousseau, 1997, p. 225)

The questions asked, the information provided and the constraints that the teacher has imposed are determined by the knowledge that the teacher intends the student to learn. This implies that there are rules in the didactical situation which are specific for the target mathematical knowledge. These rules are crucial for the definition of the didactical contract. In a didactical situation there are also rules which are relevant from the point of view of the general culture of the classroom (classroom management, social behaviour, etc.). If these rules have nothing (or little) to do with the target knowledge, they are not part of the *didactical contract*. "The didactical contract is not a general pedagogical contract" (Brousseau, 1997, p. 31).



As an example of the didactical contract used as an analytical tool, I provide Brousseau's analysis of students' responses to a problem referred to as the "age of the captain" problem<sup>27</sup> (Brousseau, 1997, pp. 263-265): "On a boat, there are 26 sheep and 10 goats. What is the age of the captain?" In third grade, 78 % of the students gave the answer 36. Brousseau (1997) shows how the notion of didactical contract allows one to restore rationality in the students' behaviour: The students' responses are a plausible consequence of a break in the didactical contract associated with elementary word problems. The contract in this case involves that students are supposed to use the numbers in the text to accomplish a hidden arithmetic operation. Because word problems must be solved utilising the mathematics learned, contexts are chosen to contain indicators which enable students to ignore context and identify relevant mathematical information. The task of the student, according to the contract, is not one of making sense of the situation by using mathematics, but one of suppressing the situation so as to find the mathematics. The students' strange answers are observed because the problem and the conditions under which it is posed violate the conditions that students reasonably can expect from a school mathematical problem (teachers are not supposed to ask questions which cannot be answered by utilising prior knowledge and the information given). The results of the "age of the captain" problem become meaningful when interpreted in terms of the students' obligations to produce an answer according to the didactical contract of elementary word problems. An interpretation of the responses within cognitive explanations of students' personal knowledge is hard to imagine.

Brousseau (1997) observes that "students' reasoning is formed by a collection of constraints of didactical origin which modify the meanings of their responses and those of the knowledge they are taught" (p. 264). Negotiation of a didactical contract is a tool for the devolution of an adidactical learning situation to the student. When the devolution is such that the student no longer takes into account any feature related to the didactical contract but just acts with reference to the characteristics of the adidactical situation (that is, the student uses his prior knowledge and

---

<sup>27</sup> The problem was posed to third-grade and fifth-grade students as an experiment by a research team of the Grenoble IREM (Institut de Recherche sur l'Enseignement des Mathématiques).

tries to solve the problem on the basis of its internal logic), an ideal state is accomplished.

The “traditional” didactical contract (i.e., a contract not informed by didactique) does not include an adidactical situation. I understand Brousseau (1997) to mean that if the teacher “tells” the student the target knowledge, or uses some form of “didactical situation”, then the student has difficulty in appropriating the target knowledge because it cannot be separated from elements within the didactical situation, which point to the resolution of the problem. In this sense, if the student expects the teacher to disclose new knowledge, and the teacher does not do this, the contract is broken. In circumstances with a “traditional” didactical contract, “it is in fact *the breaking of the contract* that is important” (Brousseau, 1997, p. 32).

According to Brousseau (1997), a totally explicit contract will not bring about the desired learning. “In particular, clauses concerning the breaking and the stake of the contract cannot be written in advance. Knowledge will be exactly the thing that will solve the crises caused by such breakdowns; it cannot be defined in advance” (Brousseau, 1997, p. 32). The didactical contract is a contract in the sense that it regulates what can be done (from the point of view of legality) even if the clauses of the contract are not explicit. The contract becomes visible when it is broken, as in the “age of the captain” problem. At the moment of a breakdown of the didactical contract, the important enterprise is the “search for a new contract which depends on the new ‘state’ of knowledge, acquired and desired” (Brousseau, 1997, p. 32). This makes Brousseau claim that

the theoretical concept in didactique is therefore not the contract (the good, the bad, the true, or the false contract), but the hypothetical process of finding a contract. It is this process which represents the observations and must model and explain them. (Brousseau, 1997, p. 32)

The observations referred to by Brousseau (1997) are those done by the teacher in the metadidactical situation, where she reflects on the didactical situation, relative to some particular knowledge, and tries to find a didactical contract which models the observations. This means that the teacher reflects on what kinds of interactions with the milieu are necessary to foster the desired learning. The role of the teacher in the metadidactical situation where the negotiation of the didactical contract takes place, will be explained further in Section 2.4.4, where I explain the concept of milieu. In the same section an example is provided that illustrates the different roles of the teacher and student in the didactical situation.

### **2.4.3 Different types of didactical situations**

There are different types of didactical situations, in which the role of the teacher and the status of knowledge change. Brousseau (1997) categoris-

es didactical situations in mathematics into four types which (ideally) occur chronologically; situations of action, formulation, validation, and institutionalisation. Each situation depends on the accomplishment of the antecedent situation. The four types of didactical situations represent in the theory of didactical situations the “genetic” way of reinventing mathematical knowledge. Adidactical situations usually take place within situations of action, formulation, and validation whereas the situation of institutionalisation is a didactical situation. In the following I describe these situations and explain the different roles of the teacher, and the status of knowledge in each of them.

### *The situation of action*

The teacher organises a milieu for the students to engage with and then completely withdraws from the scene. This is supposed to be an adidactical situation in which the students engage with the presented mathematical problem on the basis of its internal logic without the teacher’s intervention. The milieu for the students is that of a mathematical problem so designed that two conditions are fulfilled: First, the students are willing to adopt the problem as their own, and want to solve it to satisfy their own curiosity or ambition. Second, the students have the means (prior knowledge and experiences) to construct the solution by themselves. To construct a solution, following Brousseau’s (1997) metaphor, means to develop strategies to win the game. Generally, a strategy is adopted by intuitive or rational rejection of an earlier strategy (Brousseau, 1997, p. 9). A “final” strategy is therefore a result of repeated experimentation and refined strategies related to the problem-setting. The students organise their strategies and construct a representation of the situation which serves as a “model” that guides them in their decisions. This model is an example of relationships between certain objects or rules that they have perceived as relevant in the situation. “The set of relationships can remain more or less implicit; the [student] plays according to the model before being able to formulate it” (Brousseau, 1997, p. 9).

Brousseau (1997) writes that the status of an implicit model in the classroom is that of a *protomathematical notion* (p. 162). Protomathematical notions are original or primitive notions that are precursors to mathematical notions as we know them today (see e.g., Chevallard, 1990). An example of a protomathematical notion is the notion of a “general number”, which, according to Radford (1996), is the basis for development of a formula in the context of generalisation of shape patterns or numerical patterns. A general number is categorised by Dietmar Küchemann (1981) as a preconcept to the concept of variable, and may as such be viewed as a protomathematical notion.

### *The situation of formulation*

The milieu for the students in the situation of formulation is developed on the basis of the shared experience in the situation of action: The students exchange and compare observations between themselves. A main purpose in the situation of formulation is to develop language to formulate their observations and agree on some common meanings. In the situation of formulation, the teacher re-enters the scene to chair the exchanges and make sure that all formulations are made “visible” in the classroom.

Knowledge in this situation appears as a personal experience, which needs to be communicated in order for others to share the experience and make up their minds about the strategy developed. In this way “situations of formulation allow the acquisition of explicit models and languages which, in cases where mathematical notions are not yet in existence, are given the status of *paramathematical notions*” (Brousseau, 1997, p. 162). Motivated by Apostolos Doxiadis (2003), I understand paramathematical notions to be notions used in mathematical activity; for example, the notions of equation and variable. These are notions which are part of the teacher’s instructions in mathematics, but they are not in the same way part of a mathematician’s consciousness: Paramathematical notions are used by mathematicians implicitly when they for instance solve equations and when they deal with variables during work with mappings.

### *The situation of validation*

The situation of validation is about establishment of theorems. For a model or a theory to be qualified as a valid strategy of winning the game there is a need for argumentation. Brousseau (1997) claims that

to state a theorem is not to communicate information, it is always to confirm that what one says is true in a certain system; it is to declare oneself ready to support an opinion, to be ready to prove it. It is therefore not a question only of the student’s “knowing” mathematics, but of using it as a reason for accepting or rejecting a proposition (a theorem), a strategy, a model, that which requires an attitude of proof. (p. 15)

He, further, asserts that this attitude of proof is *not innate* and therefore needs to be developed and sustained through specific didactical situations; situations of validation. Brousseau explains how the aim of conviction and the notion of truth imply that construction of mathematical knowledge (establishment of propositions) is primarily a *social activity*:

In mathematics, the “why” cannot be learned only by reference to the authority of the adult. Truth cannot be conformity to the rule, to social convention like the “beautiful” and the “good”. It requires an adherence, a personal conviction, an internalization which by definition cannot be received from others without losing its very value. We think that knowledge starts being constructed in a genesis of which Piaget has pointed out the essential features, but which also involves

specific relationships with the milieu, particularly after the start of schooling. We therefore consider that for the child, making mathematics is primarily a social activity, not just an individual one. (Brousseau, 1997, p. 15)

Piaget believed that learning resulted from a child's action related to its external world. His stance is described by Jerome Bruner (1985) as "the paradigm of a lone organism pitted against nature" (p. 25). Piaget has a rather discouraging view on teaching, illustrated in his own words: "Each time one prematurely teaches a child something that he could have discovered himself, the child is kept from inventing it and consequently from understanding it completely" (Piaget, 1970, p. 715). Brousseau's (1997) two quotations above show that he holds that the necessary attitude of proof cannot be taught to the child. But Brousseau, as opposed to Piaget, does not think that the individual student can acquire or discover this attitude. Brousseau emphasises the importance of the student's engagement in the game with the didactic milieu, where the activity of bringing convincing reasons to the fore will generate the mathematical knowledge.

In the situation of validation the students try to explain some phenomenon or verify a conjecture. According to Brousseau (1997), the teacher acts as a chair in a scientific debate and intervenes only to structure the debate, draw the students' attention to possible inconsistencies, and encourage them to use more precise mathematical concepts. Knowledge, in this situation, appears as *mathematical notions* (Brousseau, 1997, p. 162). The knowledge appropriated by the students in the situation of validation has the features of a theory in the making, not of an institutionalised theory.

#### *The situation of institutionalisation*

Brousseau (1997) claims that for a student's model or theoretical conjecture to be institutionalised, "it must already have functioned as such in scientific debates and in students' discussions as a mean [*sic*] of establishing or rejecting proofs" (pp. 161-162). This points at the importance of the preceding situations (situations of action, formulation, and validation), where the theory has functioned as a solution to a problem given to the student under conditions which allow him to construct the solution by himself or to make a choice (based on his own judgement, without any didactical intentions) among several alternative solutions.

The teacher, in the situation of institutionalisation, plays the role of a representative of the official curriculum, of the textbook, and of the mathematical community. She informs the student about conventional terminology and highlights definitions and theorems considered important for the contextualised knowledge to gain the status of cultural knowledge so that it can be used in settings other than in the original one set up by the teacher (i.e., for the knowledge to be decontextualised).

Knowledge, in this situation, acquires the features of a law rather than of an answer to a mathematical problem. It is justified through the authority of the institution (Brousseau, 1997, p. 44).

Brousseau (1997) states that for teachers there is a great temptation to cut out the double work of recontextualisation and redecontextualisation and make the students learn a text of knowledge directly. If this is done, situations of institutionalisation will dominate the classroom. In this case, the other types of didactical situations may appear in degenerate form, caused by one or several of the phenomena connected with control of the didactical transposition (as described in Section 2.3), under the pressure of the didactical contract.

#### *Adidactical situations and their feedback*

As explained in Section 2.4.1, an adidactical situation is a situation in which the student takes a problem as his own and solves it on the basis of its internal logic without the teacher's intervention. Adidactical situations are valuable, not only because of the ideological advantage of devolving to the student a responsibility for solving a problem that is meaningful to him, but also because of the epistemological importance of the *adidactical milieu*, which for the student is without didactical intentions (Herbst & Kilpatrick, 1999). Within and against this milieu, the student's activity may generate knowings that may eventually lead to a valid institutionalisation of the target knowledge. The adidactical milieu is "the image, within the didactical relationship, of the milieu which is external to the teaching itself; that is to say, stripped of didactical intentions and presuppositions" (Brousseau, 1997, p. 229). The adidactical milieu consists, generally, of the task proposed to the students; of physical tools provided such as calculators, computers, hands-on material, exercise books, pencils, rulers, compasses, and so forth; of psychological tools such as texts, tables, notation, illustrations, diagrams, and so forth (psychological tools are frequently provided as part of the formulated task); and, of the arrangement of the classroom (organisation of desks and chairs, etc.). The adidactical milieu is independent from the teacher and the students (even if the teacher usually has prepared the adidactical milieu for devolution to the students).

The fact that different types of interaction with the milieu and different forms of knowledge are justified *a priori* allows the teacher or researcher to discuss the properties of the milieu which are necessary in order to provoke the interactions and knowledge aimed at. Questions like, "Why would the student do or say this rather than that?", "What must happen if he does or does not do it?" are suitable to expose important conditions on the milieu.

An influence of a didactical or adidactical situation on a student is in the theory of didactical situations called *feedback*. The student receives

this influence as a sanction to his action, which provides him with the opportunity to adjust that action; to reject or accept a hypothesis, to choose the optimal solution among several (Brousseau, 1997, p. 7). In a situation of *action*, it is the situation itself that provides feedback; that is, whether the student can solve the problem given to him (or, whether he understands what it means to solve it). In the terminology of game, the feedback in the situation of action is in terms of a win or lose (Brousseau, 1997, p. 9). In the situation of *formulation*, the feedback for a student is of two types: one is the feedback from other students in the group whether they, during the discussion, understand his suggestion of a strategy or formulation or not; the other is the feedback from the milieu, if his suggestion solves the problem (in the terminology of game: if the proposed strategy was a winning one or not; Brousseau, 1997, p. 11). In the situation of *validation*, the student is dealing with relationships between a “real” situation (concrete or not) and one or several statements formulated about the subject (or, activity) in this real situation (Brousseau, 1997, p. 15). The student must make statements about these relationships. The feedback in the situation of validation is in terms of an interlocutor’s (peer student’s) judgement of the statements put forward. This interlocutor must be able to protest, reject a reason which he judges false, give reasons, and try to prove it in his turn (Brousseau, 1997, p. 16).

#### **2.4.4 The milieu**

The concept of *milieu* models the elements of the material or intellectual reality on which the student acts and which may be an obstacle to his actions and reasoning (Laborde & Perrin-Glorian, 2005). As explained in Section 2.4.1, in the theory of didactical situations, teaching is envisaged as the devolution of a learning situation from the teacher to the student. In the devolution process, the teacher is faced with a system, itself built up from a pair of systems; the student and a milieu that lacks any didactical intentions with regard to the student (Brousseau, 1997, p. 40).

The milieu is a subset of the student’s environment with only those features that are relevant with respect to a given piece of knowledge (the environment is not relevant in all its complexity). As described in Section 2.4.1, an epistemological hypothesis in the theory of didactical situations is that each item of knowledge must originate from adaptation to a specific situation, referred to as a *fundamental situation*. Translated into a learning situation, this means that students do not invent or use algebra, for example, in the same context and relationship with the milieu as that in which they invent or use probability theory (Brousseau, 1997, p. 23).

The diagram in Figure 2.5 shows the structure of the didactical milieu in terms of the different roles of the student (S) and the teacher (T).

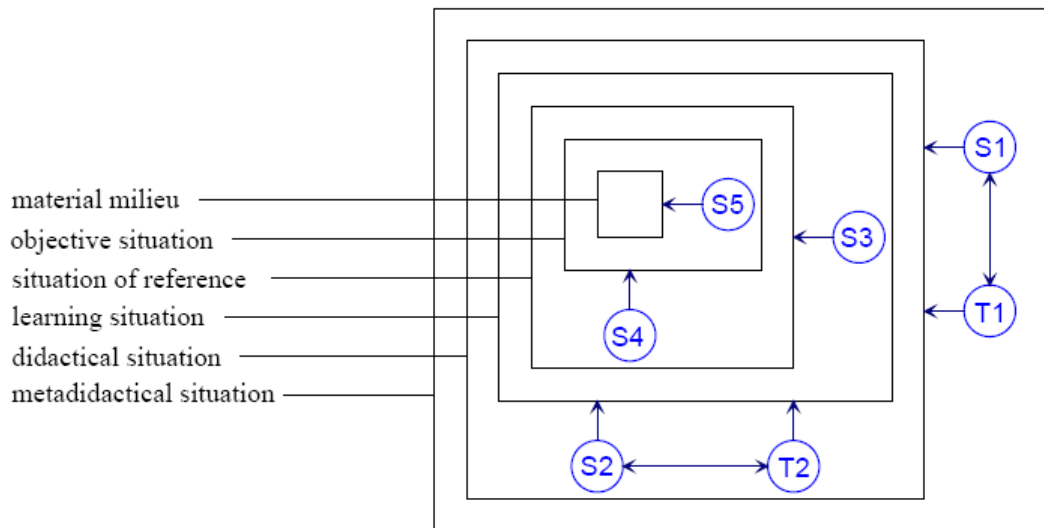

S1: the universal student who looks at a teaching situation from outside; S2: the student who looks at her own learning situation with whom T2 is discussing her (the student's) learning; S3: the subject as a learner; S4: the subject solving the mathematical problem; S5: an objective actor (person in the problem); T1: the teacher preparing her lesson; T2: the teacher teaching acts upon or observing the subject in the learning situation.

Figure 2.5. The different roles of the student (subject) and the teacher in the didactical milieu (adapted from Brousseau, 1997, p. 248)

A situation at one level in the diagram is a milieu for the next (outside) level (M.-J. Perrin-Glorian, personal communication, 15 June, 2009). Following Brousseau (1997) and Marie-Jeanne Perrin-Glorian (personal communication, 15 June, 2009), I give the following explanation of the structure of the didactical milieu: At the first (innermost) level there is the objective situation constituted by the mathematical problem. The milieu for the objective situation is the material milieu, that is, the “reality” described in the mathematical problem. In the material milieu there may be hypothetical persons (S5) acting (those described in the mathematical problem, referred to as “objective actors” by Brousseau).<sup>28</sup> Then, at the next level, the objective situation becomes a milieu (termed *objective*

<sup>28</sup> The material milieu does not necessarily include any actor.



*milieu* by Magali Hersant and Marie-Jeanne Perrin-Glorian, 2005) for a student (S4) who tries to solve the mathematical problem.

Then, at the next level, this situation (termed the situation of reference) becomes a milieu for a student (S3)<sup>29</sup> who reflects on the situation with the student (S4) trying to solve the mathematical problem. Then, at the next level, there is the didactical situation with a student (S2) and a teacher (T2) acting on this learning situation as a milieu. The outermost level is the metadidactical situation where the didactical situation is the milieu for the student (S1) and the teacher (T1) to act on; this is the level where the didactical contract is “negotiated”. In this way, each level refers back to the previous one in the sense that the previous level is the milieu for the present level.

The teacher designs a milieu (e.g., a mathematical problem) which reveals more or less clearly her intention of teaching to the student some particular knowledge. The teacher conceals enough of this knowledge and the expected answer so that the student can obtain them only by producing responses to the milieu, which are managed by the student’s existing knowledge. According to Brousseau (1997), the value of the acquired knowledge therefore depends on the quality of the milieu as an instigator of a “real”, cultural functioning of knowledge, and thus on the extent to which the knowledge is re-usable in different didactical situations not prepared by the teacher. Hence, the milieu can be described as the student’s “antagonist” system in the learning process, and knowings as properties of the interactions (relationships) between a student and the milieu (Brousseau, 1997, p. 61). The antagonist system is something that gives feedback and can help the students to adjust their actions, formulations, and conjectures.

I provide an example of a didactical situation to illustrate the concept of milieu. The example takes as a starting point the mathematical task presented in Figure 2.6. I will explain what constitutes the milieu in different types of situations related to the task.<sup>30</sup>

---

<sup>29</sup> Selections of the students (S1, S2, S3, and S4) who are actors in the didactical milieu may be the same person (they may all be the same person), but they may also all be different persons. T1 and T2 may or may not be the same person, as well.

<sup>30</sup> This rather long example is provided to help the reader understand the concept of *milieu* and to introduce him/her to the context of the mathematics (e.g., sequence, generic element, algebraic formula) that is fundamental to the analyses presented in Chapters 6, 7, and 8.

Example of task

Below you see the first three elements of a shape pattern intended to be continuing to infinity.

1
2
3

a) Draw the next element of the shape pattern presented above. What will the 10<sup>th</sup> element look like?

b) There is a relationship between the position of an element in the shape pattern and the number of circles in the different parts of the element. Try to illustrate this relationship by decomposition of elements (i.e., diagrammatic isolation by for instance encircling or painting with different colours). The decomposition shows the invariant structure of the shape pattern. Express in natural language what you see. What will the  $n$ -th element of the shape pattern look like?

c) Express the observed relationship between position and element in terms of a formula; this means to express the  $n$ -th member of the sequence mapped from the shape pattern as a function of its position. Argue that your formula is correct.

Figure 2.6. Task for algebraic generalisation of arithmetic relations in elements of a shape pattern

The target knowledge in the exemplified didactical situation is algebraic generalisation of arithmetic relations in elements of a shape pattern. The algebraic formula for the  $n$ -th member of the sequence mapped from the shape pattern is intended to be justified by identification of references between partitions of a generic element and algebraic symbols in the formula.

It is relevant to comment that the outline given below is just a sketch of a hypothetical didactical situation. The sketch does not include a description of all interactions between students, and between students and a teacher, which would be essential during the students' engagement with the objective situation (the mathematical problem).

*The situation of action and its milieu exemplified*

The situation of action involves the students' engagement with drawing of the particular elements (geometric configurations) asked for. Further, it involves the students' manipulation of the elements by decomposition (colouring with different colours, or other techniques) in order to experience a relationship between the position of an element and its numerical value (defined by its number of components). The milieu for the situation of action is the material milieu; that is, the image of the shape pattern and the parts of the task that address the students' drawing of new elements and manipulation of elements in order to illustrate the invariant structure of the shape pattern.

The outcome of the situation of action is the students' drawing of several elements and their illustration of a relationship between position and numerical value of elements. Figure 2.7 shows one of several possible decompositions that illustrate the invariant structure of the shape pattern presented in Figure 2.6.

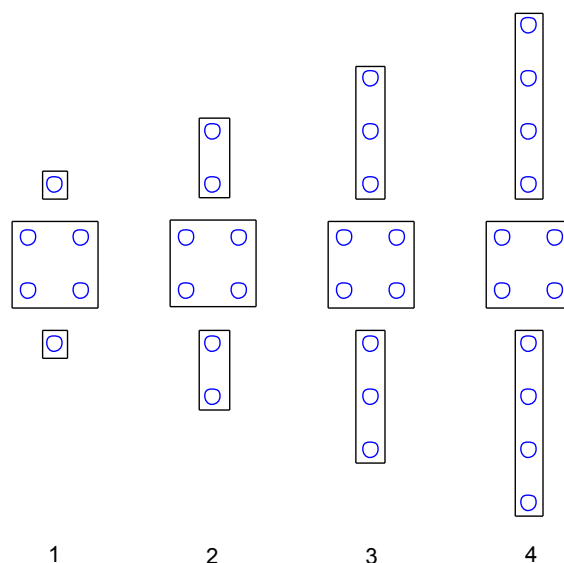

Figure 2.7. One of several possible decompositions of elements of the shape pattern presented in the example (Figure 2.6)

The students' observations of and first informal conjectures about a potential relationship between position and numerical value of elements (originated from the decomposition made) are also part of the outcome of the situation of action. Observations may include the following arithmetic relationships arising from the first four and the tenth elements:  $4 + 1 + 1$ ,  $4 + 2 + 2$ ,  $4 + 3 + 3$ ,  $4 + 4 + 4$ , and  $4 + 10 + 10$ .

*The situation of formulation and its milieu exemplified*

The situation of formulation involves the students' attempts to represent mathematically the informal conjectures about the invariant structure of the shape pattern (illustrated by the decomposition made). The milieu for the situation of formulation is the outcome of the situation of action as described above, in addition to part c of the task (see Figure 2.6 above), which addresses the formulation of the sought relationship.

The teacher expects that the students have observed that the number of circles in the two congruent rectangles of the elements is equal to the position of the elements in the shape pattern sequence. With respect to the circles in the middle (inside the square), the teacher expects that they have observed that it is constantly four.<sup>31</sup> The outcome of the situation of formulation is intended to be a formula in terms of something like  $f(n) = 4 + 2n$ ,  $a_n = 4 + 2n$ , or "the number of circles in the  $n$ -th element is equal to  $4 + 2n$ ".

*The situation of validation and its milieu exemplified*

The situation of validation involves the students' justification, in presence of and opposition to other students, that their conjectured formula is correct for all natural numbers. The milieu for the situation of validation is the outcome of the situation of formulation (a formula as described above), together with the requirement in the task (part d) to prove that the formula is always true.

It may be that the students argue by a strategy of guess-and-check; that their formula is true because it is correct for particular elements of the pattern (the ones drawn). It will be the teacher's role to encourage them to argue along the lines of a generic example (by using the decomposition to identify references between the number of circles in the dif-

---

<sup>31</sup> It may be that they have done some reasoning to find a relationship between position and number of circles in the middle of the elements. They may have observed the following regularity: For the first element, the number of circles in the middle is three more than the position; for the second, there are two circles more than the position, and so forth. For the tenth, there are six circles less than the position. Then this is the milieu for the students' formulation of the statement that the numbers composed in this way,  $1 + 3$ ,  $2 + 2$ ,  $3 + 1$ ,  $4 + 0$ , and  $10 - 6$ , are all equal to four. Hence, the relationship between position and number of circles in the middle is equal to four, independently of position in the shape pattern.

ferent partitions of the elements and the symbols in the conjectured formula). Another way would be to argue by a proof by induction.<sup>32</sup>

*The situation of institutionalisation and its milieu exemplified*

The situation of institutionalisation involves the teacher's record of what has happened in the preceding situations and her giving meaning to the students' actions and the knowledge developed. It involves among others the teacher's focus on the following: the connection between a decomposition<sup>33</sup> and its representation of an invariant structure; how arithmetic relations can be derived from a decomposition; identification of the position of elements in arithmetic expressions that represent the numerical values of elements; how arithmetic expressions of numerical values of elements are the basis for algebraic thinking where the variable has the role of placeholder for position; and, the notion of a generic example (how one decomposed element can be a representative for the whole class of elements). The teacher also informs about conventional terminology and notation (function notation, use of indexes, etc.).

Different from what is the case for situations of action, formulation, and validation, the milieu for the situation of institutionalisation is not only the outcome of the last situation; the milieu is the outcome of all the preceding situations. Institutionalisation of the formula that is established and justified by the students is not institutionalisation of the formula per se. It is institutionalisation of how it can be derived through identification of arithmetic relations in the elements and, further, generalised by algebraic reasoning on a generic example. The cultural, reusable knowledge in this case is the nature of the relation between the algebraic expression and its referent (a generic element of the shape pattern).

Through the example presented in Figure 2.6, I have illustrated the notion of milieu as it is manifested in situations of action, formulation, validation, and institutionalisation related to a didactical situation aimed at algebraic generalisation of a shape pattern. In the next paragraphs I

---

<sup>32</sup> An induction proof involves that it is observed that the conjectured formula is true for  $n = 1$ . Then it is assumed that it is true for  $n = k$ ; that is,  $f(k) = 4 + 2k$ . In the shape pattern presented in Figure 2.6, the difference between the numerical values of two consecutive elements is two. Therefore, it can be derived that  $f(k) + 2 = 4 + 2k + 2 = f(k + 1)$ , which shows that the formula is true also for  $n = k + 1$ . This proves the conjecture. It is obvious that the type of justification aimed at will depend on the grade at which the task is given.

<sup>33</sup> Students have probably made different decompositions.

use the same example to illustrate the structure of the didactical milieu in terms of the different roles of the students and the teacher.

*The different roles of the student and the teacher in the didactical milieu illustrated by the shape pattern example*

In the hypothetical didactical situation described above (related to the task presented in Figure 2.6), the first level of the didactical milieu (cf. Figure 2.5), termed the objective situation, is constituted by the mathematical task which aims at algebraic generalisation of a shape pattern. The material milieu for the objective situation is the shape pattern which is without any acting subject. At the next level, termed the situation of reference, the objective situation is the milieu for a student (S4) who tries to establish a formula for the general member of the sequence mapped from the shape pattern. At the next level, termed the learning situation, the situation of reference is the milieu for a student (S3) who reflects on the situation of reference. It is a learning situation for S3 where he reflects on S4's work (his decomposition of elements, the arithmetic relations expressed, the conjectured formula and its justification). It may be that S3 compares S4's work with other students' work and reflects on their achievements being different. S3 may wonder whether it is appropriate to establish the sequence of numbers  $\{6, 8, 10, 12, L\}$  mapped from the shape pattern and use it to establish the formula  $f(n) = 2n$  for  $n \in \{3, 4, 5, 6, L\}$ .

At the next level, termed the didactical situation, the learning situation (with S3 reflecting on S4's work) is the milieu for a student (S2) and a teacher (T2) to act on. At this level T2 both observes and acts on the learning situation. In the didactical situation, questions like the ones asked in the learning situation are discussed, and it is where T2 explains the status of the knowledge developed at the previous levels. This means for instance that T2 explains that the established formula is inevitably connected to the presented shape pattern and that its value lies in the nature of the connection between the decomposition and the algebraic symbols in the formula. Introduction of the notion of a generic example belongs to this level, together with a discussion of the validity of different types of reasoning.

At the last level, termed the metadidactical situation, the didactical situation is the milieu for a universal student (S1) and a universal teacher (T1) who reflect on the didactical situation. This is where the didactical contract is "negotiated", which means that T1 and S1 reflect on what kinds of interactions with the milieu will be required to foster students' algebraic thinking. Relevant questions at this level, originated from the provided example with the shape pattern, would be: "How can students be encouraged to argue by using generic examples?", "What must hap-

pen if a student reasons by naïve empiricism and writes the sequence of numbers  $\{6, 8, 10, 12, L\}$  mapped from the shape pattern and establishes the formula  $f(n) = 2n$  for  $n \in \{3, 4, 5, 6, L\}$ ?”

I have now presented the main elements of the theory of didactical situations in mathematics. In the next section I argue for the legitimacy of this theoretical framework in my study.

## 2.5 Legitimacy of the theory of didactical situations in this study

The objective of my study has been to identify relationships between, on the one hand, the didactical situations in which the participants of the study engaged, and, on the other hand, the target mathematical knowledge defined by the teacher who designed the situations. The reason I find the theory of didactical situations relevant and valuable in my research inquiry is that it is a framework that addresses the *problems* posed by the teaching and learning of mathematics (see Section 2.2). The theory emphasises epistemological and didactical analyses and its focus is on the nature and functioning of some particular mathematical knowledge. This is significant for my investigation of factors that constrain students' establishment of algebraic generality in shape patterns, where I define the small-group teaching situation as the unit of analysis when I examine the interplay between the teacher, the students and the mathematical knowledge at stake.

In the following I use the concept *regular* teaching situation in the sense that the teaching situation is not the result of didactical engineering. A relevant consideration is whether it is appropriate to use the theory of didactical situations to analyse episodes from regular teaching events. By this I refer to a potential tension between the teacher perspective and the researcher perspective in the sense that I have analysed the observed situations from a theoretical perspective not utilised by the teacher when he designed or engaged in those situations. I have used concepts and models from Brousseau's theory as analytical tools to conceptualise the triadic didactic relationship which binds the teacher, the students, and the mathematical knowledge in play. I have through the analyses of the empirical material identified relationships between the mathematical tasks and the teacher's interventions on the one hand, and the students' engagement with the tasks on the other hand. This identification is done from the perspective of an analysis of the target knowledge as being latent in the tasks and intended by the teacher. The identification is *not* done from the perspective of an evaluation of the tasks or the teacher's interventions according to concepts and models in Brousseau's theory.

It has not been my aim to design and test new didactical situations based on the analyses of the didactical situations observed. That would have been an endeavour of didactical engineering which would have involved alternative research questions to be investigated, and was outside the scope of my study. In the following I argue that it is legitimate to use the theory of didactical situations to study regular teaching situations. This I do with reference to Brousseau's more recent writing, and with reference to other studies in which the theory is used to analyse regular classroom situations.

With respect to the status of the theory of didactical situations, Brousseau wrote in an e-mail message to Anna Sierpinska in November 1999:<sup>34</sup>

The theory of situations is aimed to serve both the study and the creation of all kinds of learning and teaching situations, whether they are "spontaneous", or the product of an experience or of a special didactical engineering project, and whether they are efficient or not. It is not a method of teaching. The theory can provide some methods of teaching, it can justify some methods and disqualify some other methods, as the case may be. The theory contains models that may support certain plans of action aiming at making the students (re)discover some mathematics. This way the theory can make suggestions for engineering. (Brousseau, e-mail cited by Sierpinska, 1999<sup>35</sup>, Lecture 8, p. 1)

Didactical engineering can be considered the methodology of instructional design of the theory of didactical situations. Brousseau explains the relationship between the two:

Theory of situations has been elaborated to provide a framework for the study and means of description of any situation in which there is an intention of teaching someone some precise knowledge, whether it succeeds in it or not. It can take into account all the forms of learning identified in all kinds of research. The theory does not pretend to present all aspects of teaching situations and replace all the approaches: psychological, psychoanalytical, linguistic, statistical, etc. But it tends to put the contribution of these approaches in the perspective of their function and their generality in the description of "didactic phenomena". . . . Theory of situations is neither an ideology nor [a] particular didactic method. In this sense, it has no technical alternative. It does not directly recommend this or that particular didactic procedure. Its theoretical concepts only allow one, for

---

<sup>34</sup> The letter is translated into English by Sierpinska.

<sup>35</sup> Sierpinska writes that these lecture notes (Lectures 1-8) were given in the programme, "Master in the Teaching of Mathematics", at Concordia University in Montreal. They were part of the course MATH 645, in the autumn of the year 1999. Brousseau's book (Brousseau, 1997) was used as a textbook in the course. Retrieved from [http://annasierpinska.wkrib.com/index.php?page=lecture\\_on\\_tds](http://annasierpinska.wkrib.com/index.php?page=lecture_on_tds)



reasons of consistency, to predict the role of certain factors in some circumstances. (Brousseau, e-mail cited by Sierpiska, 1999, Lecture 8, p. 2)

Thus, Brousseau considers the theory of didactical situations as neither a method of teaching nor an ideology. Its strength lies in its utility to predict the role of certain factors in the didactical relationship between the teacher, the student and some particular mathematical knowledge. He emphasises that the theory is applicable as a framework for the study of *any* situation in which there is an intention of teaching someone some particular mathematical knowledge (and not just situations which are results of didactical engineering). This is consistent with how the theory is used by many researchers; to study regular classroom situations (see Laborde, Perrin-Glorian, & Sierpiska, 2005).

According to Colette Laborde and Marie-Jeanne Perrin-Glorian (2005), until around 1995, the notions of *milieu* and *didactical contract* were used mainly as tools for the design of didactical situations. Since then, however, partly under influence of Chevallard's anthropological theory of didactics, these theoretical concepts have become tools for analysing the activity of teachers and students in regular<sup>36</sup> classroom situations (Laborde & Perrin-Glorian, 2005). Laborde, Perrin-Glorian, and Sierpiska edited a collection of papers (Laborde, Perrin-Glorian, & Sierpiska, 2005)<sup>37</sup> which report from empirical studies analysed mainly within the frameworks of the theory of didactical situations (Brousseau, 1997) and the anthropological theory of didactics (Chevallard, 1992). In four of these papers, several concepts from the theory of didactical situations are used as analytical tools to study regular classroom situations. These papers are: Brousseau and Gibel (2005); Hersant and Perrin-Glorian (2005); Margolinas, Coulange, and Bessot (2005); and, Sensevy, Schubauer-Leoni, Mercier, Ligozat, and Perrot (2005). They are examples which illustrate that the theory of didactical situations has developed to have applicability beyond didactical engineering. The paper by Guy Brousseau and Patrick Gibel (2005) addresses the issue of a teacher using an open problem situation that does not provide an adidactical milieu for the students' prior knowledge. The papers by Hersant and Perrin-

---

<sup>36</sup> Laborde, Perrin-Glorian, and Sierpiska (2005) use the concept *ordinary* classroom situation in the same meaning as I use the concept *regular* classroom situation.

<sup>37</sup> The collection of papers that constitutes the book (Laborde, Perrin-Glorian, & Sierpiska, 2005) was first published as a special issue of *Educational Studies in Mathematics* (Volume 59, 2005).

Glorian (2005) and Sensevy et al. (2005) illustrate how the teacher organises an interplay between the didactical contract and the milieu in order to let students progress in the process of solving a mathematical problem. In the paper by Margolinas et al. (2005) the notion of milieu is extended to the learning potential of the teacher.

The aim of my study and the role I have taken as a researcher resonate well with the research reported by Hersant and Perrin-Glorian (2005):

The aim of the research is to gain knowledge and understanding of teaching phenomena; it is not to produce immediate action or to improve teaching in a direct way. Moreover, our project is not one of didactic engineering (Artigue, 1992; Artigue & Perrin-Glorian, 1991). Indeed the researcher intervenes neither in the design of teaching nor in its realization. (Hersant & Perrin-Glorian, 2005, p. 114)

The role of the researcher, both in my study and in Hersant and Perrin-Glorian's study, has been to observe and analyse regular teaching situations. In my study the observations were video recorded and transcribed, in Hersant & Perrin-Glorian's study the observations were audio-recorded and transcribed. Further, conversations with the teachers were conducted in both studies.

The theory of didactical situations in mathematics provides models and concepts that make it possible to analyse and communicate what is going on in the mathematics classroom in terms of the interplay between the students, the teacher, and some particular mathematical knowledge. Rather than a theory of learning, it is a scientific approach to the set of problems put forward by the teaching and learning of mathematics, in which the specificity of the knowledge taught plays a significant role (Brousseau, 2000). It is relevant, therefore, to complement Brousseau's theory with a theory of learning and development. Central in my utilisation of Brousseau's theory is the conceptualisation of didactical situations in mathematics as mediating between the students and some particular mathematical knowledge. Important in this conceptualisation is the construal of instruction of scientific concepts as didactical situations designed to teach and learn the target mathematical knowledge. This leads me to the Russian psychologist Lev S. Vygotsky's theory of learning and development as mediated processes.

In the next section I give a brief account of sociocultural theory as developed by Vygotsky and his successors where I focus on the notion of mediation and on concept development as an outcome of the interplay between spontaneous and scientific concepts.

## 2.6 Vygotsky's theoretical approach

Initial studies of cognitive development tended to ignore the context or to provide an incomplete view of the relationship between cognition and context (Daniels, 2001). Harry Daniels (2001) notes that since the 1980s the number of theoretical approaches which attempt to investigate the development of cognition in context using non-deterministic, non-reductionist theories has grown rapidly. Daniels mentions four main approaches within this category: sociocultural approaches (Wertsch, 1991; Wertsch, del Río, & Alvarez, 1995); cultural-historical activity theory (Cole, Engeström, & Vasquez, 1997); situated learning models (Lave, 1996); and, distributed cognition approaches (Salomon, 1993). According to Daniels (1996), the common feature of these approaches is that they build upon the writings of Vygotsky and use his theory as a tool to investigate and understand the processes of the social formation of mind.

There are three central theoretical notions within Vygotsky's account of learning and development as mediated processes (Daniels, 2007). First, the general genetic law of cultural development (Vygotsky, 1981b); second, the zone of proximal development (Vygotsky, 1978); and third, concept formation as an outcome of the interplay between spontaneous and scientific concepts (Vygotsky, 1934/1987). Vygotsky's principle of scientific concepts as the content of school instruction is an elaboration of Vygotsky's general theoretical view of mediated learning as the major determinant of human development (Kozulin, 2003). Brousseau's (1997) theory of didactical situations in mathematics expands on Vygotsky's theory of formation of scientific concepts in mathematics in the way Brousseau's theory provides insights into the premises for and nature of the instruction of scientific concepts.

James V. Wertsch, Pablo del Río, and Amelia Alvarez (1995) have a concise description of a sociocultural approach: "The goal of a sociocultural approach is to explicate the relationships between human action, on the one hand, and the cultural, institutional, and historical situations in which this action occurs, on the other" (p. 11). If human action is defined as students' reasoning and development of some particular mathematical knowledge, and the cultural and institutional situation in which this action occurs is interpreted as a didactical situation in Brousseau's terms, the description by Wertsch et al. (1995) can be used to conceptualise the relationships between students' development of some particular mathematical knowledge and the didactical situation in which this development occurs, in terms of sociocultural theory. Explication of the mentioned relationship within sociocultural theory is, as stated above, based on the comprehension of a didactical situation as mediating between the students and some particular mathematical knowledge. This will be explained further in Sections 4.1 and 4.2.

Wertsch (1985) claims that there are three themes that form the core of Vygotsky's theoretical framework: 1) The reliance on a genetic<sup>38</sup> or developmental method; 2) the claim that higher mental processes in the individual originate from social processes; and 3) the claim that mental processes can be understood only if we understand the tools and signs that mediate them (pp. 14-15). These themes are, according to Wertsch, interrelated with each other: The notion of origins in the second theme presupposes a genetic analysis, and Vygotsky's account of social interaction and mental processes depends to a great extent on the forms of mediation (such as language) involved. Wertsch argues that the theme concerning tool and sign mediation is analytically prior to the other two; Vygotsky's claims about mediation can generally be understood on their own grounds, whereas the other two can be understood only if the notion of mediation is called upon.

The three theoretical notions characterised by Daniels (2007) as central in Vygotsky's explanation of learning and development as mediated processes (presented above) and the three themes identified by Wertsch (1985) as constituents of Vygotsky's theory (presented in the previous paragraph) are interrelated: The claim that higher mental processes in the individual originate from social processes, together with reliance on the genetic method, leads to an articulation of the general genetic law of cultural development. Further, the zone of proximal development and concept formation as an outcome of the interplay between spontaneous and scientific concepts are conceptualisations of the process of mediation as manifested in instructional settings. Vygotsky (1934/87) refers to spontaneous concepts as concepts acquired by the child outside contexts in which explicit instruction is carried out, whereas scientific concepts are referred to as introduced by a teacher in school.

In the next section I explain the notion of mediation in Vygotsky's theory.

### **2.6.1 Mediation**

Wertsch et al. (1995) note that claims about how (technical) tools and signs (psychological tools) mediate human action became increasingly important for Vygotsky near the end of his life and career. This point is

---

<sup>38</sup> The term "genetic" is used by Wertsch "in connection with developmental processes (as in ontogenetic or phylogenetic) rather than with genes, genetic codes and the like" (Wertsch, 1985, p. 234, note 10).

reflected in Vygotsky's 1933 remark that "the central fact about our psychology is the fact of mediation" (Vygotsky, 1982, as cited in Wertsch et al., 1995, p. 20). Wertsch et al. (1995) refer to Vygotsky's theory of semiotic mediation and Leontèv's theory of activity (Leontèv, 1981), when they claim that the notions of "mediational means" and "mediated action" have emerged as constitutive building blocks in the formulation of sociocultural research.

A clarification of the notion "to mediate" is expressed through the following formulation by Wertsch et al. (1995): "An underlying assumption of [sociocultural] research is that humans have access to the world only indirectly, or *mediately* [emphasis added], rather than directly, or immediately" (p. 21). According to Wertsch (1994), mediational means or cultural tools provide the link between the concrete actions, including mental action (e.g., reasoning and remembering) carried out by individuals and groups on the one hand and cultural, institutional, and historical settings on the other. Wertsch asserts that "the relationship at issue here between human action and sociocultural setting is not one of unidirectional causality" (p. 203). He maintains that in order to provide an account of human action, it is necessary to take into account the cultural, institutional, and historical setting. On the other hand, such settings are produced and reproduced through human action (Wertsch, 1994).

Vygotsky (1978, 1981a) viewed the introduction of a psychological tool (e.g., algebraic symbols) into a mental function (such as reasoning) as provoking a fundamental transformation of that function. This feature of psychological tools is central to Vygotsky's genetic analysis of mental processes. He viewed development not as a regular stream of quantitative increments but in terms of fundamental qualitative transformations associated with changes in the psychological tools (Wertsch, 1985).

Vygotsky (1981a) claims that psychological tools are artificial formations which by their nature are social, not organic or individual. He explains their role by presenting an analogy with technical means (also referred to as labour tools): "[Psychological tools] are directed toward the mastery or control of behavioural processes – someone else's or one's own – just as technical means are directed toward the control of processes of nature" (p. 137). He gives the following examples of psychological tools and their complex systems: "language; various systems for counting; mnemonic techniques; algebraic symbol systems; works of art; writing; schemes, diagrams, maps, and mechanical drawings; all sorts of conventional signs; etc." (Vygotsky, 1981a, p. 137).

In Vygotsky's approach, "the mediational means are what might be termed the 'carriers' of sociocultural patterns and knowledge" (Wertsch, 1994, p. 204). Wertsch (1994) asserts that Vygotsky tended to focus on the process of mastering existing mediational means and that he said rel-

atively little about how active use of them transforms meanings and mediational means and how it gives rise to new ones.

In the next section I explain Vygotsky's perspective on the relationship between spontaneous and scientific concepts where I focus on the role of instruction.

### **2.6.2 Instruction and development of scientific concepts**

Theories about the relationships between thought processes, concept development and social communication, including instruction, are central to any educational project (Daniels, 2001). Vygotsky claims that specific ways of using words is a necessary part of the process of concept development: "The concept is not possible without the word. Thinking in concepts is not possible in the absence of verbal thinking" (Vygotsky, 1934/1987, p. 131). For Vygotsky, content learning is associated with two different conceptual processes: the formation of *spontaneous* or everyday concepts and the formation of *scientific* concepts. Spontaneous concepts are acquired outside contexts of explicit instruction, and are formed on the basis of identifying common characteristics of empirical events or objects (Vygotsky, 1934/1987). Spontaneous concepts are un-systematic, not conscious, and often wrong in the sense that they are based on some observed properties whereas the concept at stake requires other properties to be fulfilled. For example, a 3-year old child having observed that a needle, a pin, and a coin are sinking in water, arrives at the wrong conclusion that "all small objects sink" (Zaporozhets, 1986, as cited in Karpov, 2003). The conclusion is wrong in the sense that it is not consistent with the fact that for instance a small piece of wood does not sink in water. Scientific concepts, on the other hand, represent the generalisation of the experience of human kind that is fixed in science; in natural and social sciences as well as in the humanities (Karpov, 2006). Scientific concepts are introduced by the teacher inside contexts of explicit instruction, and correspond to scholarly, systematic reasoning in the sciences (Vygotsky, 1934/1987).

In the process of development of scientific concepts, the need for instruction is fundamental (Daniels, 2001; Karpov, 2003). This is associated with the institution of the school and the teacher: "The fundamental difference between the problem which involves everyday concepts and that which involves scientific concepts is that the child solves the latter with the teacher's help" (Vygotsky, 1934/1987, p. 216). In instructional contexts, the word assumes a function which is different from that in everyday contexts. "[In instructional contexts] the word begins to function not only as a means of communication but as the object of communicative activity" (Minick, 1987, p. 27). This new function of the word, Vygotsky (1934/1987) asserts, leads to the development of scientific concepts.

Vygotsky (1934/1987) presents an interconnected model of the relationship between scientific and spontaneous concepts, and describes the way the two types of concepts contribute to each other:

The formation of concepts develops simultaneously from two directions, from the direction of the general and the particular. . . . The development of scientific concepts begins with the verbal definition. As part of an organized system, this verbal definition descends to concrete; it descends to phenomena which the concept represents. In contrast, the everyday concept tends to develop outside any definite system; it tends to move upwards toward abstraction and generalization. . . . The weakness of the everyday concept lies in its incapacity for abstraction, in the child's incapacity to operate on it in a voluntary manner. . . . In contrast, the weakness of the scientific concept lies in its verbalism, in its insufficient saturation with the concrete. (Vygotsky, 1934/1987, pp. 163, 168-169)

Vygotsky's claim that the development of scientific concepts *begins with the verbal definition* ascribes to the teacher an important role as responsible for saturation of scientific concepts with the concrete, and for abstraction of spontaneous concepts. This is compatible with the teacher's role in the situation of institutionalisation in Brousseau's (1997) theory, where the teacher has the role of a representative of the official curriculum: The teacher records what the students have done in the preceding situations; she describes what has happened related to the knowledge in question and gives it meaning. Further, she informs the students about accepted terminology, and highlights definitions and theorems considered important for the contextualised knowledge to gain the status of cultural, decontextualised knowledge that can be re-used in settings other than the one originally set up. Institutionalisation involves two acts by the teacher: first, that she takes responsibility for an object of teaching and identifies its status as manifested in the processes and products of the students' engagement; second, that she "bring[s] these products of knowledge closer to others (either cultural or linked to the curriculum), and indicate[s] that they could be used again" (Brousseau, 1997, p. 236).

As commented by Wertsch (1984), Vygotsky never specifies the nature of instruction of scientific concepts beyond general characteristics in terms of cooperation between adult and child and assistance by the teacher determined by the child's zone of proximal development. In this respect, Brousseau's theory of didactical situations is valuable in the way it describes the role of the teacher related to the instruction of some particular mathematical knowledge.

In the next section I argue that Brousseau's theory of didactical situations, as I understand it as articulated today, is compatible with sociocultural theory as developed by Vygotsky and his successors.

## 2.7 Compatibility of Brousseau's theory and Vygotsky's theory

In this section I draw attention to statements in Brousseau's theory which I interpret as indications that it was necessary for him, in the course of development of the theory, to go beyond a mere cognitive approach and take the broader context into consideration. I show how Brousseau started within a constructivist frame but experienced that it was not sufficient to observe individuals isolated from activity because he wanted to study the relationship between the designed situation and the knowledge produced.

### 2.7.1 Starting within a constructivist frame

Brousseau started to develop the theory of didactical situations in the early 1970s. The theory was consistent with what was later referred to as (non-radical) constructivism (Artigue, 1992; Brousseau, Brousseau, & Warfield, 2004). As explained in Section 2.2.1, mathematical concepts are constructed in course of a history which follows another ordering than the logically-deductive ordering in which mathematicians present the knowledge they have developed (cf. the logic of mathematical discovery as conceptualised by Imre Lakatos, 1976). Mathematical concepts are constructed on the basis "of questions, of problems, and of solutions, where a much richer collection of 'reasons' comes into play" (Brousseau et al., 2004, p. 4). Brousseau et al. (2004) explain that the motivation for the development of the theory of didactical situations was that Brousseau wanted to realise, in the classroom, a process of construction of concepts important to the school curriculum which simulated as well as possible that sort of genesis. The goal was "to simulate a process making minimal use of pieces of knowledge imported by the teacher for reasons invisible to the students. This type of project was subsequently labelled constructivist" (Brousseau et al., 2004, p. 4).

Constructivism as an epistemological position influenced didactics of mathematics from the early 1970s, and generated a lot of research into children's processes of acquiring notions of for example, natural numbers, fractions, arithmetic operations, and exponential function (e.g., see Steffe & Gale, 1995). A certain "ideal" of teaching mathematics was developed, where there was no lecturing, no drill exercises, but individual children constructing their own knowledge by problem solving, without any intervention from the teacher (cf. Piaget's view on teaching referred to in Section 2.4.3). The hypothesis was that by *adapting* to a stimulating environment with interesting problems, children's cognitive structures would evolve in a natural way. Ernst von Glasersfeld (1995) uses the metaphor of a biological organism that changes through adaptation to its environment:



From the constructivist perspective, as Piaget stressed, knowing is an adaptive activity. This means that one should think of knowledge as a kind of compendium of concepts and actions that one has found to be successful, given the purposes one had in mind. This notion is analogous to the notion of adaptation in evolutionary biology, expanded to include, beyond the goal of survival, the goal of a coherent conceptual organization of the world as we experience it. (von Glasersfeld, 1995, p. 7)

Thus, from a constructivist perspective, knowledge is a psychological entity; an individual's network of cognitive structures and schemas. According to von Glasersfeld's (1995) radical constructivism, objectivist notions such as "truth" and "validity" of knowledge, which refer to a correct representation of reality, make no sense. They are replaced by the notion of "viability"; the ability of an organism to survive in its environment.

Artigue wrote in 1992 that "the didactics of mathematics in France has become based on constructivist theories of knowledge, greatly influenced by the approach of the Geneva school of psychology" (Artigue, 1992, p. 53). In her account of the teacher's role within didactical engineering, Artigue (1992) observes that it was the teacher who "paid the price" at the modelling and theorising level, for the exceptional role of the student (as "the most urgent task") in the early development of didactics within the constructivist framework:

Whereas situations of action, formulation and validation have been present right from the start of the theory of situation, situations of institutionalisation were only introduced much later since they could not be easily integrated within the usual modelling of situations. (p. 53)

As indicated by Artigue (1992), constructivism imposed a relatively strict limitation on the complexity that could be scientifically handled in didactics of mathematics. Because Brousseau became interested in the relationship between a didactical situation and the particular knowledge it aims at generating, he needed to extend Piaget's work (Brousseau, 2000). I argue below that what Brousseau terms "extension" of Piaget's work, can be interpreted to mean a departure from constructivism towards a sociocultural perspective on the activity of knowledge generation in an institutionalised setting.

### **2.7.2 Studying relationships between experiments on children's cognitive development and particular pieces of knowledge**

Brousseau (1997) holds a view on teaching, learning, and knowledge which is very different from von Glasersfeld's (1995) view. Brousseau claims that the notion of learning by adaptation is inconsistent. "In some ways, adaptation contradicts the idea of the creation of new knowledge" (Brousseau, 1997, p. 45). He provides this example: If a student solves a problem different from all the problems he has solved so far, with some adaptation of the knowledge he already has, he may think that he has not

invented some new knowledge. But if he shows his solution process to another student who has also tried to solve it, but was not able to (even if he presumably had the same prior knowledge), then the first student might infer that he has actually invented some new knowledge.

Brousseau (2000) writes that in the 1960s, while he was still a student of mathematics and also studying cognitive psychology with Pierre Greco,<sup>39</sup> he was impressed by Greco's cleverness in arranging experiments to expose the originality of children's mathematical thinking and the stages in their cognitive development. But he noted that Greco "made no effort to analyze the design of the experiments that he invented and to make explicit the relationships between this design and the mathematical notion whose acquisition was being studied" (Brousseau, 2000, p. 4). Brousseau was interested in studying the experiments themselves and their relationship to particular pieces of knowledge: "[Under] what conditions could a subject – any subject be induced to need this knowledge to make decisions, and why, *a priori* would he do it?" (Brousseau, 2000, p. 5). Brousseau wanted to find out how research could produce information about the acquisition of knowledge that was connected with some *generality*, and found out that "the children's behaviours are what reveal the functioning of the milieu considered as a system: the black box is thus the system" (p. 5).

According to Mary S. Weldon (2000), learning is in a cognitive psychological approach understood as taking place in the mind, and the goal is to build and test models of levels of individual mental processes that can be generalised across people. In order to understand these processes in pure form, experiments are isolated from activity and individuals are isolated from others (Weldon, 2000). Because Brousseau set out to reveal the functioning of the milieu considered as a system (i.e., to reveal the relationship between the designed situation and the knowledge produced), it was not sufficient to observe individuals isolated from activity. Hence, he needed to detach from Piaget's theory. Brousseau (personal communication, 3 January, 2007)<sup>40</sup> explains why he departed from Piaget:

---

<sup>39</sup> Greco, P. (1991). *Structures et significations*. Paris, France: EHESS.

<sup>40</sup> In an attempt to get a deeper understanding of the theory of didactical situations, I communicated among others with Luc Trouche. I asked for recommended sources which might help me understand the philosophical roots of Brousseau's theory. Trouche translated and forwarded my request to Brousseau, who answered by an extended explanation, referred to

Piaget revealed a universe, but the weakness in his approach with respect to the analysis of the devices and role of the cultural environment and the weakness in his capacity to analyse the mathematics and its functioning, together with his excessive emphasis on psychological interpretation of learning, made me detach from him progressively. (G. Brousseau, personal communication, 3 January, 2007)

To the question about philosophical roots of the theory of didactical situations, Brousseau explains that it is not possible to give an exact answer. He expresses that he has been influenced by a lot of French scientific works, and acknowledges that the French philosopher Gaston Bachelard was a revelation for him. Bachelard's (1938/2001) notion of *epistemological obstacle* is incorporated into the theory of didactical situations: "The identification and characterization of an obstacle are essential to the analysis and construction of didactical situations" (Brousseau, 1997, p. 77).<sup>41</sup> However, Brousseau (personal communication, 3 January, 2007) would rather not categorise any of the theories that inspired him as his philosophical roots, because he has made what he considers extensive changes and adaptations to them all. He emphasises further that his whole cultural background has stimulated him, though in terms of personal knowledge rather than scientific knowledge. This is recognised in his theory for instance by conceptualisations of phenomena which have been inspired from the literature (e.g., the Topaze and Jourdain effects, and Diderot's paradox of acting).

Brousseau (personal communication, 3 January, 2007) claims that there is no arrogance behind his apparent lack of interest in or acknowledgement of English sources, a condition he explains by two factors: First, by the linguistic barrier caused by late French translations of English scientific literature; second, by the deep epistemological differences between the two cultures. Due to late translations, he discovered much later what he experienced as a close relatedness between Ludwig Wittgenstein's and his own epistemological ideas (e.g., Wittgenstein, 1978).

---

as (G. Brousseau, personal communication, 3 January, 2007). Brousseau's explanation (in French) has been translated into Norwegian by Arne Amdal. Excerpts from the text used in this dissertation have been translated from Norwegian into English by me.

<sup>41</sup> The notion of epistemological obstacle is important in the theory of didactical situations because, "as results of learning by adaptation, knowings constructed by students are more often than not local and linked to other knowings in a 'contingent and unjustified' way. They are also temporary and incorrect" (Perrin-Glorian, 1994, as cited in Brousseau, 1997, p. 77).

### *Conditions for appearance and use of thought as Brousseau's unit of analysis*

At the time Brousseau started his research on mathematics teaching and learning, a common teaching method was the Diénès approach (see Section 2.3.6). This approach implied that the teacher communicated to the student the conditions and properties of a generating system so the student could produce the intended knowledge (formulae, theorems, etc.) by exercising rules which had been taught him (Brousseau, 2000). Brousseau (2000) writes that he, however, questioned the predictability of this approach. He wanted to know about the relationship between the function of the particular mathematical knowledge and the student's response: "In these conditions, the question which, repeated for every proposition envisaged, engendered the [theory of didactical situations] was 'Why?': why should a subject do this rather than that? Why does this knowledge demand that behavior?" (Brousseau, 2000, p. 5). These questions had some implications for the choice of unit of analysis in the theory:

The conditions for the appearance and use of thought are our black box, and the behaviors of the students and the teacher are what reveal them. Consequently, a didactical project must begin with its objective. It is the nature and function of knowledge that is the mainspring of its comprehension, use, and learning. (Brousseau, 2006, p. 6)

The concrete studies in the theory of didactical situations (e.g., the study of teaching of decimal numbers, Brousseau, 1997, Chapter 4) indicate under what precise conditions the teaching of a particular notion is possible in a particular form, and, further, that these conditions are never extreme (Brousseau, 2000, p. 19). According to Brousseau (2000), the conclusion of these studies is that in most cases, didactical interventions are regulations specific to the mathematical notion, which are predetermined to maintain equilibrium rather than to produce effects directly.

Brousseau (2000) explains that his experiments made him refuse radical constructivism as a theory because of what he interpreted as the theory's lacking potential to explain the student's learning of a predetermined mathematical knowledge: "The most spectacular consequence of the theoretical studies of the didactical contract has been to show that radical constructivism cannot lead to the acquisition by the student of knowledge aimed at, without didactical interventions" (Brousseau, 2000, p. 19). This can be exemplified by conditions for students' development of an attitude of proof, as outlined in Section 2.4.3 (the situation of validation); the aim of conviction and the notion of truth imply that construction of mathematical knowledge is primarily a *social activity*. The origin of meaning of proof is found in the practice of *doing* mathematics;

it is the student-milieu system that can make proof indispensable as a means of convincing others of the validity of a conjecture.

*Learning construed as a social activity: Aiming at cultural knowledge*

Brousseau (1997) questions why it is necessary to introduce a milieu-system into the learning situation:

Isn't learning essentially an individual act? Is it necessary to place it in such a large context in order to understand it? . . . Why isn't the possession of knowledge itself, together with general knowledge from the social sciences, some common sense and, of course, some pedagogical skills that no training can truly produce, sufficient for all teachers with all students, as it is for a few? (Brousseau, 1997, p. 24)

The psychogenetic Piagetian process is the opposite of scholastic dogmatism; the former is characterised as owing nothing to didactical intention, whereas the latter owes everything to it (Brousseau, 1997). The psychogenetic Piagetian process is characterised by the individual student who internalises his manipulations of physical objects into mental structures, without the teacher's intervention. Scholastic dogmatism is characterised by the teacher lecturing established facts. The theory of didactical situations proposes a methodology that presupposes that the student neither can appropriate the school mathematical knowledge through a psychogenetic Piagetian process, nor can he appropriate the school mathematical knowledge as a result of scholastic dogmatism. The methodology proposed in the theory of didactical situations identifies two main roles of the teacher (in addition to managing the evolution of the didactical situation); devolution and institutionalisation, as explained in Section 2.2.1. These roles deal with how the teacher can organise situations which make it possible and meaningful for the student to appropriate some particular cultural, re-usable mathematical knowledge. The need to introduce a milieu-system into the student's learning situation is, according to Brousseau (1997), neither a reification of the model (the instruments of the didactical situation) nor the product of an observation, but that of an internal necessity (p. 47). This means that the introduced milieu is necessary for *epistemological reasons* – based on the mathematical knowledge it aims at.

The main issue in the theory is therefore the necessary *conditions* for a situation to generate the particular mathematical knowledge aimed at. Questions like “Why would the student do or say this rather than that?”, “What must happen if she does or doesn't do it?” are central in the teacher's organisation of the student-milieu system (Brousseau, 1997, p. 65). Brousseau (1997) asserts that the teacher must make sure that each student finds whom to speak to and what to act on in the classroom, thus including a rationale that makes the engagement with the problem situa-

tion sensible for the students. The importance of communication and the rationale of action being located in the situation are features of the theory of situations that suggest that learning mathematics in the classroom is a *social activity*.

Brousseau (1997) points at the importance of the teacher in organising situations that can realise the student's acquisition of cultural mathematical knowledge:

By attributing to “natural” learning what is attributed to the art of teaching according to dogmatism, Piagetian theory takes the risk of relieving the teacher of all didactical responsibility; this constitutes a paradoxical return to empiricism! But a milieu without didactical intentions is manifestly insufficient to induce in the student all the cultural knowledge that we wish her to acquire. (Brousseau, 1997, p. 30)

The cultural knowledge here talked about I interpret to mean accepted semiotic means (notation, graphs, figures, etc.), concepts and relevant theorems that the teacher provides as a means of institutionalising the ideas and models that the students have constructed as a result of engaging with a mathematical problem in the classroom context. It is relevant here to draw on Vygotsky's theory of scientific concepts where he points at the importance of the teacher in providing the verbal definition of a scientific concept. The theory of didactical situations in mathematics provides models of the classroom interactions that need to precede the introduction of the verbal definition of a scientific concept. These interactions, taking place in situations of action, formulation, and validation, are necessary for epistemological reasons relative to the scientific concept aimed at. Further, the theory of didactical situations provides a model of the conditions under which the verbal definition of a scientific concept is possible; that is, the situation of institutionalisation.

*Didactical situations as mediating between the student and mathematical knowledge*

Brousseau (1997, Chapter 4) describes didactical problems with decimals and presents a fundamental situation with the thickness of a sheet of paper aiming at the students' conceptualisation of rational numbers as measurements. He explains that the students during their engagement in the didactical situation have compared thicknesses and found equivalent pairs of sheets of paper, and points out that this knowledge is dependent of the situation in which they have been engaged:

The children know how to find equivalent pairs. They know how to compare the thickness of sheets of paper (many of them using two methods). Using these comparisons, they have a strategy for ranking pairs. They know how to designate the thickness of a sheet of paper by means of a fraction and how to find equivalent fractions. They do not know how to find the equality of two fractions in the general case.

Remark: This know-how occurs within situations. It is not yet possible to take a question out of context and ask it independently. The results can not yet be depended upon as “acquired” knowledge, nor do the children identify them as such. (Brousseau, 1997, p. 204)

The remark in this quotation can be interpreted to have resemblance with the theory of *situated learning* as conceptualised by Jean Lave and Etienne Wenger (1991). In the theory of didactical situations, a piece of mathematical knowledge is represented by a *situation* which comprises a problem whose optimal solution is the target mathematical knowledge. Bosch et al. (2005) claim that teaching and learning mathematics is in the theory of didactical situations not considered as teaching and learning mathematical ideas or concepts, but as “teaching and learning a *situated human activity* performed in concrete institutions” (p. 1256). Further, they note that a *situation* includes the rationale that gives sense to the performed mathematical activity. This implies that the central question in the theory of didactical situations is: “What are the necessary conditions for a situation to implement the specific mathematical knowledge it defines?” (Bosch et al., 2005, p. 1256).

In this section I have argued that Brousseau’s theory, which in its beginning was consistent with (trivial) constructivism, has developed to take the broader context into consideration. It is relevant, therefore, to question whether the theory is a kind of social constructivism. My interpretation, however, that the source of meaning of the target mathematical knowledge is identified *in* the didactical situation, is consistent with a sociocultural perspective. In social constructivism, the source of meaning is identified in the cognising individual (Lerman, 1996). The didactical situation mediates between the student and the mathematical knowledge aimed at. In this way a didactical situation is a mediational means which, in Wertsch’s words, is a carrier “of sociocultural patterns and knowledge” (Wertsch, 1994, p. 204).

## 2.8 Summary

In this chapter I have presented Brousseau’s theory of didactical situations in mathematics as the framework of my study. I have explained how the theory enables relationships to be identified between didactical situations and the target mathematical knowledge defined for the situations. Analyses of the empirical material will be presented in Chapters 6, 7, and 8.

Brousseau’s theory is a scientific approach to the set of problems put forward by the dissemination and transposition of mathematics, in which the specificity of the target knowledge plays a significant role (Brousseau, 2000). Because it is not a theory of learning, it is relevant to complement the theory with a theory of learning and development. In order

to conceptualise learning as a social activity and to theorise the teacher's role in the didactical situation (particularly as defined in the situation of institutionalisation) it is necessary to go beyond constructivism and interpret didactical situations from a social perspective. I have argued in this chapter that the theory of didactical situations is compatible with sociocultural theory of learning and development as conceptualised by Vygotsky and his followers.

In the next chapter I present a theoretical foundation for algebra as generalisation of patterns, and a literature summary of empirical studies in which a pattern-based approach to algebra is used.



### 3 Theoretical foundation for a pattern based approach to algebra

The purpose of this chapter is to build a theoretical foundation for pattern generalisation from an algebraic perspective, and to provide a summary overview of reports from empirical studies in which a pattern-based approach to algebra is utilised.

Section 3.1 presents a content analysis of algebra as a discipline in mathematics, where algebra is defined as a complex composite organised around five interrelated forms of reasoning (Kaput & Blanton, 2001a). Section 3.2 presents an outline of a distinction between algebra as generalisation of patterns and algebra as generalised arithmetic. These two forms of reasoning constitute two different approaches to algebra (Balacheff, 2001; Radford, 1996). Section 3.3 provides a closer look at algebra as pattern generalisation and presents alternative definitions of algebraic thinking. A summary overview of reports from a pattern-based approach to algebra is presented in Section 3.4. Section 3.5 is about promoting algebraic thinking in students, where an “algebrafying” strategy for helping teachers to foster and sustain algebraic thinking in students is presented. Section 3.6 presents observations from some researchers about the teacher’s role in students’ algebra learning. The chapter closes in Section 3.7 with a brief outline of the relevance of research on students’ generalisation of patterns for my research inquiry.

#### 3.1 A content analysis of “algebra”

Al-Khwārizmī’s work on elementary algebra, *al-Kitab al-mukhtasar fi hisab al-jabr wa'l-muqabala* (“The Compendious Book on Calculation by Completion and Balancing”), in ca. 825, was translated into Latin in the 12th century, from which the title and term “algebra” derives (Al-Khwārizmī, n.d.). Algebra appeared in this work as a collection of rules, together with demonstrations, for finding solutions of linear and quadratic equations based on intuitive geometric arguments. Algebra is derived from problems of *al-jabr*, which literally means adding or multiplying both sides of an equation by the same number in order to eliminate negative and fractional terms, and from problems of *al-muqabala*, which means subtracting the same number from both sides or dividing both sides by the same number (Mason, 1996, p. 73).

James J. Kaput and Maria L. Blanton (2001a) claim that a broader and deeper view of algebra than algebra as primarily syntactically-guided, symbolic manipulations is needed, in order to support the integration of algebraic thinking across all grades and all topics of school mathematics. Drawing on Kaput (1995, 1998, 1999), Kaput and Blanton

(2001a) assert that algebraic thinking is a complex composite organised around five interrelated forms, or strands, of reasoning:

1. *Algebra as Generalising and Formalising Relationships and Constraints.*<sup>42</sup>

Two subcategories can be identified within this strand: The first subcategory involves generalised arithmetic, where the focus is on properties of the number system (e.g., commutativity, inverse relationships, etc.). The second subcategory involves generalisations established about particular number properties or relationships (e.g., sum of odd numbers is even, and finding regularities in the multiplication tables).

2. *Algebra as Syntactically-Guided Manipulation of Formalisms.* This strand includes among others factoring and simplifying algebraic expressions, where simplifying involves collecting like terms.
3. *Algebra as the Study of Structures and Systems Abstracted from Computations and Relations.* This strand includes reasoning and generalising with more abstract objects and systems, such as for instance matrices and groups.
4. *Algebra as the Study of Functions, Relations, and Joint Variation.* This strand includes generalising from numerical and geometric patterns, typically to provide function descriptions for dependent variation, but also to provide descriptions of recurrence relations; how the next member of a sequence can be described in terms of the current member.
5. *Algebra as a Cluster of Modelling and Phenomena-Controlling Languages.* This strand encompasses two different kinds of generalisation: The first kind involves generalising patterns and regularities built from mathematised situations or phenomena, where the generalisation is supposed to be about the *situation* or *phenomenon*. The second kind involves generalising from solutions to single-answer modelling problems by relaxing the constraints of the given problem

---

<sup>42</sup> Kaput and Blanton (2001a) refer to the first category as “Algebra as generalising and formalising patterns and constraints”. I have, however, referred to it as “Algebra as generalising and formalising *relationships* and constraints”. That is, the notion “patterns” is replaced by “relationships”. This is done in order to distinguish Kaput and Blanton’s first and fourth categories. The fourth category includes algebra as generalising spatial or numerical patterns, to which I will come back in the next section where I present a distinction between two approaches to algebra; algebra as pattern generalisation and algebra as problem solving.

to explore its more general form, scope and deeper relations – including comparison with other models and other situations. I offer the following example of algebra used in the sense of phenomenon-control: When a model of monthly compound interest on capital is explored to yield continuous compound interest, algebra is used in the meaning of phenomenon-control. With continuous interest the length of the compounding period, which is the variable, is reasoned to be infinitely small. The interest, therefore, is compounded continuously.

Kaput and Blanton (2001a) claim that the listed categories emphasise algebra's deep, but varied, connections with all of mathematics. The categories appear in various reform documents, for example Principles and Standards for School Mathematics (National Council of Teachers of Mathematics, 2000).

In the next section I describe a distinction between two approaches to algebra: algebra as generalisation of patterns, which falls under Kaput and Blanton's (2001a) category *Algebra as the Study of Functions, Relations, and Joint Variation*; and, algebra as generalised arithmetic, which falls under Kaput and Blanton's category *Algebra as Generalising and Formalising Relationships and Constraints*.

### **3.2 Two approaches to school algebra: Pattern generalisation versus problem solving**

Radford (1996) distinguishes between two approaches to school algebra: one is generalisation of patterns; the other is problem solving (in the sense of equations arising from word problems). This categorisation is consistent with Nicolas Balacheff's (2001) distinction between algebra as the study of patterns, and algebra as generalised arithmetic. Algebra as the study of patterns is marked by the recognition and description of general rules for describing patterns (Stacey & MacGregor, 2001; Kirshner, 2001). In this approach, letters are viewed as variables, and the study of structures and relationships is an important part (Bloedy-Vinner, 2001). Algebra as generalised arithmetic is about the properties of numbers and operations on numbers (Stacey & MacGregor, 2001; Bloedy-Vinner, 2001, p. 178). In this approach, letters are viewed as specific unknowns (e.g.,  $a + b = b + a$ , for  $a$  and  $b$  arbitrary numbers; the commutative law of addition).

Giuliana Dettori, Rossella Garuti, and Enrica Lemut (2001) observe that a dilemma for students in a problem-solving process is the need for them to be able, on the one hand, to associate meanings with the symbols being used, and, on the other, to manipulate symbols independently of their meaning. In Kirshner's (2001) conceptualisation, to associate meanings with symbols used means to have a referential approach (im-

porting meaning from external sources of reference), and to manipulate symbols independently of their meaning means to have a structural view (building meaning internally from the connections generated within a syntactically constructed system).

The distinction between the two approaches to algebra raises important questions regarding the learning of fundamental concepts of algebra such as the notions of variable and unknown. According to Radford (1996), the goal of generalising spatial or numerical patterns is to find an expression representing the conclusion derived from the observed facts (concrete numbers). Radford claims that the obtained expression is in fact a *formula* which is constructed on the basis, not of the concrete numbers in the sequence, but on the idea of a *general number*. Radford asserts that “general number” appears as precepts to the concept of variable. Hence, he claims that the notion of *letter as variable* is consistent with a generalising approach to algebra, aiming at establishment of *relations between numbers*. The point is constructing formulae where the symbols represent generalised numbers (Radford, 1996).

According to Radford (1996), the goal of algebraic problem solving is not to find a formula, but to find a *number* through an equation. This number is represented in the equation by an unknown (a letter). The notion of *letter as unknown* is therefore consistent with a *problem solving* approach where the point is to solve problems where the symbols represent unknowns (Radford, 1996). He notes that the difference in the situations of generalising patterns and solving equations is not unique at the word level (they are represented by the same algebraic symbols), a fact that can lead us to believe that an unknown is only a variable, and an equation is only a type of formula. Radford, further, claims that this fundamental difference often goes unnoticed, even in text books and school guidelines.

#### *Different logical bases of pattern generalisation and algebraic problem solving*

A goal in generalising spatial and numerical patterns is to obtain a new result. Radford (1996) claims that conceived in this form, generalisation is not a concept, but a procedure allowing for generation of a new result (a conclusion), based on observed facts. He highlights that one of the most significant characteristics of generalisation is its logical nature which makes the conclusion possible. This means that the process of generalisation is closely connected to that of justification and proof. The underlying logic of generalisation can be of various types, depending on the student’s mathematical thinking. Balacheff (1988) distinguishes between *pragmatic* and *conceptual* proofs in school mathematics, and has identified four types of reasoning in pupils’ practice of proof in school mathematics: Naïve empiricism, the crucial experiment, the generic ex-

ample, and the thought experiment. Proofs by naïve empiricism, a crucial experiment and a generic example are pragmatic proofs, which have “recourse to actual actions and showings” (Balacheff, 1988 p. 217). These types emerge in the data analysis reported in later chapters; therefore I will explain them in more detail in the following paragraphs.

Many students think that some examples (even one or two) are sufficient to justify the conclusion, a stance categorised by Balacheff (1988) as *naïve empiricism*. Other students think that the validity of a conclusion is accomplished by testing it with a special member of the sequence, for instance the 100th member, a stance categorised by Balacheff as a *crucial experiment*. A *generic example* involves making explicit the reasons for the truth of an assertion by means of operations on an object that is a representative of the class of elements considered (Balacheff, 1988). The numbers or items in a generic example are placeholders, in which different particulars could occur (Mason & Pimm, 1984). A generic example is an example *of* something; the validity of a hypothesis is argued for by the characteristic properties of this example. Balacheff (1988) states that the *thought experiment* is a conceptual proof which requires that the one who produces the proof distances himself from the action and processes of solving the problem; he must give up the actual object for the class of objects on which relations and operations are to be described. In order for this to happen, “language must become a tool for logical deductions and not just a means of communication” (Balacheff, 1988, p. 217).

Balacheff (1988) emphasises that a proof by naïve empiricism or by a crucial experiment does not establish the truth of an assertion. He uses the word “proof” only because they are recognised as such by their producers. The generic example and the thought experiment are, however, valid proofs (Balacheff, 1988). They involve a fundamental shift in the students’ reasoning underlying these proofs: “It is no longer a matter of ‘showing’ the result is true because ‘it works’; rather it concerns establishing the necessary nature of its truth by giving reasons” (Balacheff, 1988, p. 218).

As expressed above, Radford (1996) states that the logical base underlying generalisation is that of justification of the conclusion. It is a proof process, which moves from empirical knowledge (related to the observed number facts in a sequence) to abstract knowledge that is beyond the empirical scope. It is important, according to Radford, to notice that the logical base of algebraic problem solving is found in its analytical nature, not in a process of justification. When solving an equation it is assumed that the number sought is known, and the number is treated as if it were known, so that its identity can be revealed in the end. In this process unknowns are used as abstract objects that can be manipulated.

Radford (1996) claims that “the generalization way of thinking and the analytic way of thinking that characterises algebraic word problem solving are independent and essentially irreducible, structured forms of algebraic thinking” (p. 111).

In the next section I explain in more detail what pattern generalisation involves when used as an approach to algebra.

### 3.3 Algebra introduced through generalisation of patterns

#### 3.3.1 Abstraction and expression of generality

That algebra and indeed all of mathematics is about generalising patterns is asserted by mathematician and philosopher Whitehead (1947):

The history of the science of algebra is the story of the growth of a technique for representation of finite patterns. . . . Now in algebra, the restriction of thought to particular numbers is avoided. We write  $x + y = y + x$  where  $x$  and  $y$  are any two numbers. Thus the emphasis on pattern as distinct from the special entities involved in the pattern, is increased. Thus, algebra in its initiation involved an immense advance in the study of pattern. . . . Mathematics is the most powerful technique for the understanding of pattern, and for the analysis of the relationships of patterns. (pp. 107-109)

The mathematician Hardy (1940/1992) put it: “A mathematician, like a painter or a poet, is a maker of patterns. If his patterns are more permanent than theirs, it is because they are made with *ideas*” (p. 84). Anna Sfard (1995) defines algebra in terms of generalisation: “I use the term algebra with respect to any kind of mathematical endeavour concerned with generalized computational processes, whatever the tools used to convey this generality” (p. 18). Consequently, Sfard does not require the result of a generalisation process to be expressed by means of algebraic symbols for it to be termed *algebra*. Sfard’s stance is not uncontested; a contrasting stance set out by Carolyn Kieran (1989) is introduced in Section 3.3.2.

John Mason, Alan Graham, David Pimm, and Norman Gowar (1985) identify four roots of algebra: 1) expressing generality; 2) possibilities and constraints (supporting awareness of variable); 3) rearranging and manipulating (seeing why apparently different expressions for the same thing do in fact give the same answers); and, 4) generalised arithmetic (traditional letters in place of numbers to express the rules of arithmetic). I will in the following concentrate on the first root, that of *expressing generality*.

Mason (1996) claims that the heart of teaching mathematics is the awakening of pupils’ sensitivity to the nature of mathematical generalisation and to specialisation. At school, algebra has come to mean “using symbols to express and manipulate generalities in number contexts”

(Mason, 1996, pp. 73-74). However, as Mason notes, every discipline is concerned with expressing generality, with differences only in what the generality is about and the way generalities are justified. Caleb Gattegno (1990, as cited in Mason, 1996, p. 74) puts forward that: “Something is mathematical only when it is shot through with infinity”. Mason (1996) takes this to mean that to be fully mathematical, there has to be a generality present, and claims that “lessons that are not imbued with generalisation and conjecturing are not mathematics lessons, whatever the title claims them to be” (p. 84).

In a process of recognising and expressing generality, the question is how teachers can attract student attention, evoke awareness, and assist them to experience requisite shifts of attention. Mason (1989) builds on Jerome Bruner’s (1964) notions of enactive, iconic, and symbolic representations when he defines the categories of *manipulating*, *getting-a-sense-of*, and *articulating*. They are thought of as different phases in a developing spiral, in which

manipulation (whether of physical, mental, or symbolic objects) provides the basis for getting a sense of patterns, relationships, generalities, and so on; the struggle to bring these to articulation is an on-going one, and as articulation develops, sense-of also changes; as you become articulate, your relationship with the ideas changes; you experience an actual shift in the way you see things, that is, a shift in the form and structure of your attention; what was previously abstract becomes increasingly, confidently manipulable. (Mason, 1996, pp. 81-82)

As Mason observes, others refer to abstraction (seeing a generality through the particular) and concretisation (seeing the particular in the general) in different language, and with different emphasis, for example, “as reification (Sfard, 1991, 1992), as reflective abstraction (Dubinsky & Lewin, 1986), as concept image (Tall & Vinner, 1981), and so on” (Mason, 1996, pp. 65-66).

A scrutiny of established school practices involving algebraic generalisation reveals that students often, when asked to express the general member of a sequence of numbers or shapes (geometric configurations), construct a table of values<sup>43</sup> from which an explicit formula is extracted and checked with one or two examples (Bednarz, Kieran, & Lee, 1996).

---

<sup>43</sup> In the case of a sequence of shapes, the table consists of values arising from the number of building blocks (components) of the shapes.

Mason (1996) suggests that an approach like that in effect obstructs all the richness of the process of generalisation:

Students remain unaware of the generality in a formula they conjecture because, in most mathematical topics, teachers collude with them to keep their attention focused on the technique in particular cases, and not on the technique *qua* technique, together with questions about the domain of the applicability of the technique. (p. 76)

John Mason and Joy Davis (1991) claim that students' readiness to accept a few examples as confirming evidence of the correctness of a conjecture is connected with lack of experience in formulating generalities for themselves. Several investigative approaches that can lead to students' construction of a formula for the general member of the sequence mapped from the shape pattern are put forward by Mason (1996): visualisation; manipulation of a generic element on which the generalisation is based; establishment of a recursive rule that shows how to construct the successive member from preceding ones; and, identification of the structure of the pattern which can lead to an explicit formula.

Lesley Lee (1996) reports on results from a teaching experiment that focussed on very particular generalising activities that involved the use of algebraic symbolism. Six adult students enrolled in an elementary course in algebra were tested and taught using four different generalising activities, based mainly on generalising numerical and spatial patterns (dot patterns). Lee found that the students identified different patterns, and that the question of finding a formula that described the numerical value of the general element of the pattern was a question of sorting out what is an *algebraically useful pattern*.

Lee (1996) found that the generalisation approach to algebra in the teaching experiment immediately threw students into using letters as variables, making even low attaining students participate in what she refers to as an *algebraic culture*. She observes that the infinite series generated by many of the activities have potential to lead students into reflections on infinite processes, limits and the calculus. However, the generalisation approach used by Lee (1996) was not without difficulties. She comments that there were obstacles identified at three levels: at the perception level (seeing the intended pattern); at the verbalisation level (expressing the pattern clearly); and, at the symbolisation level (using  $n$  to represent the position of a member in the sequence and then expressing the member as a function of  $n$ ).

### 3.3.2 Algebraic thinking

#### *Three definitions of algebraic thinking*

Mason (1996) defines algebraic thinking as noticing sameness and difference, making distinctions, repeating and ordering, and classifying and labelling. Through a series of particular examples Mason develops the



point that *expressing generality* is the key process underlying deep understanding of algebra.

Radford's (1996) definition of algebraic thinking is broader than Mason's (1996) definition; it includes generalisation that leads to concepts of variable and function, and the analytic reasoning that is involved in algebraic problem solving. In algebraic problem-solving, unknowns are treated as abstract objects that can be manipulated, in contrast with arithmetic methods where reasoning begins with what is known.

A more recent definition of algebraic thinking is given by Romulo Lins and James J. Kaput (2004). Based on agreement among the members of the Working Group of Early Algebra at the 12th ICMI Study Conference<sup>44</sup>, they define algebraic thinking in terms of two key characteristics: "First, it involves acts of deliberate generalisation and expression of generality. Second, it involves, usually a separate endeavour, reasoning based on the *forms* of syntactically-structured generalisations, including syntactically and semantically guided actions" (Lins & Kaput, 2004, p. 48). The first characteristic is consistent with Mason's (1996) and Radford's (1996) common category of noticing and expressing generality. The second characteristic of Lins and Kaput is about dealing with formalisms in the sense of manipulating symbols. When dealing with formalisms, the attention is on the symbols and syntactical rules for changing their form (manipulating them); however it is possible to act on formalisms semantically, where one's action is guided by what one believes the symbols *stand for* (Kaput, 1995). For instance, when the general member of a sequence is represented by  $x^2 + x$ , it can syntactically be converted into  $x(x + 1)$ . The expression  $x^2 + x$  can semantically be interpreted as the sum of a number and its square (arithmetic interpretation), or as the sum of two areas being a square with side length  $x$  and a rectangle with side lengths  $x$  and 1 (geometric interpretation). The expression  $x(x + 1)$  can semantically be interpreted as the product of two numbers, in which one factor exceeds the other by 1, or  $x(x + 1)$  can be interpreted as the area of a rectangle with side lengths  $x$  and  $x + 1$ .

In addition to dealing with formalisms in the context of generalising patterns, Lins and Kaput's (2004) second characteristic of algebraic

---

<sup>44</sup> The conference, entitled *The Future of the Teaching and Learning of Algebra*, was held at the University of Melbourne, Australia from 9th to 14th December, 2001.

thinking also includes dealing with formalisms in the context of problem solving. This may be exemplified by two different ways of solving the equation  $\frac{x}{4} + 3 = 11$ . One way is syntactically guided, in which the symbols are treated as objective entities in themselves, and the conceptual system of rules applies to the system of symbols, not to what they might represent. In this case, one applies a rule for subtracting 3 from both sides of the equation to get  $\frac{x}{4} = 8$ , and then one multiplies both sides by 4 to get  $x = 32$ . The other approach is semantically guided, where one reasons within the conceptual numerical system represented by the equation. This approach can be seen as an inverting process; if 3 is added to one fourth of a number, one gets 11. Hence, one fourth of the number must be 8, so the number must be 32.

Mason's (1996) definition of algebraic thinking is useful because he explicates what algebraic thinking in the context of pattern generalisation entails. Radford's (1996) definition of algebraic thinking is useful because he includes both pattern generalisation and analytic reasoning involved in algebraic problem solving, and describes how the logical bases underlying these two types of algebraic thinking are different (see Section 3.2). The definition of algebraic thinking given by Lins and Kaput (2004) contributes a third dimension to the act of algebraic thinking, because it includes reasoning based on the *forms* of syntactically-structured generalisations, be it in the context of generalisation or that of algebraic problem solving.

#### *The role of algebraic symbolism in algebraic thinking*

When the term algebra is used, it involves the concepts algebraic thinking and algebraic symbolism. There is however disagreement among scholars about the relationship between the two concepts. According to Rina Zazkis and Peter Liljedahl (2002), some view algebraic symbols as a necessary component of algebraic thinking, while others view them as an outcome of algebraic thinking or as a communicative tool.

Kieran (1989) suggests that seeing the general in the particular is not a sufficient characterisation of algebraic thinking; the generality must be expressed algebraically. She distinguishes between the ability to generalise and the ability to think algebraically, when she makes this claim:

Generalization is neither equivalent to algebraic thinking, nor does it even require algebra. For algebraic thinking to be different from generalization, I propose that a necessary component is the use of algebraic symbolism to reason about and to express that generalization. (Kieran, 1989, p. 165)

Kieran's stance towards algebraic symbolism is in contrast to Sfard's (1995) stance, as presented in Section 3.3.1. Willi Dörfler (1991) suggests that theoretical generalisation needs a certain symbolic description,

but believes that it does not necessarily involve the use of algebraic symbols. According to Dörfler (1991), the symbolic descriptions can be verbal, iconic, geometric or algebraic in nature. I find Kieran's (1989) definition useful because it aims to point out what distinguishes generalisation in a broad sense (a process in all disciplines) from algebraic thinking, where the latter is a *mathematical* activity.

In the next section I present a summary overview of reports from empirical studies in which a pattern-based approach to algebra is used.

### **3.4 Literature summary of reports from empirical studies of students' pattern generalisation**

The summary overview of empirical studies of students' pattern generalisation presented in this chapter will concentrate on three aspects: lack of evidence that the pattern-based approach to algebra is better with respect to student achievement than the traditional "letter-as-specific-unknown" approach; students' difficulties in establishing algebraic rules from patterns and tables; and, important components of a successful pattern-based approach to algebra.

#### *Comparison of the pattern-based approach and the traditional "letter-as-specific-unknown" approach to algebra*

Kaye Stacey and Mollie MacGregor (2001) observe that mathematics curriculum documents from Australia, United Kingdom, and The United States promote the view that algebraic thinking begins to develop in the primary grades through experiences of generality and recognition of general relationships in shape patterns and number sequences. Introducing algebraic letters as pattern generalisers instead of as specific unknown numbers is a clear break with tradition and is derived from the desire to identify early algebra in school with algebraic thinking rather than with manipulation of formalisms based on syntactical rules (Stacey & MacGregor, 2001). Stacey and MacGregor are critical of these recommendations because they find little evidence in published research that might support the change from the traditional "letter-as-specific-unknown" approach to the pattern-based "letter-as-variable" approach. They refer to Küchemann's (1981) study, and suggest that his study may be taken as an argument against a pattern-based approach. Küchemann found that algebra test items which required a letter to be interpreted as a generalised number or variable were found to be harder than most other items where letters could be thought of as representing particular unknown values.

MacGregor and Stacey (1992, 1993) carried out research on approximately 2000 students in Years 7 to 10 (aged 12 to 15). The study involved written tests of whole classes in a variety of schools, and inter-

views with individual students. Some of the schools had used a pattern-based approach to algebra, whereas others had used a traditional approach. Analysis of students' responses to the test items showed that students taught with a pattern-based approach were not better at the algebra items in the test, even though these items were close to the types they would have practiced in the classroom. Stacey and MacGregor (2001), in their discussion of these findings, wonder how well the approaches to algebra really were being taught. Their analysis of the way the pattern-based approach is presented, at least in some textbooks, illustrates that "it is reduced to a routine, and is a far way from the rich lessons described by Pegg and Redden (1990)" (Stacey & MacGregor, 2001, p. 152).

*Students' difficulties in establishing algebraic rules from patterns and tables*

Several studies have documented students' difficulties in establishing algebraic rules from patterns and tables. In the following paragraphs I present a selection of these studies, which particularly illuminate my inquiry.

Stacey (1989) reports responses to linear generalising problems of 140 students aged between 9 and 13. Generalisation of the given problems was of the type  $f(x) = ax + b$  with  $b \neq 0$ .<sup>45</sup> It turned out that mainly two ideas were used. Stacey refers to these as the *difference method* and the *whole-object method*. The difference method involves multiplying the common difference between members of a sequence by the rank of a member to calculate its numerical value. The whole-object method involves taking a multiple of the numerical value of a member of a sequence to calculate the numerical value of a member with a higher rank; that is, implicitly assuming that  $f(mn) = mf(n)$ . The two methods will be applicable only when the linear problems are direct proportionalities.

---

<sup>45</sup> The linear generalising problems to which Stacey's students were exposed were questions which required students to observe and use a linear pattern of the form  $f(n) = an + b$  with  $b \neq 0$ . As Stacey (1989) notes, there is some confusion about the term *linear* in this context. Although an equation  $y = ax + b$  is always called a linear equation, the function  $f(x) = ax + b$  is an *affine* function (i.e., a linear function plus a translation). It is not a linear function in the vector space sense because  $f(x_1 + x_2) \neq f(x_1) + f(x_2)$  and  $f(mx) \neq mf(x)$ . However, the notion "linear" is used by Stacey instead of the notion "affine" to avoid what she conceives of as excessive pedantry.

Because the problems used by Stacey in her study were not direct proportionalities ( $b \neq 0$ ), the difference method and the whole-object method were invalid. The erroneous generalisations were not discovered by the students because they failed to check the validity of the rules they produced.

Another finding from Stacey's (1989) study was that students showed a tendency to focus on recurrence relations in one variable rather than on functional relationships between two variables. As an example, on the "Ladders task" (Figure 3.1), the difference method produced the most common pair of wrong answers,  $M(20) = 60$  and  $M(1000) = 3000$ , where  $M(r)$  denotes the number of matches needed for a ladder with  $r$  rungs. This answer was often accompanied by an explanation such as "you add on three matches for every rung" (Stacey, 1989, p. 152). An algebraic expression that would represent the relationship between the two variables is  $M(r) = 3r + 2$ .

**LADDERS**

With 8 matches, I can make a ladder with 2 rungs like this

With 11 matches, I can make this ladder with 3 rungs.

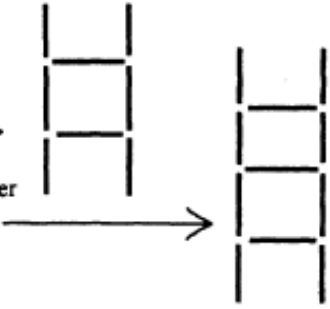

How many matches are needed to make the same sort of ladder with 4 rungs?  
 How many matches are needed to make a ladder with 5 rungs?  
 I know that it takes 335 matches to make a ladder with 111 rungs. How many matches would be needed to make a ladder with 112 rungs?  
 How many matches would you need to make a ladder with 20 rungs?  
 How many matches are needed for a ladder with 1000 rungs?

Figure 3.1. The Ladders task (reproduced with permission, from Stacey, 1989, p. 148)

The same conclusion about students' tendency to focus on recurrence relations was reached by MacGregor and Stacey (1995). They tested approximately 1200 students in Years 7 to 10 in ten schools on recognising, using, and describing rules relating two variables; fourteen students were interviewed.

MacGregor and Stacey (1995) found that the students had difficulties in perceiving functional relationships and expressing them in words and as equations. The students' tendency to find recurrence relations in patterns and tables were in most cases counter-productive to identification

of a relationship between two variables. Hence, MacGregor and Stacey (1995) recommend teachers to use examples where it is not possible to find differences between consecutive members of a sequence (that is, to use sequences in which the input variables do not increase in equal steps).

Anthony Orton and Jean Orton (1996) conducted a study in which 1040 students from Years 6, 7 and 8 (ages 10 to 13) completed a written test on different pattern questions, and 30 of these students were interviewed about their written responses. Five different types of sequences were used in Orton and Orton's study: strings; cycles; tables; linear; and, quadratic.<sup>46</sup> Responses on these five types of sequences enabled comparisons to be made in terms of the ability to complete a generalisation (i.e., to find a formula for the general member of the actual sequence) or continue number patterns. Correlations between the different types were found to be high (Orton & Orton, 1996). In relation to relative difficulty, Orton and Orton claim that students are more successful with linear patterns than with quadratic. Further, they found that students have a clear tendency to use *differencing* methods<sup>47</sup> and identify a recursive pattern which is not easily transformed into an explicit algebraic formula. This result is consistent with Stacey's (1989) finding referred to above.

John K. Lannin, David D. Barker, and Brian E. Townsend (2006) explored students' use of recursive and explicit relationships by examining the reasoning of 25 sixth-grade students, including a focus on four target

---

<sup>46</sup> The term "string" refers to linear patterns based on simple number sequences (included to provide some simple tasks in the beginning of the test), whereas "linear" refers to the same kinds of sequences but presented within tasks where there is an obvious functional relationship (Orton & Orton, 1996). Tabular number patterns were of two types; "cycles", in which the data contained a cyclic property, and "tables", where no cyclic property was present. The "quadratic" patterns in Orton and Orton (1996) were mapped from square numbers and triangular numbers.

<sup>47</sup> The method referred to as the *differencing method* involves that students recognise that the first differences in linear sequences are constant, that the second difference in quadratic sequences are constant, and so forth. Orton and Orton (1999) observe that students' finding these differences is no guarantee that they find the formula for the general member of the sequences. Finding the first differences, though, may be helpful with respect to figuring out the next member of the sequence (also for non-linear sequences). For example, in the sequence of square numbers, the first differences are given by the sequence of odd numbers (hence, it is easy to conjecture the next first difference). However, finding more members in a sequence is usually only the first step towards algebraic generalisation.

students, as they approached three generalisation tasks<sup>48</sup> while using computer spreadsheets as an instructional tool. Their results demonstrate the difficulty experienced by the students when moving from successful recursive formulae towards explicit formulae. Lannin et al. (2006) observe that one factor that appeared to be an obstacle to students' ability to connect recursive and explicit formulae was their limited understanding of the meaning of mathematical operations and of connections between mathematical operations, such as addition and multiplication. According to Lannin et al., provoking students to find explicit formulae may lead to the use of "guess-and-check" strategies that involve superficial pattern spotting. They notice that students' employment of guess-and-check strategies resulted in students remaining unaware of the generality in a formula they conjecture; the target students focused on particular instances rather than general relationships to develop an explicit formula.

The foregoing discussion of students' difficulties in establishing algebraic rules from patterns and tables can be summarised in three points. First, there are difficulties caused by students' use of invalid or unsuccessful methods to identify explicit formulae. These methods can be categorised into two main types: one type involves using differences (two different methods; the *difference method* and *differencing*); the other type involves taking a multiple of a member of a sequence to calculate a member with a higher rank (the *whole-object method*). Second, there are difficulties caused by students' tendency to focus on recurrence relations because focus on an indirect relationship (between consecutive members of a sequence) is in many cases counter-productive to identification of an explicit relationship (between the rank of a member and the member itself). Third, one factor that appears to be an obstacle in transforming recurrence relations into explicit relationships is students' limited understanding of the meaning of mathematical operations and connections between them.

*Important components of a successful pattern-based approach to algebra*

Results from Ted Redden's (1996) study demonstrate a significant association between natural language descriptions and symbolic notation

---

<sup>48</sup> One task was a shape pattern (referred to as *Theatre Seat problem*), the others were text problems (referred to as *Pizza Sharing problem* and *Phone Cost problem*).

used by students. On the basis of investigation of how 1435 children aged 10 to 13 responded on requests to generalise shape patterns, he found that natural language descriptions exclusively in terms of functional relationships appear to lead to students' successful use of algebraic notation. This finding indicates that students need to be able to explain a pattern in terms of relating the independent variable to the dependent variable, which means relating the position of a member in a sequence<sup>49</sup> to the member itself.

Whereas Redden's (1996) study demonstrates significant correlation between natural language description of functional relationships and students' ability to use symbolic notation, Elisabeth A. Warren (2000) demonstrates significant correlation between students' ability to reason visually (identify, analyse, and describe patterns) and successful algebraic generalisations from shape patterns and tables of values. Warren's finding is based on responses on two written tests administered to 379 students; aged between 12 and 15 years (16 of whom were interviewed in groups of four students).

Elisabeth A. Warren, Tom J. Cooper, and Janeen T. Lamb (2006) examined the development of students' functional thinking during a teaching experiment that was conducted in two classrooms with a total of 45 Year 4 students (average age nine and a half years). They found that the fact that input values in a table did not increase in equal steps assisted students to search for relationship between two data sets instead of focusing on variation within one. The randomness of the input values encouraged students to think relationally instead of sequentially, a finding which is consistent with MacGregor and Stacey's (1995) recommendation referred to above.

Against the background of the research reported in Lannin et al. (2006) presented above, Lannin et al. recommend that students be encouraged to connect recursive and explicit formulae. Further, they emphasise the importance of building students' understanding of the meaning of connections between mathematical operations, such as addition and multiplication. Furthermore, they recommend that tasks which involve generalisation of shape patterns be designed so as to promote students to remain connected to the iconic (figural) representation and avoid

---

<sup>49</sup> The members referred to here are members of the number sequence mapped from the shape pattern (the numerical values of the corresponding shapes).



the desire to apply a guess-and-check strategy. Lannin et al.'s opinion about remaining connected to the original context is consistent with David Hewitt's (1994) experiences. Hewitt describes five lessons in which students were encouraged to find connections, to make and test conjectures, to establish generalisations, and to express these in algebraic form. Even if the mathematical problems in the lessons he observed were of different types (topology, shape pattern, geometry, number theory, and probability) the activity in all lessons ended up with tables of numbers and the students trying to find patterns in the numbers. He claims that spotting patterns in number sequences this way becomes an activity in its own right and not a means to gain insights into the original mathematical situation (Hewitt, 1994). He assumes that "more might be learnt about the original mathematics if one particular situation were looked at in depth, rather than rushing through several in order to collect results" (Hewitt, 1994, p. 49).

The foregoing discussion of important features for a successful pattern-based approach to algebra can be summarised in five points. First, students' mastery of expressing functional relationships in natural language is correlated with the ability to use symbolic notation. Second, students' ability to reason visually (identify, analyse, and describe patterns) is correlated with successful algebraic generalisations from shape patterns and tables of values. Third, teacher's use of tables of values in which the input variables do not increase in equal steps is important to encourage students' identification of functional relationships; this in order to avoid that students find differences between consecutive members and develop a recurrence relation. Fourth, students' tendency to find recurrence relations should be acknowledged and students should be encouraged to find connections between recursive and explicit formulae so as to stimulate sense-making of explicit formulae. Fifth, tasks should be designed so as to promote students to remain connected to the geometrical configurations and avoid the desire to apply a "guess-and-check" strategy.

Blanton and Kaput (2004) have demonstrated that children are capable of thinking functionally at an early age. In the next section I present a strategy developed by Kaput and Blanton termed the "algebraifying" strategy, for helping teachers to promote students' algebraic thinking (Kaput & Blanton, 2001a, 2003). Results from a case study in which a teacher has participated in a professional development project will be presented, together with its impact on students' achievement.

### **3.5 Promoting students' algebraic thinking**

In the following paragraphs I present a strategy developed by Kaput and Blanton (2001a, 2003) for helping elementary teachers to learn to identi-

fy and create opportunities for algebraic thinking as part of their normal instruction and to use their own resources such as textbooks and complementary materials. Developing children's capacity for algebraic thinking is an important goal also in the Norwegian mathematics curriculum from elementary through secondary education (Directorate for Education and Training, 2006). Kaput and Blanton have developed an explicit "algebrafication" strategy, which involves classroom-grounded teacher development in three dimensions (Kaput & Blanton, 2001a):

*"Algebrafying instructional material"*. This involves building opportunities of algebraic thinking, especially generalisation and formalisation opportunities, from available instructional materials, including the algebrafication of existing arithmetic problems by transforming them from one-numerical-answer arithmetic problems to opportunities for pattern building, conjecturing, generalising, and justifying mathematical facts and relationships;

*Building of teachers' "algebra eyes and ears"* so they can identify opportunities for generalisation and systematic expression of that generality (including written expression) and then exploit these as they occur across mathematical topics;

*Creating a classroom culture and practices that promote algebraic thinking*. This involves encouraging and supporting active student generalisation and formalisation within the context of purposeful conjecture and argument, so that opportunities of algebraic thinking occur frequently and are viable when they do occur.

Results from a case study which examined the classroom practice of one third-grade teacher as she participated in a long-term professional development project led by Blanton and Kaput are reported in Blanton and Kaput (2005). They analysed one year of the teacher's classroom instruction to determine the robustness with which she integrated algebraic thinking into the regular course of daily instruction and its subsequent impact on students' ability to reason algebraically. The diversity of types of algebraic thinking, their frequency and form of integration, and techniques of instructional practice that supported students' algebraic thinking was taken as a measure of the robustness of the teacher's capacity to build algebraic thinking (Blanton & Kaput, 2005). Results from this study indicate that the teacher was able to integrate algebraic think-

ing into instruction in planned and spontaneous ways that led to positive shifts in students' algebraic thinking skills.

Impact on students' achievement of the developmental project led by Blanton and Kaput (referred to above) is reported in Kaput and Blanton (2001b). The teacher who participated in the professional development project had a class of fourteen 3rd grade students, a class with low socioeconomic status (SES) by standard measures.<sup>50</sup> Kaput and Blanton administered a set of fourteen test items selected from a 4th grade state-wide mandatory exam to the experimental class and to a second 3rd grade control class with comparable SES from the same school (Kaput & Blanton, 2001b). Analysis of students' responses to the test items, in both individual and partner settings, offers evidence to support the strategy adopted by Blanton and Kaput (2005) with elementary teachers as a means to build classrooms that prioritise students' development of competencies to formulate generalisations, and express those generalisations in increasingly formal ways.

An item analysis comparing the results of Kaput and Blanton's experimental class with the results of the control group (whose teacher did not participate in the development project) shows that the experimental class outperformed the control group on 11 of the 14 test items (Kaput & Blanton, 2001b). Moreover, the experimental class performed significantly better than the control group on 4 of these 11 items (Kaput & Blanton, 2001b). Of the 14 items on the assessment, Kaput and Blanton identified seven as being deeply algebraic in nature, requiring students to continue sequences of shapes and numbers, understand whole number properties (e.g., commutativity), and identify unknown quantities in number sentences.

Kaput and Blanton (2001b) find it significant that the experimental group outperformed the control class on 6 out of 7 of these items. They consider the test results, taken together, to provide strong evidence in favour of the innovation: "These results indicate that the experimental 3rd grade class performed approximately as well as the 4th graders state-wide, and significantly better than the district 4th graders" (Kaput & Blanton, 2001b, p. 102).

---

<sup>50</sup> The socioeconomic status of this class and that of the school was lower than average for the district, with 75 % on free and 15 % on reduced lunch, 65 % with parents for whom English was a second language, and 25 % with no parent living at home (Blanton & Kaput, 2005, p. 416).

In the next section I present reflections made by researchers on the teacher's role in students' algebra learning.

### **3.6 The teacher's role in students' algebra learning**

The meanings that students construct for and in algebra are related to the types of problems which are prioritised in the mathematics classroom (Lins, Rojano, Bell, & Sutherland, 2001). It is therefore important to be aware of the kind of meaning that is desired for students to construct. However, as Lins et al. (2001) observe, presenting algebra problems to students is not enough for students to learn algebra:

The traditional approach of presenting students with so-called algebra problems may have worked for some students when the teacher more or less imposed an algebraic solving approach. The current trend however is to encourage students to solve problems for themselves, without imposing [an algebraic] problem solving approach. (p. 10)

There may be a problem with this independence, because students are likely to solve these problems in many non-algebraic ways. Lins et al. (2001) doubt that algebraic approaches can develop in a "seamless way" from students' non-algebraic approaches (p. 11).

Falk Seeger (1989), drawing on Davydov's theory of generalisation (Davydov, 1972/1990), claims that the teacher plays an important role in cultivating algebraic thinking in students (see also, Davydov, 1988). Seeger observes that the use of manipulatives and representations requires abstractions to be developed, and asserts that if abstractions are to be meaningful for students, it is not adequate to only view them as cases where students have to perform concrete activities: "The power of 'meaning' and 'abstraction' can only flourish in a certain climate. This climate is produced by teacher-student-interaction" (Seeger, 1989, pp. 17-18).

Seeger's (1989) assertion about the importance of the teacher's role in promoting algebraic thinking in students is supported by Sonia Ursini's (2001) results from investigation of the feasibility of helping 12-13 year old students to develop a pre-algebraic experience through Logo. She claims that in order for students to develop understanding of variable as a general number, "substantial teacher's support and guidance are required" (p. 213). Balacheff (2001), further, compares algebra learning with learning mathematical proof and asserts that

there is no possible entrance to the world of algebra without a strong push and guidance from the teacher because there is no natural passage from the problématique accessible from the child's world to the mathematical problématique. . . . [A]lgebra may be the first theoretical experience mathematics teaching offers to the student. (Balacheff, 2001, pp. 259-260)

This statement emphasises the importance of the teacher and warns against believing that "good" problems alone will provoke algebra learn-

ing. The point that there is no natural passage from the students' world to the world of algebra is also made by Lins (2001) who uses a theoretical model of Semantic Fields in his argument that there is no transition from "concrete to abstract" with respect to algebra learning. He discusses the teacher's role in a classroom approach where the focus is on algebraic thinking as a way of producing meaning for algebraic notation, rather than on an "intrinsic meaning" of algebraic notation. Relevant in this respect is experiences from Vasilij V. Davydov's (1962) experimental programme used to teach scientific knowledge in mathematics in the first and second grade. Davydov's (1962) results show that it was possible to teach mathematics to children in elementary school as a science of quantitative relationships (in which the concept of number is learned as a relationship between a magnitude and a unit of measure) and dependencies of magnitudes in algebraic form.

According to Balacheff (2001), it is the *didactical contract* (Brousseau, 1997) that can regulate the student-teacher interaction and qualify what counts as an adequate algebraic solution to a mathematical problem. In other words, the teacher plays a central role in encouraging students to locate themselves in the relevant paradigm and "play the game" of algebra, especially when it would be possible and even more economical for them not to do so (see also, Kieran, 2004).

In the next section I argue that the research presented in this chapter is relevant for my research on student teachers' algebraic generalisation of shape patterns. Furthermore, I will show how the research presented in this chapter informs my research inquiry.

### **3.7 Relevance of research on students' generalisation of patterns for this research inquiry**

My research inquiry reported in this dissertation is about student teachers' algebraic generalising of shape patterns. The research results summarised in Section 3.4 and Section 3.5 are, however, about children's pattern generalisation. Hence, there is a question of the relevance of these studies for my study of student teachers. In the following I provide support for the stance that being an adult does not lead to an elimination of the kinds of difficulties that children encounter. The point is to establish that outcomes from studies of children's generalisation of patterns are relevant for research on adults' generalisation of patterns.

Jean Orton, Anthony Orton, and Tom Roper (1999) refer to written examination results of adults who wished to train as teachers and therefore needed to provide evidence of satisfactory attainment in mathematics.<sup>51</sup> Three cohorts, one per year, with a total of 123 adults (considered academically very able candidates) were involved in the study reported by Orton et al. (1999). Each year one question in the examination involved generalising from a pattern of dots. The candidates were asked to predict the number of dots for the fifth, tenth, fiftieth and the  $n$ -th member of the sequence; in all cases the formula was quadratic (Orton et al., 1999). Orton and colleagues found that these mature adults, like many children, are likely to first approach a formula by differences. Furthermore, they found that these adults are able to handle the recursive pattern (based on the differences) very competently, but then have great difficulty in leaving this approach and seeking a better approach which will lead them more successfully towards an explicit formula. According to Orton et al. (1999), this obstacle, noted so frequently with children, is just as evident with adults.

Lee's (1996) study of six adult students, which was presented in Section 3.3.1, reports on obstacles in students' generalisation of patterns at three levels: seeing the intended pattern; expressing the pattern clearly; and, finding a functional relationship between the position of a member in a sequence and the member itself. Lee's (1996) results of adults' difficulties are similar to the results of children obtained by Redden (1996), as presented in Section 3.4. The findings reported by Orton et al. (1999) and Lee (1996) I take as indications that studies of children's difficulties with pattern generalisation can inform my research on student teachers' generalisation of patterns.

In the research reported in this dissertation, I have studied the relationships between three components: the target knowledge (e.g., arithmetic relations in elements of shape patterns, mathematical statements, recursive and explicit formulae, justification of generality); the mathematical tasks and the teaching approach employed; and, the knowings that emerged in the interaction between the students and their *milieu*. Analyses of these relationships are informed by the theoretical outline and

---

<sup>51</sup> This requirement was independent of age range and subjects they expected to teach (Orton et al., 1999).

summary overviews presented in this chapter. In the following paragraphs I explain how.

Analysis of the observed students' engagement with one of the tasks that involved no prescribed type of formula (recursive or explicit) showed that the students focused on a recurrence relation, whereas the teacher aimed at an explicit formula. It resulted in the production of Topaze effects, analyses of which will be presented in Chapter 6. Students' tendency to focus on recurrence relations is documented through research presented in Section 3.4 (Stacey, 1989; MacGregor & Stacey, 1995; Orton & Orton, 1996). Furthermore, one of the observed groups had a problem with symbolic notation of recursive formulae, a phenomenon reported by Lannin et al. (2006).

Another constraint to students' appropriation of algebraic generality, presented in Chapter 6, is the teacher's use of generic examples without the students' awareness of them. This is a feature noticed by Mason (1996). Lannin et al. (2006) reported on students' difficulties in moving from successful recursive formulae towards explicit formulae. The analysis presented in Chapter 7 shows that this transformation was difficult also for the students whom I observed. One of the constraints related to the generation of a symbolic expression for an explicit formula was identification of how the rank of a member of a sequence is related to the member itself, a phenomenon referred to by Radford (2000) as the *positioning problem*.

Balacheff's (1988) categories of pupils' "proofs" (naïve empiricism, crucial example, and generic example) are used in Chapter 8 in the analysis of a situation of validation where the students' try to justify their conjectured formula. That the teacher plays a very important role in students' algebra learning is asserted by Balacheff (2001), Lins et al. (2001), Seeger (1989), and Ursini (2001). This gives legitimacy to my inquiry into didactical situations intended aimed at students' appropriation of algebraic generality in shape pattern, where the teacher's role is investigated.

In the next chapter I present the research methodology, where I provide a rationale for situating my study within a qualitative, interpretative paradigm and choosing an educational case study as mode of inquiry.





## 4 Methodology

This chapter presents the methodology applied in the research project that enabled me to get insights into the complexity of students' generalisation processes in algebra. My research question is: *What factors constrain students' appropriation of algebraic generality in shape patterns?*

The aim of educational research is “to ensure that the observations, interpretations and judgements of educational practitioners can become more coherent and rational and thereby acquire a greater degree of scientific objectivity” (Carr & Kemmis, 1986, p. 124). Wilfred Carr and Stephen Kemmis (1986) observe that educational research is characterised by its application of “a methodology which enables it to describe how individuals interpret their actions and the situations in which they act” (p. 79). The classroom considered as a social entity reveals aspects of social reality which researchers interpret in different ways. According to Gibson Burrell and Gareth Morgan (1979), there are four different kinds of philosophical assumptions which underpin the nature of social science. These assumptions can be classified under the following branches: ontology; epistemology; nature of human beings; and, methodology (Burrell & Morgan, 1979).

Graham Hitchcock and David Hughes (1995) suggest a temporal relationship between ontology, epistemology, methodology, and methods in social research when they write that “ontological assumptions will give rise to epistemological assumptions which have methodological implications for the choice of particular data collection methods” (p. 21). This is coherent since ontology is about the phenomena with which the research question deals, whereas epistemology is about what can be known about these phenomena, and methodology is about what the researcher can do to expose new knowledge about these phenomena. The ontological and epistemological assumptions underlying my research question are explained in Section 4.1; the research methodology is explained in Section 4.2. In order to make sense of the methods used to expose the evidence required, it is necessary to explain the context of the study first. Hence, the context of the study is presented in Section 4.3, before I return to a discussion of the research methods in Section 4.4.

The outline of the research methods starts with the rationale for choosing an educational case study as style of inquiry (Section 4.4.1). Next follow accounts of the selection of site and research participants (Section 4.4.2), of data sources and instruments used to collect data (Section 4.4.3), and of my own role during data collection (Section 4.4.4). Further, the unit of analysis is explained (Section 4.4.5) and the methods used to analyse the data are accounted for (Section 4.4.6). The chapter closes with a discussion of ethical issues (Section 4.4.7).

## 4.1 Ontological and epistemological assumptions

### 4.1.1 Ontology of the social reality studied

Louis Cohen, Lawrence Manion, and Keith Morrison (2007) claim that ontological assumptions are concerned with the *essence* of the phenomena being investigated. In social science, ontological assumptions have to do with the relationship between the social reality and the individual and examine if the one is dependent or independent of the other (Cohen et al., 2007). In my study, the social reality being investigated is the classroom, or more specifically, the teaching-learning situation (referred to as a didactical situation) aiming at the students' appropriation of algebraic generality in shape patterns.

The aim of the research reported in this dissertation is to gain insights into factors that constrain students' algebraic generalisation of shape patterns. I assume that these factors can be discerned in the didactical situation; in the relationships between the teacher, the students, and the mathematics. Figure 4.1 is a model of these three "instances", where the mathematics is part of the milieu (which is a subset of the students' environment with only those features that are relevant with respect to the target mathematical knowledge).

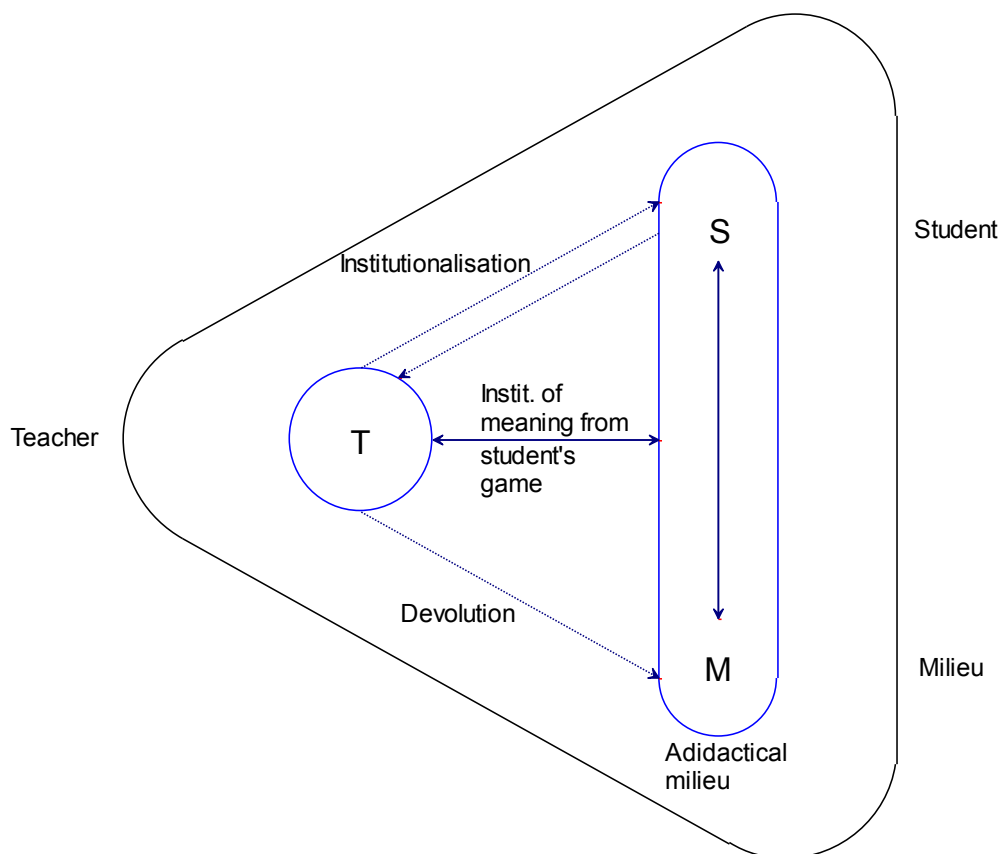

Figure 4.1. Model of the didactical situation illustrating the relationships between the teacher, the student, and the milieu (adapted from Brousseau, 1997, p. 56)

Figure 4.2 illustrates my interpretation of the indirect relationship between the target mathematical knowledge and the student: The dotted line illustrates that there is no direct relationship between the mathematics and the student.

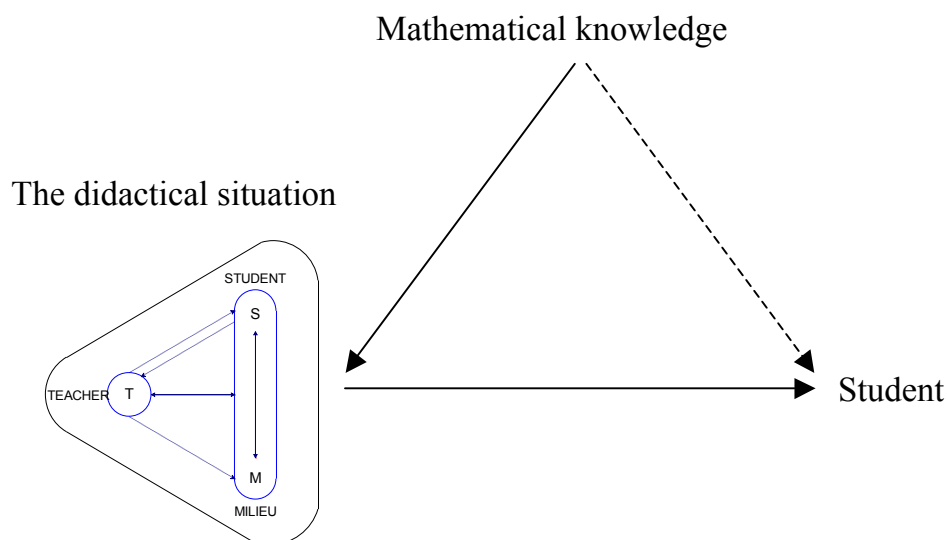

Figure 4.2. Model of the indirect relationship between the target mathematical knowledge and the student – mediated through the didactical situation (presented in Figure 4.1)

The mathematics is mediated to the student through a didactical situation, where the meanings developed by the student in the didactical situation are institutionalised by the teacher to gain the status of cultural, reusable (for the student) mathematical knowledge. Factors that constrain students’ algebraic generalisation processes have, in my analyses, been conceptualised as constraints in the milieu, and as reciprocal obligations between the students and the teacher. The existence of reciprocal obligations has been identified in terms of didactical phenomena which exist because they play a certain rôle in the didactical relationship between the student and the teacher (see Section 2.3).

What I have explained above concerns my assumption about the relationship between the didactical situation in mathematics and the individual. The essence of this assumption is that the didactical situation is dependent on the individuals, where the individuals are the teacher who has designed the situation (with a milieu) and the student who engages in the situation. The mathematics influences the didactical situation via the individual: Via the teacher it is in the form of an *a priori* analysis of the mathematics (no matter how informal that analysis might be) and the mathematics potential that the teacher “sees” in the didactical situation. Via the student it is in the form of prior mathematical knowledge; that is,

how capable the student is to use prior knowledge to engage in the didactical situation devolved to him by the teacher.

In my analysis of the didactical situation I take an *epistemological* approach rather than a psychological approach. That is, I analyse the didactical situation in terms of the triadic didactic relationship between the teacher, the students, and the target mathematical knowledge (which is part of the milieu). This means that my focus is on the students' *possibilities* to appropriate the target knowledge (an epistemological issue) rather than their actual learning (a psychological issue). The epistemological focus is consistent with Vygotskian theory in the way that my research findings provide information about the nature of instruction of scientific concepts related to algebraic generalisation of shape patterns. In Section 9.2 I will discuss the complexity of developing the scientific concept of "mathematical statement".

From what I have explained above, I consider the didactical situation in mathematics as a social entity which is realised through its social participants; the teacher and the students actively construct the didactical situation with its potentialities and constraints. This is an assumption about human nature which is in agreement with *voluntarism*, the philosophical position that asserts that human beings act intentionally and make meanings in and through their activities (Burrell & Morgan, 1979).

The ontological assumptions about the studied reality expressed above are consistent with what Alan Bryman (2001) characterises as a *constructionist* ontology of social phenomena. It is opposed to *objectivism*, the ontological position that asserts that social phenomena and their meanings exist independent of social actors (Bryman, 2001).<sup>52</sup>

In the next section I explain what can be known about the social phenomena I have studied.

#### **4.1.2 Epistemology of the social reality studied**

Torsten Husén (1988) notices that the twentieth century has seen the conflict between two main paradigms employed in educational research. He describes the nature of the two paradigms:

The one is modelled on the natural sciences with an emphasis on empirical quantifiable observations which lend themselves to analyses by means of mathematical tools. The task of research [in this paradigm] is to establish causal

---

<sup>52</sup> Cohen et al. (2007) use the concepts of *nominalism* and *realism*, respectively, to refer to these ontological positions.

relationships, to explain (Erklären). The other paradigm is derived from the humanities with an emphasis on holistic and qualitative information and to interpretive approaches (Verstehen). (Husén, 1988, p. 17)

According to Cohen et al. (2007) the paradigm modelled on the natural sciences is based on an objectivist approach to social science, in which the epistemological position is that of positivism. The paradigm derived from the humanities is based on a subjectivist approach to social science, in which a non-positivist epistemology prevails (Cohen et al., 2007). Two generic terms used to describe these two perspectives, particularly as they refer to social psychology and sociology, are the “normative paradigm” and the “interpretive paradigm” (Cohen et al., 2007).<sup>53</sup>

Whereas ontology of the social reality is about the existence of social phenomena, epistemology of the social reality is about what can be known about the social phenomena studied. As accounted for in the previous section, my aim with the research reported here is to get insights into factors which constrain students’ establishment of algebraic generality in shape patterns. These factors are not observable *per se*; that is, they do not exist as substantial phenomena. I have gained knowledge about them in terms of *interpretations* of relationships between the teacher, the students, and the target mathematical knowledge in terms of the students’ opportunities to appropriate the target knowledge. The gained knowledge comprises analytical statements about the impact of the milieu and didactical phenomena originating from the reciprocal obligations between the teacher and the students in the didactical situation. My aim has been to *understand* what factors have constrained students’ opportunities to appropriate algebraic generality in shape patterns in the actual *context*; it has not been to establish general laws of relationships that constrain algebraic generalisation processes.

Richard Pring (2000) claims that the particular philosophical position that asserts that the research gets at the world as it really is, applies to the physical world, but not to the non-physical world of personal and social meaning. I interpret Pring’s claim to mean that the non-physical world of personal and social meaning (of which a didactical situation is an example) is understood in terms of interpretations of the phenomena studied. Because the phenomena studied (the relationships between the teacher,

---

<sup>53</sup> Other researchers refer to the two perspectives in other terms: for example, Lincoln and Guba (1985) use the terms “positivist paradigm” and “naturalistic paradigm”; Bryman (2001) uses the terms “quantitative research strategy” and “qualitative research strategy”.

the students, and the target knowledge) is understood through my interpretations, what can be known about the reality studied is dependent on me as a researcher.

In the context of the above, epistemological assumptions that underpinned my research were that the knowledge developed would be subjective and contextualised. The underlying epistemological position is the one Husén (1988) refers to as deriving from the humanities. It is consistent with what Bryman (2001) refers to as *interpretivism*, a contrasting epistemology to positivism. He explains that interpretivism “is predicated upon the view that a strategy is required that respects the differences between people and the objects of the natural sciences and therefore requires the social scientist to grasp the subjective meaning of social action” (Bryman, 2001, p. 13).

In the next section I explain what I have done to expose new knowledge about the social phenomena studied.

## 4.2 An idiographic research methodology

In order to get insights into factors that constrain students’ appropriation of algebraic formulae and mathematical statements as representations of generality in shape patterns, it is necessary to study the students’ sense-making in their regular setting (the didactical situation). I have attempted to interpret the observed generalisation processes in terms of the meanings that the students and the teacher brought to the didactical situation. This follows from the ontological stance adopted (explained in Section 4.1.1); I assume that the didactical situation is dependent on the individual. It is also coherent with the epistemological stance adopted (explained in Section 4.2.1); I assume that knowledge of factors that constrain algebraic generality exists in terms of interpretations of relationships between interacting instances in the didactical situation (see Figure 4.1 in Section 4.1.1).

The constructionist ontology and interpretive epistemology of the social reality under study, together with the voluntaristic assumption about human nature, calls for an *idiographic methodology* (Cohen et al., 2007). The employed methodology is idiographic in the sense that the study attempts to explain and understand what is unique and particular to the observed didactical situations, rather than what is general and universal. I understand my unit of analysis (the didactical situation) as one focusing on *mediated action*, which Wertsch (1998) argues is the unit of analysis in sociocultural studies. When I study the didactical situation, I study individuals (the students and the teacher) operating with mediational means (e.g., mathematical tasks, language, signs, algebraic expressions, diagrams, geometrical configurations). This approach is consistent with sociocultural research, as introduced in Section 2.6, where it was stated

that the goal is to “explicate the relationships between human action, on the one hand, and the cultural, institutional, and historical situations in which this action occurs, on the other” (Wertsch et al., 1995, p. 11). As explained in Section 4.1.1, I understand the didactical situation as mediating between the student and the mathematical knowledge (see Figure 4.2).

The idea is that achieving a comprehensive and subtle understanding of just a few participants’ engagement in didactical situations will lead to more general understanding of other students and teachers. The aim is to understand a phenomenon (constraints to students’ appropriation of algebraic generality in shape patterns) in its context. The employed research methodology resonates with what Norman K. Denzin and Yvonna S. Lincoln’s (2005) define as qualitative research:

Qualitative research is a situated activity that locates the observer in the world. It consists of a set of interpretive, material practices that make the world visible. These practices transform the world. They turn the world into a series of representations, including field notes, interviews, conversations, photographs, recordings, and memos to the self. At this level, qualitative research involves an interpretive naturalistic approach to the world. This means that qualitative researchers study things in their natural settings, attempting to make sense of, or to interpret, phenomena in terms of the meanings people bring to them. (Denzin & Lincoln, 2005, p. 3)

In the research reported in this dissertation I study students’ algebraic generalisation processes in their natural setting, in the classroom where two mathematics teachers have interacted with them. A presentation of choice of and rationale for methods adopted follows in Section 4.4. However, to complete this discussion of the philosophical foundation of the study I will conclude this section as if the choice and rationale were already presented.

The students’ collaborative engagement with mathematical tasks has been observed and video recorded and then translated into a series of texts in the form of transcripts which also include accounts of what the students have written during the lessons. These transcripts, together with written accounts of conversations with the teachers, have been analysed from the perspective of my epistemological and didactical analyses of the mathematics potential in the tasks. The transcripts from the students’ engagement with the tasks were thereafter coded in a process of a conceptual interpretation using Brousseau’s theory of didactical situations in mathematics (Brousseau, 1997). Hence, what I have done to expose new knowledge of the studied phenomenon (the didactical situation aiming at the students’ appropriation of algebraic generality in shape patterns) is to interpret the students’ opportunities to learn the target knowledge (rather than their actual learning) from the perspective of my epistemological and didactical analyses of the mathematics potential in the tasks. In this

way I, as a researcher, have been an instrument in the analytical process by the assumptions and theories I have brought to the research field. These features are consistent with the definition of qualitative research as given by Denzin and Lincoln (2005) in the above quotation.

In order to make sense of the methods used to expose the evidence required, it is necessary to explain the context of the study first. Therefore, in the next section I outline this context and return to a discussion of the methodology in Section 4.4.

### **4.3 The context of the study**

In this section I present the teacher education programme on which the students who participated in the research reported here were enrolled. Further, I present the mathematics course in which I collected data in terms of observations of small-group lessons at the university college where the study was conducted. Then I present the students and teachers who were participants in the study, and explain briefly the organisation of the mentioned mathematics course.

#### **4.3.1 The teacher education programme**

The research reported in this dissertation has been conducted within a four-year undergraduate teacher education programme for primary and lower secondary education at a university college in Norway. The students who participated in the research were enrolled on a programme referred to as *Teacher education with emphasis on mathematics and science subjects* (Ministry of Education and Research, 2003). This is a teacher education programme that is distinct from the regular programme with respect to compulsory study units in the last two years.<sup>54</sup> Whereas the regular programme has 120 optional study units during the last two academic years,<sup>55</sup> the programme with emphasis on mathematics and

---

<sup>54</sup> With effect from the academic year 2010-2011, general teacher education in Norway is revised. This involves that there are two parallel programmes geared to the different levels of schooling; one is preparing teachers for Year 1 through 7, the other for Year 5 through 10. The revisions are also reflected in the programme *Teacher education with emphasis on mathematics and science subjects*. Despite the fact that the teacher education programme(s) referred to in this dissertation is no longer in force, I use *present tense* when I refer to it because it *is* the context of the research I report.

<sup>55</sup> Of 120 optional ECTS credits in the ordinary programme, 60 ECTS credits have to be taken in study units preparing for teaching of school subjects in primary and lower secondary school, whereas the remaining 60 ECTS points have to be relevant for teaching in school. 60 ECTS credits is equivalent to one year full-time study.



science subjects involves a compulsory course in mathematics (30 ECTS credits), and two compulsory courses in science (each amounts to 30 ECTS credits) during the last two years.<sup>56</sup> The structure of the programme on which the participating students were enrolled, is shown in Figure 4.3. Didactics of subject matter and practice field experiences are integrated in all study units in the programme.

4.	Mathematics 2      30 ECTS credits Natural Science 2    30 ECTS credits Natural Science 1    30 ECTS credits			
3.	Optional Subject    30 ECTS credits (chosen from subjects taught in primary and lower secondary school)			
2.	Basic RWM* 10 ECTS credits			
1.	Mathematics 1 30 ECTS credits	Norwegian 30 ECTS credits	<div style="border: 1px solid black; padding: 5px; display: inline-block;">           Religious and            Ethical Educa-            tion            20 ECTS credits         </div>	Education 30 ECTS credits

Figure 4.3. Structure of the programme *Teacher education with emphasis on mathematics and science subjects*, in force for students enrolled 2003 (\*RWM is an acronym for Reading, Writing and Mathematics)

The framework for the first two years of the teacher education programme is described in Ministry of Education and Research (2003). The programme involves 20-22 weeks compulsory field practice in schools during the four years the programme spans (Ministry of Education and Research, 2003). Field practice means school-based learning, and involves experiences with teaching in primary or lower secondary school.

<sup>56</sup> Students who are enrolled on the programme with emphasis on mathematics and science subjects can be placed into two categories: One category comprises students who are particularly interested in teaching mathematics and science subjects. The other category comprises students who have lower grades from upper secondary school than those enrolled on the regular programme. Information about the strengths of the students who participated in my research (with respect to mathematics) is provided in Section 4.3.3 (see Tables 4.1 and 4.2).

The field practice is supervised by mentors who are classroom teachers in the respective classes.<sup>57</sup>

### 4.3.2 The mathematics course

Mathematics 1 is a compulsory 30 ECTS credits study unit taught in the first three semesters of the teacher education programme. The main data source in the research reported here consists of observations of small-group lessons from this mathematics course. According to the national framework for teacher education for primary and lower secondary education, the aim of Mathematics 1 is that:

the student teachers shall be prepared to teach mathematics in correspondence with the prevailing mathematics curriculum for primary and lower secondary education in a professional and reflective way, and give the student teachers a knowledge base that enables them to further develop their knowledge and ways of working. (Ministry of Education and Research, 2003, p. 25, my translation)

The national framework presents for the compulsory mathematics course three content areas: academic knowledge of mathematics and didactics of mathematics; being a mathematics teacher; and, interaction and reflection (equivalent content areas are defined for the study units Norwegian, and Religious and Ethical Education).

The study plan for Mathematics 1 (The Faculty Board, 2003) is a local implementation of the national framework for mathematics in teacher education for primary and lower secondary education (Ministry of Education and Research, 2003). The academic components described in this study plan are the following: numbers; geometry; algebra and functions; and, statistics and probability. The target knowledge in the lessons I observed in my study was algebraic generalisation of patterns. I will in the following show how this topic is rooted in the study plan for the course in which the data were collected. A relevant theme under the subject area “numbers” is referred to as “different forms of numerical patterns (figurate numbers and other numerical sequences)” (The Faculty Board, 2003, p. 3, my translation). Under the subject area “algebra and functions”, the following themes are listed:

Simple functions and examples of how they can be used to describe among other things, processes in nature and everyday life; the connection between functions and algebra; basic understanding of the significance of the algebraic symbol

---

<sup>57</sup> For a detailed outline of the organisation and aims of the field practice in the teacher education programme, see Nilssen (2007, pp. 65-67).

language; the concept of variable, identified in functions as well as in equations; and, graphic expressions of functions and graphic solutions of equations. (The Faculty Board, 2003, p. 4, my translation)

The first theme, “how [functions] can be used to describe . . . processes in nature and everyday life”, is relevant for the observed lessons in the sense that shape patterns can be considered the result of what Alan J. Bishop (1988) refers to as *designing*. He claims that designing is one of six universal activities<sup>58</sup> which are carried out by every cultural group ever studied, and, further, that these activities are fundamental in the development of mathematical knowledge. Designing involves “creating a shape or design for an object or for any part of one’s spatial environment. It may involve making the object, as a ‘mental template’, or symbolising it in some conventionalised way” (Bishop, 1988, p. 183).

The second theme under the subject area “algebra and functions” from the study plan for Mathematics 1, “the connection between functions and algebra”, is relevant in the observed lessons of the following reason: The aim of two of the mathematical tasks with which the observed students engaged was to express the regularity of shape patterns in terms of a functional relationship between position and member of the sequence of numbers mapped from the shape pattern.<sup>59</sup> A third theme under “algebra and functions” is the concept of variable, which is central to the theme about “connections between functions and algebra”.

The main aim of the course Mathematics 1 is the students’ development of *relational understanding* (Skemp, 1976) of the topics they learn, in order to foster relational understanding of mathematics for pupils in school (The Faculty Board, 2003). Under the headline, “interaction and reflection”, the study plan describes that generation of mathematical knowledge often occurs in several phases, where the first phase is characterised by intuition, guess-and-check, eventual reformulation and new hypotheses. The next phase, according to the study plan, involves systematic work where general results are established through logical inferences. The tasks given to the students for collaborative work on algebraic generalisation of shape patterns I interpret as an implementation of the study plan according to the above mentioned subject areas, descriptions and competence aims.

---

<sup>58</sup> The other activities referred to by Bishop (1988) are counting, locating, measuring, playing, and explaining.

<sup>59</sup> The mathematical tasks are reproduced in Appendix A.

### 4.3.3 Student teacher participants

The six students who participated in my research were members of a class of 66 students. The six students constituted two practice groups. A practice group is a composition of three or more students which is established by the faculty administration for one academic year to have school-based learning in a particular class in primary or lower secondary school. Members of a practice group are also supposed to collaborate at the university college with respect to several types of tasks in different subjects. Each of the two practice groups that agreed to be my research participants consisted of three students; three females who belonged to one group (referred to as Group 1), and two females and one male who belonged to the other group (referred to as Group 2). An explanation of how the students were recruited is given in Section 4.4.2.

During the time the data for the research reported here were collected, the students were in the second semester of the teacher education programme. Tables 4.1 and 4.2 give an overview of the age, mathematical background, and proficiency indications of the students at the time the data were collected. This information was collected through a questionnaire filled out by the students. The names are pseudonyms. Courses are explained below the tables. The proficiency indications are: High marks (H); Middle-average marks (M); and, Low marks (L).

**Table 4.1. Group 1**

Name	Age	Mathematical background
Alice	20	1MA (M), 2MX (L)
Ida	21	1MA (M), 2MX (M), 3MX (M)
Sophie	22	1MA (M), 2MY (M), 3MY (M)

**Table 4.2. Group 2**

Name	Age	Mathematical background
Anne	21	1MA (H), 2MX (H), 3MX (H)
Helen	20	1MA (M), 2MX (M), 3MX (M)
Paul	26	1MA (H), 2MX (H), 3MX (M), MB110 (M) MB120 (L)

1MA: Compulsory course in mathematics (5 hours per week) during the first academic year in upper secondary school

2MX, 3MX: Voluntary courses in mathematics (5 hours per week) during the second and third year in upper secondary school, preparing for further studies in natural sciences and mathematics.

2MY, 3MY: Voluntary courses in mathematics (5 hours per week) during the second and third year in upper secondary school, preparing for further studies in social sciences and economics.

- MB110 Compulsory mathematics course (6 ECTS credits) in a university college study programme of business administration.
- MB120 Compulsory statistics course (6 ECTS credits) in a university college study programme of business administration.

The mathematical background and proficiency of the students as shown in the tables above, indicate that all students, except for Alice, have attended voluntary mathematics courses over the two last years in upper secondary school with middle-average or high marks. Alice has attended a voluntary mathematics course only in her second year in upper secondary school from which she has achieved a low mark. On the basis of the students' marks from upper secondary school, Group 1 can be considered middle/average strong, whereas Group 2 can be considered strong. Paul has, in addition to the mathematics courses in upper secondary school, taken two mathematics courses in business administration;<sup>60</sup> one with an average mark, the other with a low mark.

#### **4.3.4 Mathematics teacher participants and organisation of the mathematics teaching**

During the three semesters the mathematics course ran, the class was taught mathematics by three teachers: one male senior lecturer with more than thirty years of practice as a teacher educator in mathematics; one male professor with more than ten years of practice as a teacher educator in mathematics; and, I who had a minor teaching responsibility in the course.

Mathematics lessons in the class where I collected the data were conducted by two of the three mathematics teachers who were responsible for the course.<sup>61</sup> For each lesson, the two teachers responsible were both present. The classroom used was large and divided into two parts (of different sizes) by movable walls. There were four to six mathematics lessons each week (each lesson lasts for 45 minutes), mainly placed within one day. The most common organisation of the mathematics teaching was in the form of an introduction where all students were gathered in

---

<sup>60</sup> Paul had attended a three-year business administration programme at a university college before he was enrolled on the teacher education programme.

<sup>61</sup> The teaching pair depended upon the content taught and the share each teacher had on the course.

the biggest part of the classroom.<sup>62</sup> The introductory part would normally contain some information or stimulation before the class was split in two parallel groups. Sometimes the introduction was a lecture given by one of the teachers, other times it was a whole-class discussion, or a review of previous tasks. The introductory part was followed by two parallel group lessons each led by one of the two teachers, one in each part of the classroom. The two parallel group lessons had several formats: collaborative small-group lessons; lectures combined with discussions; or, review of previous tasks solved by students. When the students, placed in two different parts of the classroom, worked together in small groups on tasks designed by one of the teachers, the two teachers took a collective responsibility for all groups. That is, the teachers moved around the whole classroom, communicated with and helped students, irrespectively of where the groups were placed.

Teacher Erik<sup>63</sup> was responsible for the lessons on algebra which I observed and video recorded for the purpose of the research reported here. The responsibility included design of tasks and division of labour. Teacher Thomas, his partner, collaborated on the role of “teacher assistant” in the orchestration of the students’ work and shared the task of helping students during collaborative engagement with the given tasks. I had no teaching duties in the class during the period the data were collected. The students whom I observed were, during my observations, placed in a small room adjacent to the classroom (it was a separate room, not just divided by the movable walls). The purpose of this arrangement was to reduce the background noise on the video recordings. The observed students were informed that they could at any time go and ask for help or get suggestions from the teachers or peer students in the large classroom where the rest of the class worked in small groups on the same tasks. The teachers also, on their own initiative, went occasionally to the room in which the observed students worked.

A considerable part of the teaching time was spent on small-group lessons in the mathematics course. It was therefore interesting for me to get insight into the outcome of these lessons in terms of what the students appropriated of mathematical knowledge, or did not appropriate in those lessons, and why.

---

<sup>62</sup> One part of the classroom had tables and chairs for all 66 students.

<sup>63</sup> Teachers’ names are pseudonyms.

In the next section I return to a discussion of the research methods.

## 4.4 Research methods

### 4.4.1 Style of inquiry

In my study I wanted to expose evidence about “how” and “why” students’ opportunities to establish algebraic generality in shape patterns are constrained. The data I needed for this to be done were the mathematical tasks given to the students, and observation of didactical situations in which students engaged with these tasks. This is a contemporary event over which I had little control (as explained in Section 4.3). These factors led me to the choice of a case study method. Robert K. Yin (2009) claims that case studies are the preferred research method when asking “how” and “why”<sup>64</sup> questions, and the focus is on “a contemporary set of events over which the investigator has little or no control” (p. 13).<sup>65</sup> Hence, the criteria proposed by Yin to legitimise the selection of a case study as style of inquiry were present in my research.

Lawrence Stenhouse (1988) has identified four types of case study: ethnographic; evaluative; educational; and, action research case studies. His characteristic of an *educational case study* matches with the intention of my project:

Educational case study [is where] many researchers using case study methods are concerned neither with social theory nor with evaluative judgement, but rather with the understanding of educational action. They may adopt a strategy close to that of the ethnographer (Smith and Keith 1971) or close to that of the evaluator (Hamilton 1977). They are concerned to enrich the thinking and discourse of educators either by the development of educational theory or by refinement of prudence through the systematic and reflective documentation of evidence. (Stenhouse, 1988, p. 50)

---

<sup>64</sup> The “why” questions referred to here are not to be interpreted in a positivistic meaning as explaining cause and effect. The purpose is to understand why something happened in a particular context.

<sup>65</sup> Yin (2009) expresses that also experimental studies and historical studies are methods used to answer “how” and “why” questions. However, these methods are different from case studies with respect to the extent of control an investigator has over actual behavioural events, and the degree of focus on contemporary as opposed to historical events: Experimental studies focus on contemporary events, but require control over behavioural events; historical studies require no control over behavioural events, but do not focus on contemporary events.

I selected an educational case study (Stenhouse, 1988) with two cases as mode of inquiry. This makes it a *collective* case study (Stake, 1995). Each case involves a practice group of three students. An important feature of a case study is that it has been conducted within a localised boundary of space and time (Bassey, 1999). This is accomplished in my study because I have studied each practice group as its participants engaged collaboratively in eight small-group lessons on algebra at the university college.

Rather than the purpose of learning about the intrinsic properties of these particular cases, I use the cases as instruments to get a general understanding of the complexity of students' algebraic generalisation of shape patterns. This purpose of a case study is consistent with the type of case study that Robert Stake (1995, 2005) refers to as an *instrumental* case study. He explains that an instrumental case study is where

a particular case is examined mainly to provide insight into an issue or to draw a generalization. The case is of secondary interest, it plays a supportive role, and it facilitates our understanding of something else. The case still is looked at in depth, its contexts scrutinized and its ordinary activities detailed, but all because this helps us pursue the external interest. (Stake, 2005, p. 445)

Michael Bassey (1999) refers to a case study with features consistent with an instrumental case study as a *theory-seeking* case study, "aiming to lead to fuzzy propositions (more tentative) and fuzzy generalizations (less tentative) and conveying these, their context and the evidence leading to them to interested audiences" (p. 58). A "fuzzy generalisation" has a built-in uncertainty; it recognises the likelihood of there being exceptions (Bassey, 1999). According to Bassey, the concept of fuzzy generalisation is appropriate in educational research where human complexity is of the greatest importance. He explains the concept in these words:

[A fuzzy generalisation] reports that something has happened in one place and that it may also happen elsewhere. There is a possibility, but no surety. There is an invitation to "try it and see if the same happens for you". (Bassey, 1999, p. 52)

The intention with the research reported here is to present a fuzzy generalisation by reporting from my educational case study what factors constrain students' establishment of algebraic generality in shape patterns. It is also a purpose to explore the power of the theory of didactical situations in mathematics to expose critical features of teaching and learning mathematics on a teacher education programme.

#### **4.4.2 Selection of site and research participants**

The class from which participants were recruited to my study was chosen by default. The reason is that my research funding was limited to the programme for teacher education with emphasis on mathematics and science subjects at the university college where I had been employed the



previous four years. In the academic year I started the research project, 66 students (constituting one class) were enrolled at the programme from which my research participants were recruited. There were two mathematics teacher educators in this class, in addition to me. They were willing to participate in the research and agreed to be observed and video recorded during mathematics teaching.

As explained above, my case study consists of two groups (cases). There were two reasons for choosing to have more than one case in my project. First, I wanted to raise the chance of gathering empirical material that contained sufficient interesting events and situations, which could provide evidence for analytical statements (hypotheses) made through the analysis. Because I did not know much about the practice groups in advance, and I thought that “interesting events and situations” with respect to my research questions, depended on the quality of the group work, I considered it a good idea to observe more than one group. Second, I thought of the vulnerability of having just one group in case some of the students in that group dropped out of the teacher education programme. The reason why I chose not to have more than two cases was about manageability, both with respect to practical issues (e.g., collecting empirical material) and the analytical process.

In the autumn 2003 I gave information about my research study to the class in which the potential research participants were members. I explained what I planned to inquire into, and what the intention of the project was. I expressed that I wanted to cooperate with two practice groups from the class during their second and third semester at the teacher education programme, and informed them about what that cooperation would involve and what requests there were to the participants. The most thorough requirement I had to the research participants was that they had to be in the same practice group and have school based learning in the same class for two instead of (as normally) one academic year. I will return to a comment on this requirement (under the headline *Progressive focusing*) after the presentation of additional requirements to the student participants.

A second requirement was that potential participants had to have the intention of taking part in (almost) all mathematics lessons at the university college. The first and second requirements were based on the need to have a continuous and prolonged engagement with the actions of the cases. A third requirement was that I wanted to observe practice groups which functioned well. An ill-functioning group of students I presumed would be a disturbance for the possibility of observing collaborative generalisation processes. A fourth requirement was the willingness of the research participants to be observed and video recorded during engage-

ment with algebraic tasks at the university college and during algebra teaching in the practice field.

After information was given about the project and requirements to student participants, I asked all practice groups to sit together and discuss if they would be interested in cooperating with me. I then asked members of groups that might be interested, to write (individually) briefly about their former education in mathematics, intentions with respect to presence at mathematics lessons (presence is generally voluntary at the university college), and how they assessed the functioning of the practice group. The result was that three groups were interested and willing to be my research participants based on the premises described above. Based on what the students had written concerning group functioning, I concluded that two groups met my purposes. When one of these groups later regretted their agreement, I asked another group directly if they were willing to participate. This group I chose on the basis of the impression I had formed of them as rather conscientious with respect to their studies. The students in this group agreed to stay in the same practice group the subsequent year, but hesitated to agree about having school based practice in the same class. Their rationale was that they believed they would learn more if they had school-based learning in a new class the next year, an argument I found reasonable. Hence, I relaxed the requirement for both practice groups of having school based practice in the same class during the first two years at the programme. The students and teachers participating in the study have been presented in Section 4.3.3 and Section 4.3.4, respectively.

#### *Progressive focusing*

When I planned the project, the intention was to find answers to two questions: First, what factors constrain student teachers' algebraic generalisation processes? Second, what factors are of importance for student teachers' design and implementation of algebra teaching in the practice field? The intention was to try to find relationships between, on the one hand, the student teachers' engagement with algebraic tasks at the university college, and their engagement with algebra teaching in the practice field, on the other. I planned for (and accomplished) data collection in the practice field during the second and third semester of the programme. This was the background for the requirement that the recruited practice groups (and schools) were the same during the first and second academic years.

However, in this dissertation I report only from the analysis of the material collected at the university college, with respect to the first research question. The reason for this is two-fold. First, the data collected from the practice field turned out to be less suitable to answer the second research question. It was complicated to ensure opportunities for algebra

teaching for the students in the practice periods. It was necessary to attend to the one-year plans already developed by the regular class teachers for mathematics content in the practice periods. In retrospect I realise that it would have been essential to negotiate with the class teachers at an early stage about content in the practice periods (and potentially about what algebra teaching may involve).

Second, findings from the analysis with respect to the first research question were quite extensive. Presenting findings with respect to another research question<sup>66</sup> would not be feasible in order to contain this report within reasonable boundaries of length, and ensure sufficient depth. Hence, I report from findings related to the research question which addresses constraints to students' appropriation of algebraic generality in shape patterns, as discerned in the data collected from students' collaborative engagement with mathematical tasks at the university college.

In the next section I present an account of the data sources and how they are collected. The data referred to are only those collected to answer the research question about constraints to students' establishment of algebraic generality in shape patterns.

#### **4.4.3 Data sources and instruments used to collect data**

Case study research has no specific methods of collecting data or of analysis which are unique to it as a method of inquiry: "It is eclectic and in preparing a case study researchers use whatever methods seem to them to be appropriate and practical" (Bassey, 1999, p. 69).

##### *Data sources*

I have chosen two main sources of data and a secondary source which is used in a *methodological triangulation* (Denzin, 1978). The primary source of data is eight small-group lessons at the university college, in which the students engaged collaboratively (in the practice groups) on algebraic generalisation of shape patterns. A second source of data is four mathematical tasks (each constituted by several subtasks) on algebraic generalisation of shape patterns with which the students engaged during the eight observed lessons (the tasks are reproduced in Appendix A). A third source of data, which is secondary to the first two sources, is three conversations with teacher Erik who had designed the mathematical tasks for the observed lessons.

---

<sup>66</sup> Presuming that the data from the practice field would make it possible to answer other research questions than the one originally posed.

The eight lessons (11 hours of video recordings) which constitute the primary data source were the first lessons on algebra in the mathematics course and the only lessons these students had on algebraic generalisation of shape patterns.<sup>67</sup>

#### *Instruments used for collecting data*

Material from the students' collaborative engagement with the mathematical tasks was collected in terms of observations which were recorded on video tapes.<sup>68</sup> The mathematical tasks were collected in terms of files which I downloaded from the website of the mathematics course.<sup>69</sup>

Conversations with teacher Erik, who was responsible for the observed lessons and the one who had designed the mathematical tasks, were recreated in my research journal (i.e., they were not audio- or video recorded). The first two conversations were short conversations about the aim of the designed tasks and other emergent topics related to the observed lessons. They were recreated the same day after the conversations took place. The third conversation was about the interpretation of one of the observed episodes as reported in a paper I had written (Måsøval, 2005). This conversation was about the impact the paper had on him who was the teacher participating in the analysed episode. I wrote notes from this conversation simultaneously as it took place.

#### **4.4.4 My own role during data collection**

During the period of data collection at the university college, I did not have teaching obligations in the class where the research participants were enrolled. For the research participants, I defined my role during data collection to be a silent observer, not enabling myself to take part in the classroom or in the students' work. The reason for this was that I wanted the observed situations to be as natural as possible, acknowledging though that my observation of their engagement was in itself a disturbance. If I had been available for help and discussions with the stu-

---

<sup>67</sup> There were several lessons in the mathematics course on algebra and functions succeeding the observed sessions. These were not on generalisation of shape patterns.

<sup>68</sup> The video tapes were stored (labelled with information about the observed event) in my office for display and transcription. A file was created in which I recorded a schedule of the observed sessions (date, time, students, tasks).

<sup>69</sup> On the website of the mathematics course the activities in all mathematical topics were published (plans, notes from lectures, assignments, and mathematical tasks). The content of the website as it appeared at the end of the course (with all elements recorded), I stored on a CD-ROM. The website showed that the students had no algebra lessons before those that I observed.

dents during their work, they probably would have considered me to be an external authority (in addition to the teachers who were responsible for the observed lessons), which they could, or was expected to, consult. That would disturb the natural setting which was based on their collaboration in the group with the possibility to consult the teachers in charge as well as peer students if they found it necessary or desirable.

#### 4.4.5 Unit of analysis

The classroom is a place where knowledge is appropriated through various processes, in particular through situations that contextualise knowledge and through interactions about and with this knowledge amongst teacher and students who act within and on these situations (Laborde & Perrin-Glorian, 2005). Teaching and learning in the classroom is at the same time part of a broader social project, that of “educating future citizens according to cultural, social and professional expectations” (Laborde & Perrin-Glorian, 2005, p. 1; see also, Herbst & Kilpatrick, 1999). In view of the macrolevel of the global educational system and the microlevel of individual learning processes, Laborde and Perrin-Glorian (2005) claim that at an intermediate position between these levels, “the classroom teaching situation constitutes a pertinent *unit of analysis* for didactic research in mathematics, that is, research into the ternary didactic relationship which binds teachers, students and mathematical knowledge” (Laborde & Perrin-Glorian, 2005, p. 1). Based on reports from empirical studies published in Laborde, Perrin-Glorian, and Sierpiska (2005), Laborde and Perrin-Glorian (2005) observe that the size of the classroom teaching situation as a unit of analysis seems to be appropriate to study didactic phenomena which play a role in the multifaceted complexity of the interrelations between the teaching and learning in school.

In my investigation of factors that constrain students’ establishment of algebraic generality in shape patterns, I define the small-group teaching situation as the unit of analysis when I examine the interplay between the teacher, the students, and the mathematical knowledge at stake. The small-group teaching situation, conceptualised as a *didactical situation* (Brousseau, 1997), is analysed from the perspective of the different phases of a didactical situation (situations of action, formulation, validation, and institutionalisation), where the concept of milieu is crucial (see Figure 4.1 in Section 4.1.1 for an illustration of the different parts and the relationships between them in the didactical situation).

In the next section I explain how I have conducted the analysis of the data.

#### 4.4.6 Methods for analysis of data

*The first approach to the data including analyses of the mathematics potential in the tasks on shape patterns*

The process of data analysis started after the fieldwork was completed. I made a brief overview of possible solutions to the tasks on algebraic generalisation of shape patterns (some of the tasks had several solutions; some had several paths to a solution). After I had transcribed the video recordings from the classroom observations, I read the transcripts (total of 147 pages; 3462 turns).<sup>70</sup> I tried to get a sense of what was going on and how, with respect to the students' engagement with the mathematical tasks on shape patterns. That is, I examined how the students interpreted and solved the tasks, and what was challenging for them in terms of solving them. After I had read the transcripts, I made a brief overview of each group's solutions to the tasks (Appendix B).

In order to engage with the data, I felt a need to do more detailed analyses of the mathematics content in the tasks given to the students. This was essential to finding out what constrained students' algebraic generalisation processes. I therefore conducted epistemological and didactical analyses of the mathematical concepts present in the tasks and concepts that I interpreted to be relevant for the given tasks. The epistemological analysis has been pursued with the purpose of defining the terms used very carefully, attempting to achieve precision in language that is consistent with current mathematical convention. The didactical analysis is conducted to expose relationships between the intended mathematical knowledge and different approaches to algebraic generality in shape patterns. An elaborated version of the epistemological and didactical analyses is presented in Chapter 5.

*Methods for analysis of students' engagement with the mathematical tasks*

The first written account that I made from the transcripts was the brief overview of the outcome of the students' engagement with the tasks as mentioned above. Thereafter I worked through the transcripts and partitioned them into segments where each segment constituted a unit of meaning with respect to what the observed persons did and achieved, or

---

<sup>70</sup> The transcripts were segmented in numbered turns, where a turn is defined as the set of utterances made by a person until another person takes a turn. The transcriptions were made in Norwegian, except the first lesson of Group 1, which was transcribed in English.

not achieved, in relation to the intentions of the tasks. The interpretations of meaning in the segments were written on post-it notes which I adhered to the margin of the transcript, beside the turns they represented. The use of post-it notes gave me more space to account for the interpretations than would marginal remarks have provided (in case of many segments on a page, notes were adhered overlapping). The process of analysis constituted by dividing the transcripts into units of meaning I interpret to be a data reduction process according to Matthew B. Miles and A. Michael Huberman's (1994) definition of the concept. They refer to data reduction as

the process of selecting, focusing, simplifying, abstracting, and transforming the data that appear in written-up field notes or transcriptions. . . . Data reduction is a sort of analysis that sharpens, sorts, focuses, discards, or organizes data in such a way that "final conclusions" can be drawn and verified. (Miles & Huberman, 1994, p. 10)

In the following I will refer to the accounts written on the post-it notes as *explanatory notes*.

The next step in the analytic process was that I examined the reduced data (the explanatory notes) with the aim of making a *data display* (Miles & Huberman, 1994). In this process I *coded* the data chunks represented by the explanatory notes which were significant with respect to my research question.<sup>71</sup> While I was coding I wrote *theoretical memos*, that is, "theorizing write-up[s] of ideas about codes and their relationships" (Glaser, 1978, p. 83).

The data display was made in the form of four matrices; for each of the two groups, I made a matrix for each of the two days with algebraic generalisation of shape pattern. The matrices had three columns: The first column consisted of codes that conceptualised the data segments identified as significant with respect to the research question. The second column displayed the excerpts from the transcript that the code represented. The third column displayed the numerals representing the numerical orders of the turns that the codes represented. The rows were established by significant segments from the data; they were identified by epi-

---

<sup>71</sup> In making the explanatory notes, I had represented what the persons did and achieved with respect to the mathematical tasks, with the aim of finding out what was going on, and how. Not all segments into which the transcripts were partitioned were significant with respect to my research question. In the data display process I only coded the segments that I interpreted to give insights into factors which constrained the students' establishment of algebraic generality in shape patterns.

sodes which I interpreted as in some way significant with respect to constraining the students' algebraic generalisation processes.

When I went through the process of displaying the data this way, I constantly compared emerging codes with existing codes and went back to refine codes in order to capture their meaning better and more economically (trying not to introduce unnecessarily fine grained codes). In this process I drew on both the theoretical memos and the epistemological and didactical analyses that I had conducted of the mathematics potential in the tasks. Examples of codes in the data display are: "focus on number of components instead of structure"; "insecurity related to the concept *mathematical statement*"; "problems with the syntax of algebra". Each matrix spanned from 7 to 11 pages.

The next stage consisted of going through the matrices and conducting a conceptual interpretation where I used Brousseau's theory of didactical situations in mathematics as a framework. This conceptualisation was made in the form of categorising the codes in the data display, using concepts from the theory of didactical situations. These categories were written as notes at each row in the margin of the matrices. Afterwards, categories were compared and collected into groups, distributed with respect to the role each category played in the didactical situation. From this process, three main groups emerged. These groups are referred to as *core categories* which are labelled according to their significance in the didactical situation. Rather than being mere labels, these categories are conceptualisations of key aspects of the data. According to Ian Dey (2004), they are therefore *analytic* categories. The core categories are: *Constrained feedback potential in didactical situations*; *Complexity of turning a situation of action into a situation of formulation*; and, *Complexity of operating in the situation of validation*.

The categories that were collected under the core categories are referred to as *subcategories*. They explain the core categories (hereafter referred to as just *categories*) in the way they offer purposeful interpretations of the phenomenon under investigation; that is, constraints to students' algebraic generalisation of shape patterns. Through constant comparison, properties of and relationships between subcategories have been identified and refined. The subcategories are further illustrated by *events* which are characteristic of the subcategories. The events are circumstances in which the subcategories are manifested. The categories with subcategories and events will be presented in Chapters 6, 7, and 8. The headline of each of these chapters is the same as the title of the category that the chapter presents. The same applies for the subcategories and events; headlines of sections and subsections correspond to the respective subcategories and events. Illustrations of the categories with subcat-



egories and events are provided in Figure 4.4, Figure 4.5, and Figure 4.6 (presented on the following pages).

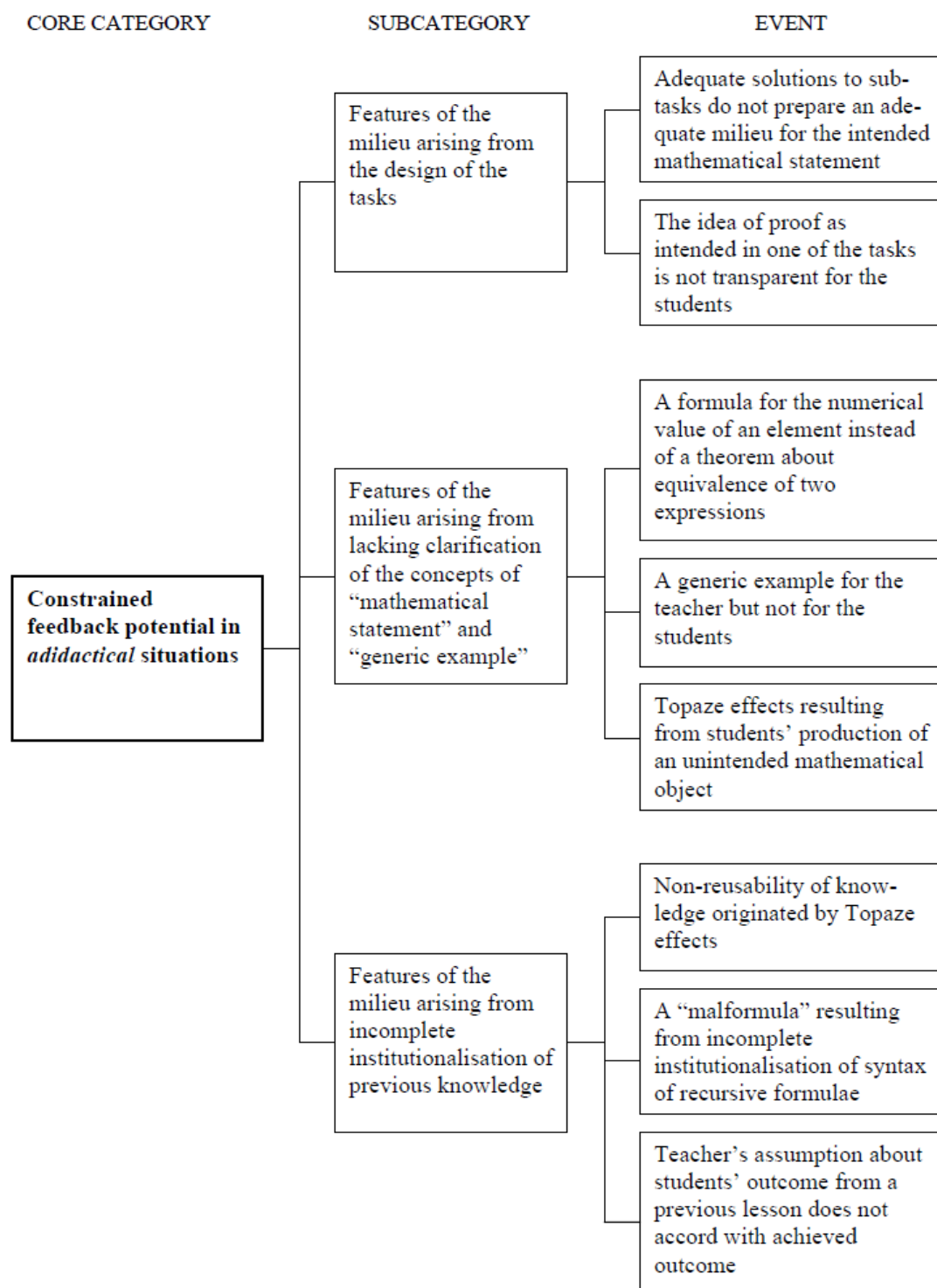

Figure 4.4. The core category *Constrained feedback potential in didactical situations* with its subcategories and events (the category will be presented in Chapter 6)

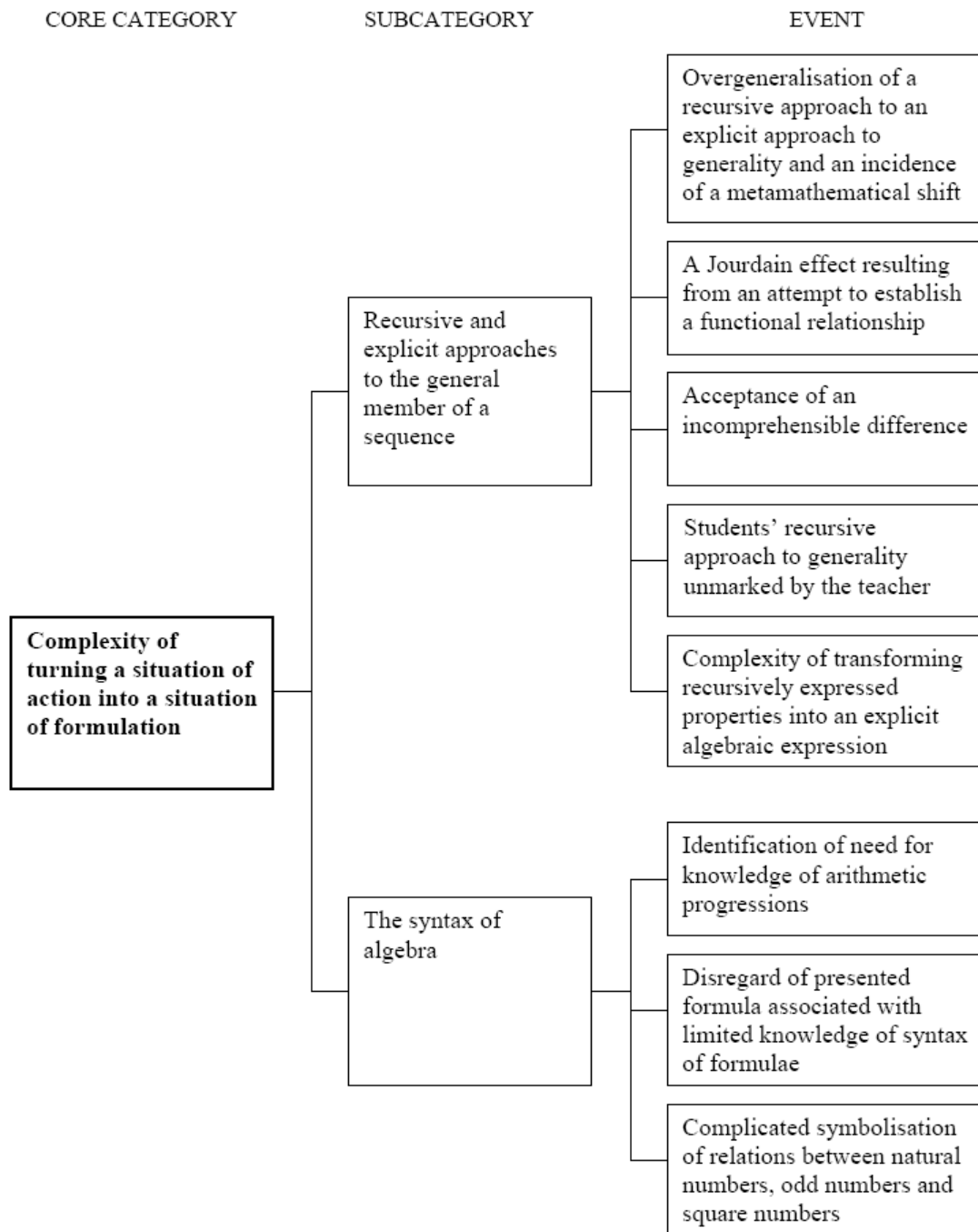

Figure 4.5. The core category *Complexity of turning a situation of action into a situation of formulation* with its subcategories and events (the category will be presented in Chapter 7)

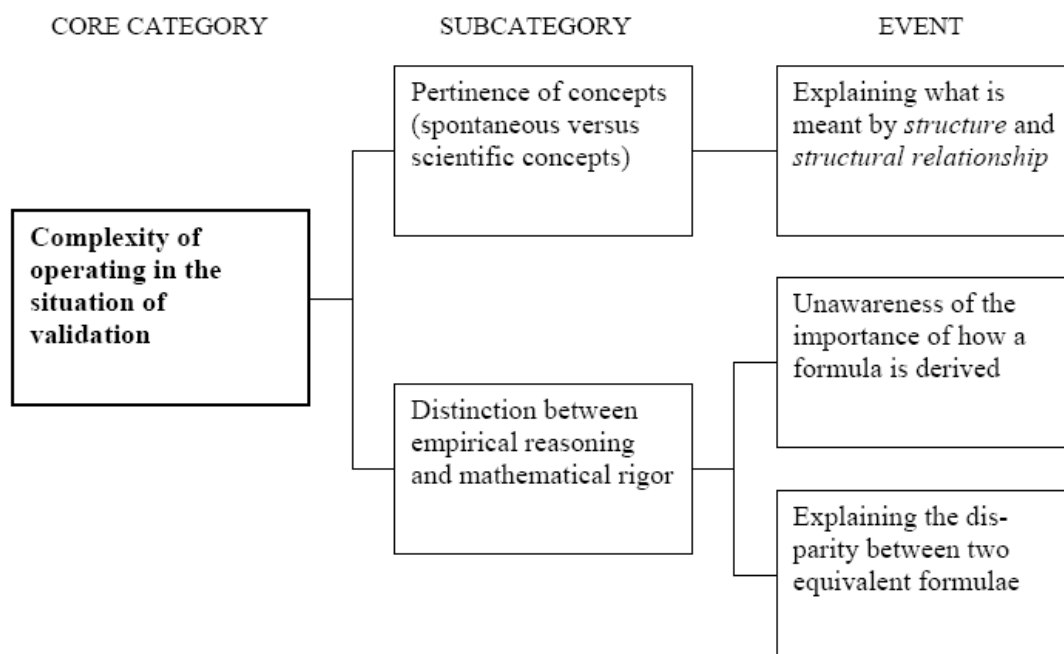

Figure 4.6. The core category *Complexity of operating in the situation of validation* with its subcategories and events (the category will be presented in Chapter 8)

*A comment on relationships between the employed methodology and the sociocultural framework that underpins the research*

Vygotsky (1930/1997b) argues that a scientific study of mental processes (as in my study) must focus on the unity of those processes, rather than on their elements separated by temporal interruptions:

Indeed, mental life is characterized by breaks, by the absence of a continuous and uninterrupted connection between its elements, by the disappearance and reappearance of these elements. Therefore it is impossible to establish causal relationships between various elements and as a result it is necessary to refrain from psychology as a natural scientific discipline. . . . We must not study separate mental and physiological processes outside their unity. We must study the integral process which is characterized by both a subjective and an objective side at the same time. (pp. 111-113)

René Van der Veer (2001) draws on Vygotsky (1931/1997a) when he identifies three interconnected requirements for an analysis of higher mental functions which is holistically as suggested in the quotation above. The researcher should: 1) distinguish the analysis of things from the analysis of process; 2) focus on the genesis of action; and, 3) distinguish between explanatory and descriptive tasks of analysis (Van der Veer, 2001).

In my search for factors that constrain students' appropriation of algebraic generality in shape patterns, I have chosen the didactical situation as unit of analysis (as explained in Section 4.4.5). This analytical unit preserves the essence of the *whole* (the students' appropriation of

the target knowledge) in that I interpret the knowledge appropriated by the students as properties of the interactions (relationships) between the student and the milieu (the subset of the environment with only those features that are relevant with respect to the target knowledge). In the analysis I have taken an epistemological approach which means that the focus has been on the students' *possibilities* to learn rather than their actual learning. This approach has been carried out by distinguishing between, on the one hand, the analysis of *things* (the mathematical knowledge) and on the other, the analysis of *process* (the interactions between the student and the milieu; see Section 4.1.1). The analysis of things comprises epistemological and didactical analyses of the mathematics potential in the tasks, where mediational means are an integral part (e.g., concepts, notation, geometrical configurations, and diagrams). The analysis of process involves the analysis of video recorded classroom observations, where the students and the teacher interact in the didactical situation with the purpose of the students' appropriation of algebraic generality in shape patterns.

My aim has been to understand what factors have constrained students' opportunities to appropriate algebraic generality in shape patterns in the actual *context*; it has not been to establish general laws of relationships that constrain algebraic generalisation processes. This has been essential to my choice of an idiographic research methodology. I have tried to *explain* factors constraining students' appropriation of the target knowledge in that I have exposed relationships between the milieu in which the students engaged and the outcome of the students' engagement. This has been done from the perspective of trying to uncover the genesis of the constraints the students encounter in their appropriation of the target knowledge.

In the next section I discuss ethical considerations made in the research reported here.

#### **4.4.7 Ethical issues**

The research reported in this dissertation has been registered at Norsk Samfunnsvitenskapelig Datatjeneste (Norwegian Social Science Data Services) with project number 18044. Three basic ethical principles are important in research with "human subjects": informed consent in recruitment; avoidance of harm in fieldwork; and, confidentiality in report-

ing (Flinders, 1992).<sup>72</sup> These principles are consistent with the guidelines presented in The National Committee for Research Ethics in the Social Sciences and the Humanities (2006), which I have followed in the research reported here.

### *Informed consent*

Informed consent is referred to as “the procedures in which individuals choose whether to participate in an investigation after being informed of facts that would be likely to influence their decisions” (Diener & Crandall, 1978, as cited in Cohen et al., 2007, p. 52). As described in Section 4.4.2, I informed the class from which my research participants were to be recruited, about my project. It was done in terms of a presentation where the students were invited to make comments and pose questions. The presentation was made on the basis of a document with the main issues as seen at the time the information was given (this document is reproduced in Appendix C). Information was given about these aspects: intention with the project; research style; data sources and data collection methods; time commitments; who would have access to the collected data; confidentiality; and, requests to research participants.

After this information was given, the participants were recruited as described in Section 4.4.2, and a consent form (Appendix D) was signed by each student. This form made clear that they were free to withdraw from the project at any point of time. The teachers were, in the same way as the students, informed about the project, but were not given a consent form to sign. They only gave their oral consent to collaborate with me. The reason why I treated the teachers and students differently with respect to consent was that the intention with the project in the beginning was to focus on the students’ collaborative engagement with algebraic tasks. But when I analysed the data, I saw that the teachers’ approach (including the mathematical tasks) was important in order to answer the research question as it developed after a process of *progressive focusing* (Parlett & Hamilton, 1976).

In addition to consent to participate in the project, consent was given by each student to let me use excerpts from the data (video recordings and transcripts) for instructional or scientific purpose (Appendix E). Again, consent from the teachers was given orally.

---

<sup>72</sup> These principles are aspects of research which fall under the ethical framework conceptualised as *utilitarianism* (Flinders, 1992).

### *Debriefing*

According to Joan E. Sieber (1992), debriefing, defined as “providing an opportunity for interaction with subjects and relevant others immediately following the research participation” (p. 39), is important. I had one video session with each group, where we looked at extracts from the video recordings. The aim was two-fold: First, I considered it relevant to get insights into the students’ rationale for what they did (and did not do) in the episodes; that they might explain from their perspective what was going on, and why. Second, I wanted to give the students an opportunity to look at extracts from the collected data (video recordings), transcripts and pre-analytic accounts of the chosen extracts in order for them to get a sense of how their actions appeared on the video, how the observations were transformed into texts (transcripts), and how the outcome of the analysis might look. The second aim was in respect for the students’ well-being.

After I had seen the video recordings from the first two days of data collection, I chose one episode from each group which I interpreted to be significant with respect to my research question. I transcribed these episodes and did a preliminary analysis of what was going on. Theory was used to illuminate the incidents, and short analytic accounts were written for each of the episodes. The transcripts together with the preliminary analytic accounts were sent to the respective group members before we had video sessions, one with each group. In the video session, the students expressed that it was strange to see themselves in the video, and that it was interesting to see how the episodes were transformed into texts. One of the groups expressed that they had felt rather unsuccessful during the observed episode and that it was embarrassing for them to be observed and video recorded. I explained that my aim was to find obstacles to their algebraic generalisation processes and that the episode therefore was significant. I explained that I understood that they felt unsuccessful (they had engaged with a task for quite a long time without getting at a solution). I pointed at a factor which I interpreted to be crucial for the lack of progress; that the students focused on a recursive formula, whereas the teacher focused on an explicit formula, of which neither the teacher nor the students seemed to be aware. For me it was important to convey to the students that neither they nor the teacher were to be “blamed” for the lack of progress, and that I did not want to put any of them in “deficit” mode in the research report. A year later I sent to the students in this group a paper which I wrote based on the mentioned episode (Måsøval, 2005). Their reaction was that it was “exciting to be in a paper”. Because the only research reported in which observations from the other group are used, is this dissertation, the students of that group

have not been afforded a paper that reports from observation of their engagement with the mathematical tasks.

The teachers have not been debriefed through video sessions as the students. As noted earlier, in the beginning of the project, my focus was on the students and their collaborative engagement with mathematical tasks in groups. It was not teaching in the sense of instruction that I wanted to focus on, but the students' learning in small groups. Therefore, I did not consider the teachers as relevant in the same way as the students. Later, I found it relevant to take the didactical situation as the unit of analysis, a decision which implied that the teaching became significant.

What the teachers have been afforded from the project in terms of potential beneficence, are the papers published from the research (Måsøval, 2005, 2006, 2007, 2009; Goodchild, Jaworski, & Måsøval, 2007). In a conversation with me (on 26 September, 2005), teacher Erik explained that the research in which he had participated had made an impact on him as a teacher. He claimed that the findings reported in Måsøval (2005) were significant for the way he interacted with students in a mathematics class some months after he had read the mentioned paper. Erik said that he had become more aware of listening carefully to the students and trying not to practice "funneling" (scaffolding in a way that reduces the mathematical challenge of the given task; Bauersfeld, 1988).<sup>73</sup> Below I provide an excerpt from the same conversation which points at how the theoretical framework used to analyse the dialogues had been significant for Erik: First, Erik asserts that the theory helped him to understand better what was going on in the dialogue (turn 7). Second, he asserts that he got a better grasp of the theory because it was related to himself as a participant in the analysed episode (turn 9). (For transcription codes, see Appendix F).

- 3 Teacher Erik: It was your analysis of the previous episode [reported in Måsøval, 2005] that had a strong impact on me.
- 4 Heidi: In what way did it have a strong impact?
- 5 Teacher Erik: When I read your paper [Pause 1-3 s] that was the first thing. I was not at all aware that I behaved in that manner. It became so obvious when I read the dialogues. When I was in the middle of the activity, I didn't realise that they [the students] searched for a recursive formula.

---

<sup>73</sup> Funneling conceptualises the same phenomenon as the Topaze effect (Brousseau, 1997).

- 6 Heidi: How did the impact [from the paper] develop?  
7 Teacher Erik: It was like, in a way I didn't recognise the situation. Was it really like that? But it was also a strong impact how this, the theory from Bauersfeld and Brousseau, contributed to the fact that I understood better what happened in the dialogue [Pause 1-3 s]  
8 Heidi: Why did you read Brousseau and Bauersfeld?  
9 Teacher Erik: It was supposedly because you began to read Brousseau, and then I read Bauersfeld because I read the paper, and you referred to this theory. The theory became much more meaningful to me when I got it related to myself.

[Conversation with teacher Erik, 26 September, 2005]<sup>74</sup>

I would like to remark that researchers cannot expect that research participants will be interested in, and prioritise to use time on, engagement with the theoretical framework that underpins the research inquiry in which they participate, like Erik did.

#### *Avoidance of harm*

I have applied the theory of didactical situations in mathematics (Brousseau, 1997) to analyse the collected data. Brousseau's (1997) framework, as described in Chapter 2, is a scientific approach to the set of problems posed by the teaching and learning of mathematics, in which the specificity of the knowledge taught is engaged and plays a significant role (Brousseau, 2000). As argued in Section 2.5, the theory of didactical situations is neither a method of teaching nor an ideology. Nevertheless, as noted by Brousseau (e-mail cited by Sierpinska, 1999, Lecture 8), the theory can provide some methods of teaching mathematics, it can legitimise some methods and render some other methods unsuitable. For this reason I have faced a tension caused by the fact that the theory of didactical situations in mathematics has not informed the teachers' preparation of and methods used in the observed lessons. However, as explained in Chapter 2, the theory of didactical situations in mathematics provides models and concepts that make it possible to analyse and communicate what is going on in the mathematics classroom in terms of the interplay between the students, the teacher, and some particular mathematical knowledge. I have used the theory as a scientific approach to the complexity of teaching and learning of algebraic generality in shape patterns.

---

<sup>74</sup> The conversation was transcribed by me at the same time as the conversation took place. The excerpt included above is translated into English by me.



I have analysed what I have observed; it has not been my aim to make value judgements of the teaching or of the students' engagement according to the concepts and models of the theory of didactical situations. (See Section 2.5 for a discussion of the legitimacy of using Brousseau's theory in my research inquiry).

Because the knowledge taught plays a significant role in the theory of didactical situations, in my analyses I have drawn on epistemological and didactical analyses of the target knowledge (presented in Chapter 5). These analyses I accomplished after the data were collected, which means that they were not shared with the teachers before the observed lessons were prepared and conducted.

My focus has been on factors that constrain students' algebraic generalisation processes. Naturally, I have identified aspects of the teachers' approaches (including task design) which I have interpreted as constituting constraints to the students' appropriation of algebraic generality in shape patterns. It has been challenging to present the outcome of the analyses without seeming to be critical of the teachers. The fact that the theoretical framework and the epistemological and didactical analyses of the target mathematical knowledge did not inform the teachers' preparation and conduct of the observed lessons, constituted a tension. I did not want to present analytic findings that could be giving an impression that the teachers were interpreted as lacking essential competencies. At the same time I needed to give insights into the nature of the complexity of teaching and learning mathematics, because that was what my research inquiry was about.

Another reason for the discernible conflict between wanting not to do harm to the teachers on the one hand, and conveying the complexity of teaching mathematics on the other, has been that I conducted the research in my own professional milieu. This implies that absolute confidentiality has been impossible. Other implications are the possible strains on relationships between me and my colleagues, the vital importance of remaining non-judgemental, impartial and objective.

A point I want to make is that the design of my study and the chosen theoretical framework entailed that my ethical considerations with respect to avoidance of harm had to be far more stringent than the usual guidelines applied.

### *Confidentiality*

Confidentiality refers to agreements with research participants about what can be done with the collected data (Sieber, 1992). According to Sieber (1992), the confidentiality agreement between a researcher and a participant is part of the informed consent. In the consent signed by the students in my research it was confirmed that the data would be anonymised by use of pseudonyms in transcribing and in writing up the study.

In the information given to the participants, it was communicated that the video recordings would be seen only by the researcher, the supervisor and examiners. Later, I have been given consent from the participants to use excerpts from the video recordings for instructional and scientific presentation purposes (as described above).

Even if pseudonyms are used for the teachers' names, their anonymity has been harder to protect because they are presented in the dissertation as my colleagues.

In the next chapter I present the epistemological and didactical analyses of the mathematics potential of the tasks with which the students engaged.

# 5 Epistemological and didactical analyses of the mathematics potential in tasks on algebraic generalisation of shape patterns

In this chapter I present epistemological and didactical analyses of mathematical concepts embedded in the tasks with which the observed students engaged. The tasks are reproduced in Appendix A.

The purpose of the epistemological analysis is to define the terms used in the tasks and identify relationships between them. The purpose of the didactical analysis is to expose relationships between the intended mathematical knowledge in the tasks and different approaches to algebraic generality in shape patterns. The analyses have been conducted to enable me to inquire into factors that constrain students' establishment of algebraic generality in shape patterns.

## 5.1 Epistemological analysis

The epistemological analysis has been pursued with the purpose of defining the terms used very carefully, attempting to achieve precision in language that is consistent with current mathematical convention. However, it is recognised that many of the key words used, for example statement, formula, relationship, and so forth also have an everyday meaning. When students encounter these words in their study it is likely that they attach the everyday meaning, *even* if they have met the esoteric mathematical definition in their earlier studies.

### 5.1.1 Sequences and shape patterns

In order to explain the concept of sequence, it is necessary to define the concepts of "relation" and "function" first. In mathematics a *relation* is any subset of a Cartesian product; for instance, a subset of  $A \times B$ , called a binary relation from  $A$  to  $B$ , is a collection of ordered pairs  $(a, b)$  with first component from  $A$  and second component from  $B$  (Weisstein, 2009, Vol. 3, p. 3324). Robert R. Stoll (1963/1979) defines a *function* to be a relation that uniquely associates members of one set (the domain) with members of another set (the range): "A function is a relation so that no two distinct members have the same first coordinate" (p. 23). This definition is influenced by Bourbaki's (1939/1968) definition of the concept of function:

Let  $E$  and  $F$  be any two sets, which may or may not be distinct. A relation between a variable element  $x$  of  $E$  and a variable element  $y$  of  $F$  is called a

functional relation in  $y$  if, for all  $x \in E$ , there exists a unique  $y \in F$  which is in the given relation with  $x$ .

We give the name of function to the operation which in this way associates with every element  $x \in E$  the element  $y \in F$  which is in the given relation with  $x$ ;  $y$  is said to be the value of the function at the element  $x$ , and the function is said to be determined by the given relation. Two equivalent functional relations determine the same function. (Bourbaki, 1939/1968, p. 351)

According to Glenn James and Robert C. James (1992), “a sequence is a set of quantities ordered as are the positive integers” (p. 373). An infinite sequence, represented by  $\{a_1, a_2, a_3, \dots, a_n, \dots\}$ ,  $\{a_n\}_{n=1}^{\infty}$ , or  $(a_n)$ , is a function whose domain is the set of positive integers (James & James, 1992).

A shape pattern is a sequence of *geometric configurations* which develop in conformity with a fixed procedure. The geometric configurations are referred to as *elements* of the pattern. A shape pattern is imagined as continuing to infinity, and its regularity is referred to as its *invariant structure*. The building blocks of an element are referred to as *components*. The constituents of a shape pattern are illustrated in Figure 5.1. Each element of a shape pattern gives rise to a numerical value arising from the number of components within the element. In this way a sequence is said to be mapped from the shape pattern.

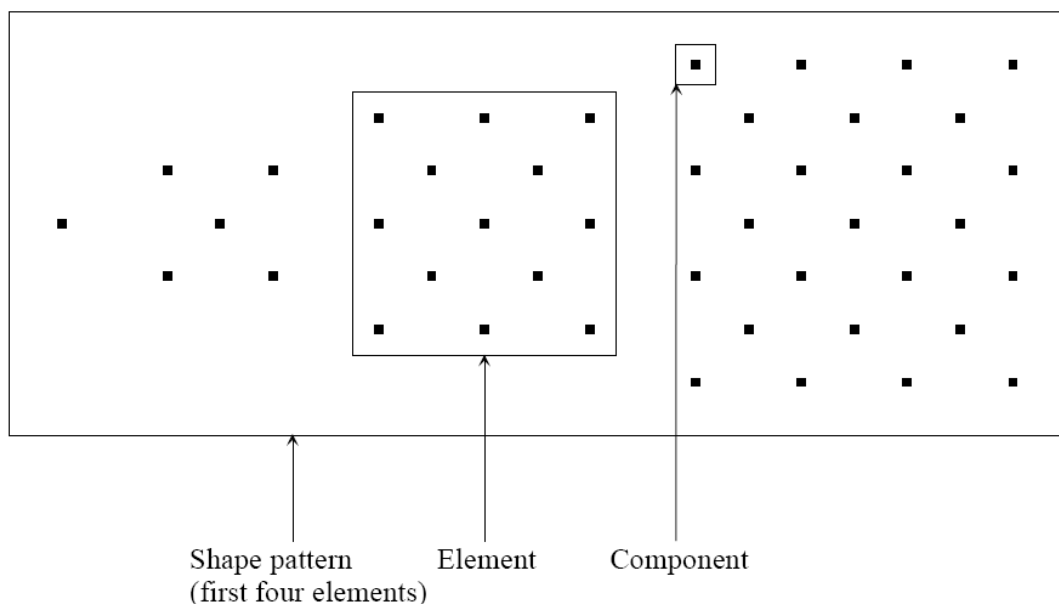

Figure 5.1. Constituents of (the first part of) a shape pattern

### 5.1.2 Arithmetic relations

The invariant structure of a shape pattern provides the possibility to *decompose* the elements into different repetitive parts (according to a fixed

procedure).<sup>75</sup> The point is to express the number of components of each partition as a function of the element's position in the shape pattern. The idea of decomposition is exemplified in Section 5.1.4 (Figure 5.4 and Figure 5.5). When numbers arising from partitions of an element are used in a mathematical expression, the result is an arithmetic expression<sup>76</sup> that represents the total number of components of the element. When an arithmetic expression is generalised (to represent the general member of the sequence mapped from the shape pattern) it turns into an algebraic expression where letters are placeholders for numbers.

Arithmetic expressions arising from elements of a shape pattern give rise to an *arithmetic relation* which is a set of ordered pairs. The first component of such an ordered pair represents the position of an element in the shape pattern. The second component is an arithmetic expression that represents the total number of components of the element and shows the relationship between the numbers representing the different partitions within the element.

The target mathematical knowledge in tasks on generalisation of shape patterns is the algebraic generalisation of arithmetic relations in members of the sequence mapped from the shape pattern. The point with introducing shape patterns into the teaching and learning of algebra is to offer a concrete reference context to facilitate algebraic thinking.

### 5.1.3 Generalisation in terms of two different types of mathematical objects

There are two types of shape patterns which can be classified according to the type of mathematical object their generalisation aims at. One type can be referred to as *arbitrary* shape patterns whose generalisation aims at a formula for the  $n$ -th member of the sequence mapped from the shape pattern. An example of such a pattern is given in Figure 5.2 (on the next page), where the generalisation can be symbolised algebraically as for instance  $f : n \rightarrow n^2 + (n - 1)^2$ , or  $f(n) = n^2 + (n - 1)^2$ .

The other type of shape patterns is *special* in the way that these patterns can be interpreted to represent number theoretical relationships

---

<sup>75</sup> “Decomposition” refers to diagrammatic isolation (encircling, painting with different colours, or other techniques) of various parts of the geometric configuration (element) in order to visualise the invariant structure of the shape pattern.

<sup>76</sup> An “arithmetic expression” is a composition of numbers and arithmetic operations (sum, difference, product, and quotient).

which have relevance beyond the context in which they are explored. That is, it is not only the sequence of numbers mapped from the elements of the shape pattern which is relevant in an algebraic generalisation process.

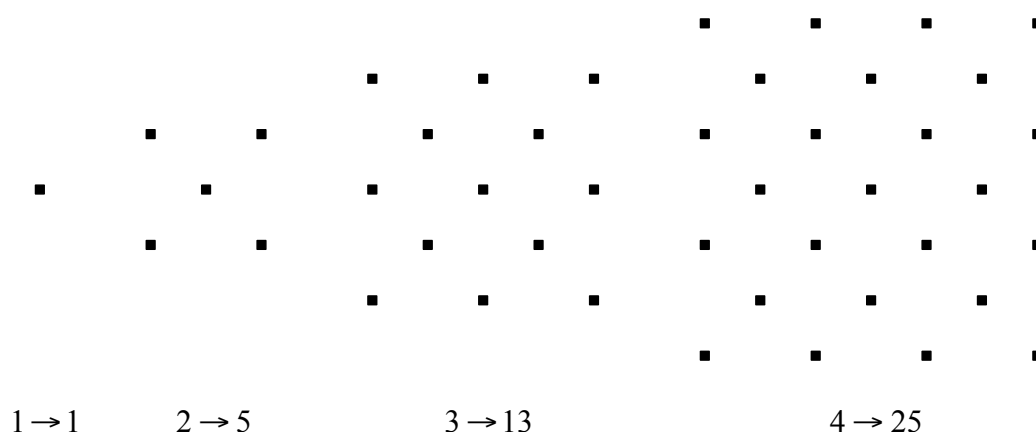

Figure 5.2. The first four elements of an arbitrary shape pattern whose generalisation is a formula for the  $n$ -th member in the sequence mapped from the pattern.

In these patterns the spatial properties of the elements is of importance; it is of significance how the elements are configured. This means that an element illustrates an equivalence relation between, on the one hand, an arithmetic expression mapped from partitions (collections of components) of an element, and, on the other hand, the total number of components of the element. An example is provided by the shape pattern presented in Figure 5.3, declared to illustrate a theoretical relationship between odd numbers and square numbers.

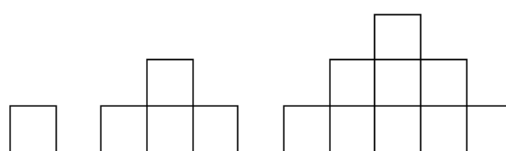

Figure 5.3. The first three elements of a shape pattern, intended to illustrate an equivalence relation between square numbers and sums of odd numbers.

This example is equal to the shape pattern in Task 3 with which the observed students engaged. The mathematical object aimed at is the mathematical statement,  $\sum_{i=1}^n (2i - 1) = n^2$ .

The relevant collections of components in the above example are the rows of the towers (where the components are single squares). Within an

element of this shape pattern, the point is to illustrate that the sum of the number of components of the rows (odd numbers) is equal to the total number of components of the element (a square number). These observations can be generalised in terms of an equivalence relation between the  $n$ -th square number and the sum of the first  $n$  odd numbers. This is a conjecture which asserts a mathematical relationship between members of sets of numbers.<sup>77</sup> It has relevance beyond the shape pattern in which it is discovered.

I will explain the nature of the different mathematical objects (formula for  $n$ -th member of sequence, and mathematical statement about relationships between sets of numbers) in Section 5.1.4 and Section 5.1.5, respectively.

#### 5.1.4 Formulae for the general member of a sequence

There are two different approaches to obtain the general member of a sequence. One is a *recursive approach* which focuses on arithmetic relationships between a member and its predecessor(s) in the sequence; how the current member is developed from the previous one(s). A recursive approach results in a recursive formula, for example  $u_{n+1} = f(u_n)$ . The other is an *explicit approach* which focuses on a functional relationship between the position of a member in the sequence and the member itself. An explicit approach results in an explicit formula, for example  $u_n = f(n)$ .

A *recursive formula* for the general member,  $a_n$ , of a sequence is a mathematical relationship, a recurrence relation, expressing  $a_n$  as some combination of  $a_i$  with  $i < n$ . When formulated as an equation to be solved, recurrence relations are known as recurrence equations, or difference equations (Weisstein, 2009, Vol. 3, p. 3301). A *linear* recurrence equation is a recurrence equation on a sequence of numbers  $\{a_n\}_{n=1}^{\infty}$  expressing  $a_n$  as a first-degree polynomial in  $a_k$  with  $k < n$  (Weisstein, 2009, Vol. 2, p. 2322). An example can be given by the recurrence equation  $a_n = a_{n-1} + a_{n-2}$  with initial conditions,  $a_1 = a_2 = 1$ . The outcome of this recurrence equation is known as the *Fibonacci numbers*.

---

<sup>77</sup> In order for the conjecture to be established as a *theorem*, it needs to be proved. This feature will be explained in Section 5.1.5.

Members of the sequences mapped from the shape patterns in the tasks with which the observed students engaged satisfy the linear recurrence equation,  $a_n = a_{n-1} + d(n-1)$  with some initial condition,  $a_1 = k$  with  $k$  a constant, and  $d(i)$  an integer function which denotes the *difference* function between  $a_{i+1}$  and  $a_i$ . The properties of the function  $d$  determine the type of *growth* of the sequence, a concept which will be explained in Section 5.1.6.

Figure 5.4 shows how the second, third, and fourth elements of the arbitrary shape pattern (presented in Figure 5.2 above) are decomposed into the respective previous element plus a multiple of four. The recursive formula for the  $n$ -th member of the sequence mapped from this pattern is given by  $a_n = a_{n-1} + 4(n-1)$  with initial condition,  $a_1 = 1$ . It is observed that the difference function in this example is given by  $d(i) = 4i$  for  $i \in \bullet$ .

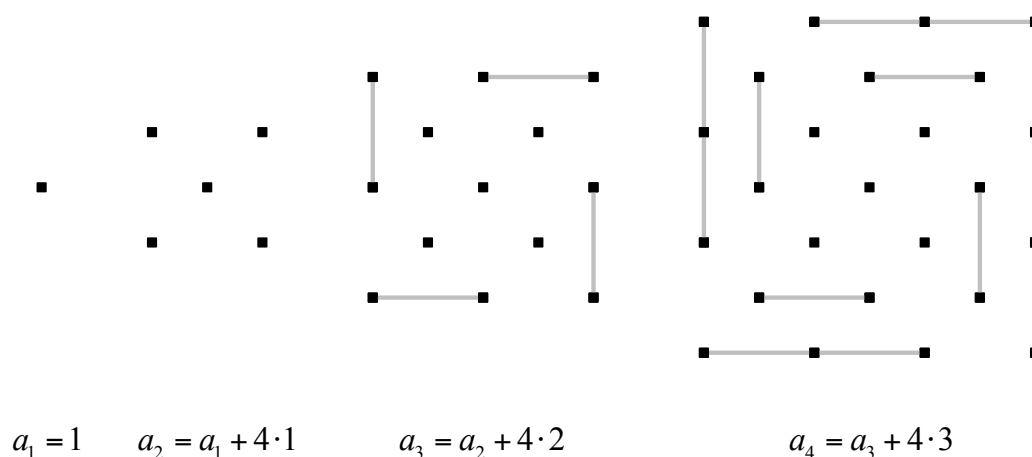

Figure 5.4. The first four elements of a shape pattern illustrating that the first three differences are multiples of four

An *explicit formula* for the general member of a sequence can be given in terms is a *functional relationship* (Bourbaki, 1939/1968) between the position of the member in the sequence and the member itself. That is, an explicit formula expresses the general member as a function of  $n$ . As explained in Section 5.1.2, elements of a shape pattern can be decomposed into repetitive parts that correspond to the invariant structure of the pattern. This results in arithmetic expressions that show the functional relationship between position and number of components of the repetitive parts of the elements. Further, one of the elements (together with the arithmetic expression that represents its number of components) can be used as a generic example to establish an algebraic generalisation



in terms of an explicit formula for the  $n$ -th member of the sequence mapped from the shape pattern.

The elements of the arbitrary shape pattern presented in Figure 5.2 above can be decomposed into two consecutive squares as shown in Figure 5.5. The third or fourth of the decomposed elements can be used as a generic example to establish that the functional relationship between  $n$  (position) and the general member of the sequence mapped from the shape pattern (in Figure 5.2 above) is given by  $f(n) = n^2 + (n - 1)^2$ .

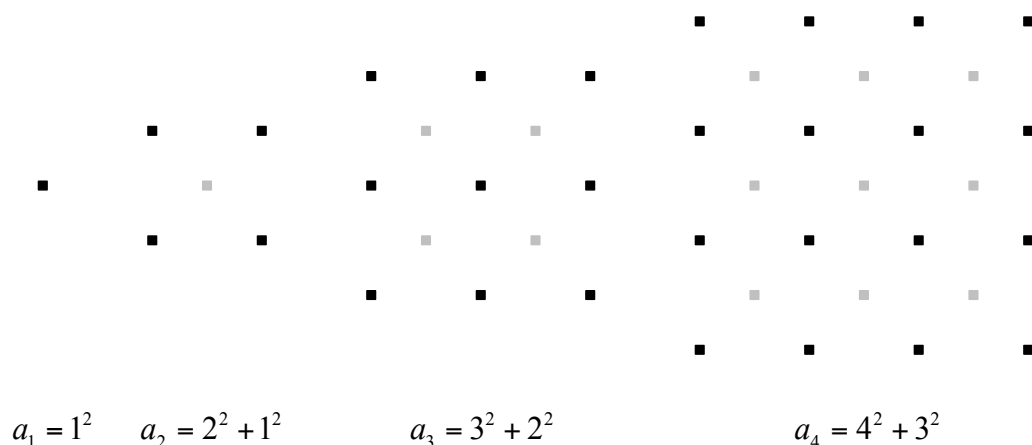

Figure 5.5. A possible decomposition of elements of a shape pattern illustrating nested squares

Another approach to the explicit formula can be done by the decomposition presented in Figure 5.4 above which stimulates the expression

$$g(n) = 1 + \sum_{i=1}^{n-1} 4i.$$

A closer examination will be made of these formulae (the functions  $f$  and  $g$ ) in Section 5.2.2.

The two different approaches (explicit and recursive) to the general member of a sequence mapped from a shape pattern will be explained in more detail in Section 5.2, where I present the didactical analysis of the mathematics potential in tasks on algebraic generalisation of shape pattern.

### 5.1.5 Mathematical statements

According to Timothy Gowers (2008), mathematical statements are the object of research papers in mathematics and the main currency of the discipline. Different types of mathematical statements include *theorems*, *propositions*, *lemmas*, and *corollaries*, the common feature of which is that their truth is established by means of a mathematical proof (Gowers, 2008).

A theorem is “a statement that has been proved to be true if certain hypotheses (axioms) are true” (James & James, 1992, p. 419). A proof of a theorem may use previously proved theorems instead of making explicit use of the hypotheses (James & James, 1992). Whereas theorems are regarded to be intrinsically interesting, propositions are more predictable results which are easier to prove (Gowers, 2008). It is common to define a statement that follows “easily” from a theorem as a *corollary* to that theorem, whereas a statement that is proved primarily because of its use in proving another theorem is said to be a *lemma* (James & James, 1992).

According to James and James (1992), a *principle* is a general truth or law, either assumed or proved to be true. If a principle is assumed true, it is called a postulate or axiom; if a principle is or is to be proved, it is called a theorem (James & James, 1992). A *formula* is a general answer, rule, or principle which is expressed in terms of mathematical symbols (James & James, 1992). Formulae can be given for instance by equations, equalities, identities, inequalities, and limits (Weisstein, 2009, Vol. 1, p. 1412). An equality is a mathematical statement of the *equivalence* of two quantities. The above given definitions of the concepts of mathematical statement and formula require that a formula is a mathematical statement only in the case where it is a principle which is to be proved (i.e., it is a theorem).

Like a formula for the  $n$ -th member of a sequence (generalisation of a quantity) can be approached in two ways, a mathematical statement about number theoretical relationships can also be approached in two ways: by a recursive or by an explicit approach. A mathematical relationship between square numbers and odd numbers can, as mentioned in Section 5.1.3, be given explicitly (i.e., in closed form) in terms of an equivalence relation between the  $n$ -th square numbers and the sum of the first  $n$  odd numbers (a statement about how square numbers are constructed from odd numbers). Also, a mathematical relationship between square numbers and odd numbers may be given recursively as an equivalence relation between the  $n$ -th square number and the sum of the  $(n - 1)$ -th square number and the  $n$ -th odd number (a statement about how the square numbers are constructed from a square number and an odd number).

### 5.1.6 Growth of sequences

The sequences mapped from the shape patterns in the tasks with which the observed students engaged are recursive sequences. Their general member is given by  $a_n = a_1 + d(1) + d(2) + d(3) + \dots + d(n - 1)$  with  $d(i)$  an integer function which denotes the difference function between  $a_{i+1}$  and  $a_i$ . If a sequence has the property that for all  $i < n$ ,  $d(i) = b$  with  $b$  a

constant, the growth of the sequence is characterised as *linear* (or *arithmetic*, according to Kalman, 1997). That is, each member of the sequence is computed from the previous member by adding a constant  $b$ . The general member of a sequence with linear growth is then given by:

$$a_n = a_{n-1} + b = a_{n-2} + 2b = a_{n-3} + 3b = \dots = a_1 + b(n-1), \text{ with } n > 1.$$

A sequence with this property is denoted an *arithmetic* sequence and  $b$  is referred to as its *difference*<sup>78</sup> (James & James, 1992).

If a sequence has the property that for all  $i < n$ ,  $d(i) = bi + c$  with  $b \neq 0$  and  $c$  constants, the growth is characterised as *quadratic*. That is, each member of the sequence is computed from the previous member by adding a number which is a linear function of the element's position. The general member of a sequence with quadratic growth is then given by:

$$\begin{aligned} a_n &= a_{n-1} + b(n-1) + c = a_{n-2} + b(n-2) + c + b(n-1) + c \\ &= \dots = a_1 + b + c + a_2 + 2b + c + \dots + a_{n-1} + b(n-1) + c \\ &= a_1 + (n-1)c + b(1+2+3+\dots+n-1) \\ &= \frac{b}{2}n^2 + (c - \frac{b}{2})n + a_1 - c, \text{ with } n > 1. \end{aligned}$$

The above explication shows how knowledge of growth of sequences can be used to make links between recursive and explicit formulae; that is, how an explicit formula for the general member can be developed from a recursive formula.

## 5.2 Didactical analysis

In Sections 5.2.1, 5.2.2, and 5.2.3 I present the potential of mathematical tasks based on shape patterns as a means of stimulating students' engagement with algebraic generalisation and its implications of establishing formulae or mathematical statements.

### 5.2.1 Different approaches to and different modes of reasoning about algebraic generality in shape patterns

In this section I present different approaches to and different modes of reasoning about algebraic generality in shape patterns. Categorisation of

<sup>78</sup> The sum of an arithmetic sequence  $\{a_i\}_{i=1}^{\infty}$  is termed an *arithmetic series* (Weisstein, 2009, Vol. 1, p. 168). The  $n$ -th partial sum  $S_n$  of an arithmetic series is therefore given by

$$S_n = a_1 + (a_1 + b) + (a_1 + 2b) + \dots + a_1 + (n-1)b = na_1 + \frac{1}{2}bn(n-1) = \frac{1}{2}n[2a_1 + b(n-1)].$$

approaches to generality of shape patterns into recursive and explicit approaches, as introduced in Section 5.1.4, is based on the way one proceeds to find a representation of generality; that is, whether one aims at a relationship between elements of the pattern, or, at a relationship between position and element.<sup>79</sup> The syntax of the resulting generality is different in the two cases (recursive or explicit formula for the  $n$ -th member of the sequence mapped from the shape pattern, or a recursively or explicitly expressed mathematical statement about a number theoretical relationship illustrated by the shape pattern). Each of these ways of approaching generality can, further, be categorised into either a *figural* or *numerical* mode of reasoning.<sup>80</sup>

#### *Figural mode of reasoning*

By a figural mode of reasoning I mean reasoning that is based on structural relationships in the geometric configurations, either between position and element (aiming at an explicit formula or a mathematical statement), or, between consecutive<sup>81</sup> elements (aiming at a recursive formula or a recursively defined mathematical statement). A figural mode of reasoning is based on decomposition of the elements of the shape pattern. By this is meant diagrammatic isolation (e.g., encircling, painting with different colours as used in Figure 5.4 and Figure 5.5, or other techniques<sup>82</sup>) of various parts of the geometric configurations according to a procedure determined by the invariant structure of the pattern. To make the presentation more lucid, I will in the rest of the explication of the figural mode refer only to the case when the generality aimed at is an

---

<sup>79</sup> Recall that the notion of “element” refers to the geometric configurations which constitute the shape pattern. Hence, the approaches referred to include both the case when the mathematical object aimed at is a formula for the  $n$ -th member of a sequence and the case when the mathematical object aimed at is a number theoretical relationship.

<sup>80</sup> The reader who is familiar with Joanne R. Becker and Ferdinand Rivera’s work will notice that the categories “figural” and “numerical” that I am using are not the same as those used by Becker and Rivera (2005, 2006) in the notions, “figural generaliser” and “numerical generaliser”. Whereas employing a figural mode of reasoning is consistent with being a figural generaliser, employing a numerical mode of reasoning is not consistent with being a numerical generaliser.

<sup>81</sup> Recall from Section 5.1.4 that members of the sequences mapped from the shape patterns in the actual tasks satisfy the linear recurrence equation,  $a_n = a_{n-1} + d(n-1)$  with some initial condition,  $a_1 = k$  with  $k$  a constant, and  $d(i)$  an integer function which denotes the *difference* function between  $a_{i+1}$  and  $a_i$ . Hence, it is a recursive approach that focuses on a relation between *consecutive* elements.

<sup>82</sup> Decompositions may be done mentally.

explicit formula for the  $n$ -th member of the sequence arising from the shape pattern.<sup>83</sup>

As explained in Section 5.1.4, an explicit formula expresses the general member of the sequence mapped from the shape pattern as a function of  $n$ . The essence of the figural mode is that the numerical values of the repetitive parts resulting from the decomposition of an element are expressed as a function of the position of the element in the pattern. When the numerical values of the partitions of an element are written as a sum, the result is an arithmetic expression of the numerical value of the element itself. This stage in the figural mode I refer to as the *arithmetic-structural level*. Further, the arithmetic expression of one of the elements is used as a generic example to express the  $n$ -th member of the sequence in algebraic symbols (as a function of  $n$ ).

The figural mode of reasoning as described above is relation-oriented in the sense that one tries to identify an invariant structure in the alignment of elements of the shape pattern. Hence, the figural mode of reasoning is based on algebraic thinking, as defined in Section 3.3.2 with reference to Mason (1996).

#### *Numerical mode of reasoning*

By a numerical mode of reasoning I mean reasoning that is based on numbers. These numbers are members of the sequence mapped from the shape pattern. The numerical mode can be used both in an explicit approach (searching for a relationship between position and member) and in a recursive approach (searching for a relationship between consecutive members). To make the presentation more lucid, I will in the rest of the explication of the numerical mode refer only to the case when the generality aimed at is an explicit formula for the  $n$ -th member of the sequence arising from the shape pattern.

The numerical mode of reasoning can be further classified into two subcategories; one involves reasoning at the *arithmetic-structural* level as described for the figural mode; the other involves a method of *guess-and-check* to find the formula which represents the generality in the

---

<sup>83</sup> A figural mode when the aim is a mathematical statement about number theoretical relationships is similar to the case when the aim is a formula for the  $n$ -th member of the sequence. The essence of a figural mode of reasoning when the aim is a recursive formula or a recursively defined mathematical statement, however, is to express the  $n$ -th first difference as a function of its position (instead of expressing the general member itself as a function of its position).

shape pattern. The arithmetic-structural level involves identification and generalisation of arithmetic relationships between numbers (as explained for the figural mode). Because the mathematical object aimed at is an explicit formula, these relationships are between positive integers (representing positions of members in the sequence) and the members themselves. The method of guess-and-check involves starting with the first few members of the sequence mapped from the shape pattern and employing naïve empiricism (see Section 3.2) to establish a formula for the generality.

Whereas the arithmetic-structural level is based on algebraic thinking as accounted for above, the method of guess-and-check short-circuits all the richness of the generalisation process because the students remain unaware of the nature of the generality they represent (Mason, 1996; see also, Orton & Orton, 1999). The different paths towards generality in shape patterns are illustrated in Figure 5.6.

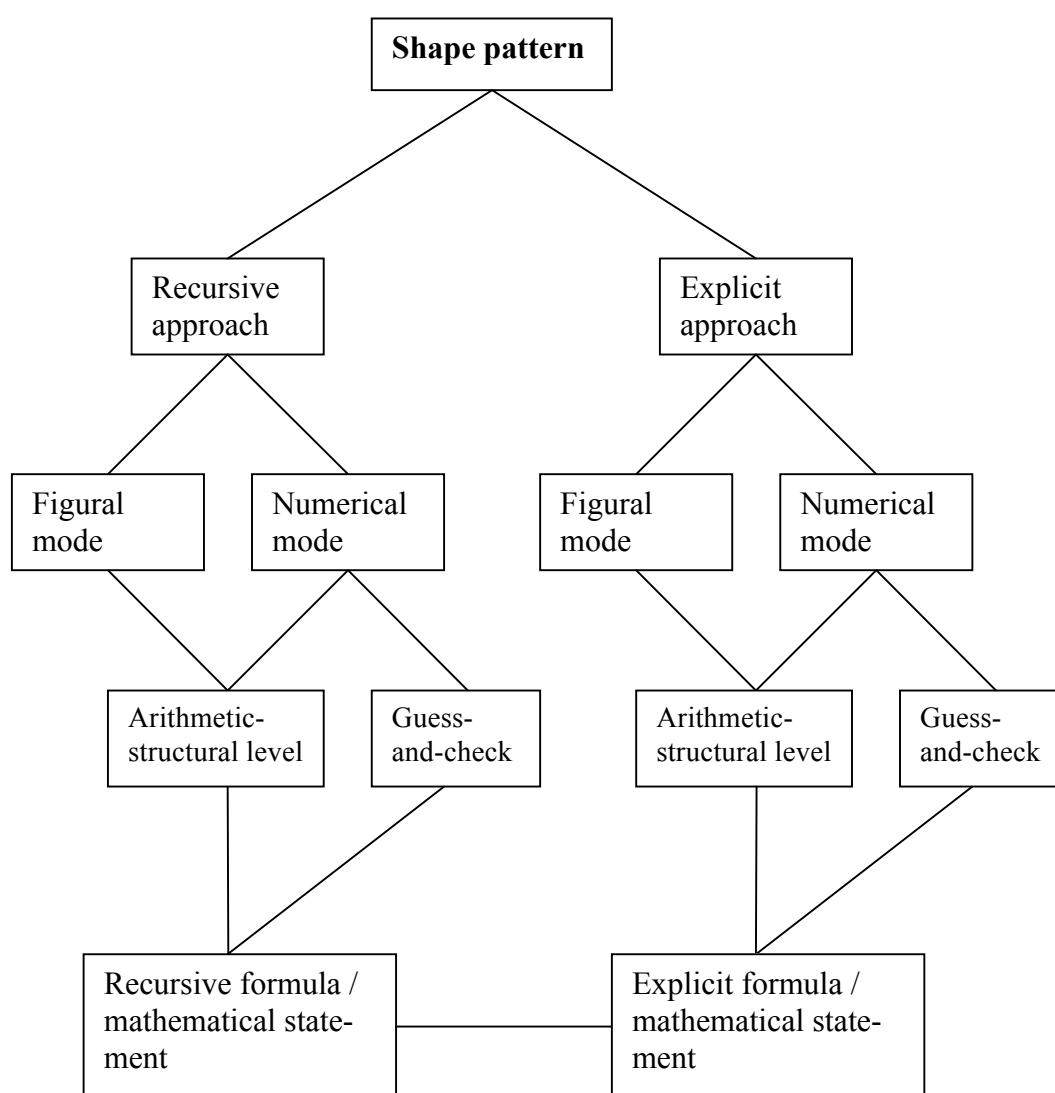

Figure 5.6. Different approaches to generality in shape patterns

A demonstration of the figural and numerical modes of reasoning based on a particular shape pattern is provided in the next section.

### 5.2.2 Exemplification of different modes of reasoning towards an explicit formula for the $n$ -th member of a sequence mapped from a shape pattern

The algebraic generalisation I will exemplify in this section is an explicit formula for the  $n$ -th member of the sequence mapped from the “dots-at-grid” pattern presented in Figure 5.7 (this pattern was first presented in Figure 5.2 above but is reproduced here for the sake of continuity).

#### *Figural mode of reasoning exemplified*

The invariant structure of the “dots-at-grid” pattern (Figure 5.7) can be illustrated by various decompositions, two of which were presented in Section 5.1.4 (Figure 5.4 and Figure 5.5).

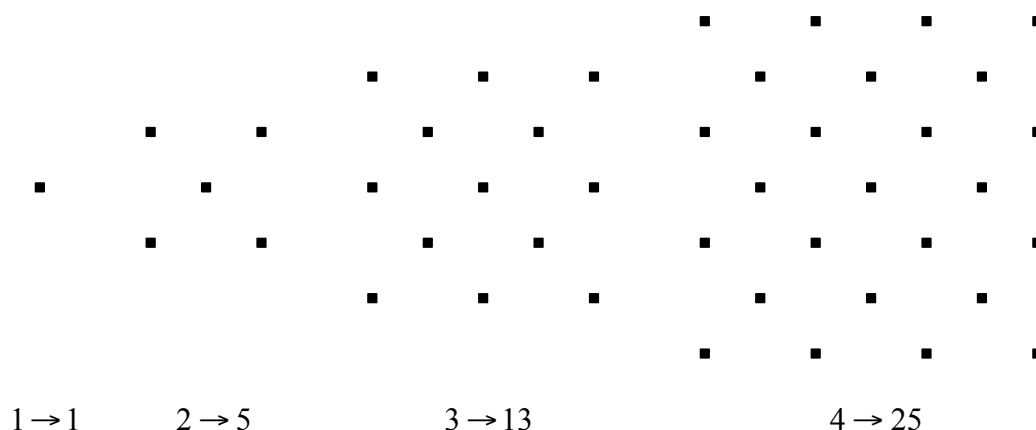

Figure 5.7. The first four elements of an arbitrary shape pattern whose generalisation is a formula for the  $n$ -th member in the sequence mapped from the pattern.

A first decomposition, shown in Figure 5.5 (Section 5.1.4), illustrates partitions in terms of nested squares. At the arithmetic-structural level this structure can be represented by expressions as listed in Table 5.1.

**Table 5.1. Arithmetic expressions originating from a decomposition in terms of two squares, generalised algebraically**

Position	1	2	3	4	L	$n$
Number of dots	$1^2 + 0^2$	$2^2 + 1^2$	$3^2 + 2^2$	$4^2 + 3^2$	L	$n^2 + (n-1)^2$

In the  $n$ -th position of this table the arithmetic expression is generalised to show the functional relationship between position and member of the sequence mapped from the shape pattern in Figure 5.7 above. Hence, the

decomposition that illustrates nested squares is generalised algebraically in terms of the function,  $f(n) = n^2 + (n - 1)^2$ .

A second decomposition of the “dots-at-grid” pattern, shown in Figure 5.4 above illustrates partitions in terms of multiples of four. At the arithmetic-structural level this structure can be represented by expressions as listed in Table 5.2.

**Table 5.2. Arithmetic expressions originating from a decomposition in terms of multiples of four, generalised algebraically**

Position	1	2	3	L	$n$
Number of dots	1	$1 + 4 \cdot 1$	$1 + 4 \cdot 1 + 4 \cdot 2$	L	$1 + \sum_{i=1}^{n-1} 4i$

In the  $n$ -th position of this table the arithmetic expression is generalised to show the functional relationship between position and member of the sequence mapped from the shape pattern in Figure 5.7 above. Hence, the decomposition that illustrates multiples of four is generalised

algebraically in terms of the function,  $g(n) = 1 + \sum_{i=1}^{n-1} 4i$ . This is one more

than the  $n$ -th partial sum of an arithmetic series with difference four. The  $n$ -th partial sum of an arithmetic series implies that

$g(n) = 1 + 4 \frac{n}{2}(n - 1) = 2n^2 - 2n + 1 = f(n)$ , where  $f$  is the function originating from the decomposition that illustrates nested squares (presented in Figure 5.5 above).

Representation of the explicit formula in terms of the series given by the function  $g$  also shows a relationship between a recursive and an explicit formula for the generality in the sequence mapped from the shape pattern. It shows how an explicit formula can be developed by starting with the first member and adding successively the first differences of the sequence mapped from the shape pattern. As presented in Chapter 3, Lannin et al. (2006) argue that it is important for students to connect recursive and explicit formulae as a potential means for constructing successful generalisations in terms of explicit formulae.

*Numerical mode of reasoning exemplified*

A numerical mode of reasoning about generality in the shape pattern presented in Figure 5.2 takes as a starting point the numbers in the sequence  $\{1, 5, 13, 25, 41, L\}$  which correspond to the numerical values of the elements of the shape pattern. It can be observed that the members in this sequence, except for the first member, are one more than particular numbers in the four-times table. Hence, the sequence can be written,



$\{1, 1 + 4 \cdot 1, 1 + 4 \cdot 3, 1 + 4 \cdot 6, 1 + 4 \cdot 10, L\}$ . This is reasoning at the arithmetic-structural level, and is the basis for generalisation by using algebraic thinking: A systematic way to write the members of the sequence is  $\left\{1, 1 + 4 \cdot 1, 1 + 4 \cdot (1 + 2), 1 + 4 \cdot (1 + 2 + 3), L, 1 + 4 \sum_{i=1}^{n-1} i, L\right\}$ . It is observed that the factors by which four is multiplied are sums of consecutive natural numbers (i.e., they are triangular numbers). The explicit formula for the  $n$ -th member of the sequence is given by the  $n$ -th partial sum of the series  $g(n) = 1 + \sum_{i=1}^{n-1} 4i$  which was shown to be equal to  $f(n) = n^2 + (n - 1)^2$ .

The alternative path in a numerical mode of reasoning is the method of guess-and-check, which involves that the numbers in the sequence  $\{1, 5, 13, 25, 41, L\}$  are used to guess a formula which is checked against a few members in the sequence. Lannin et al. (2006) recommend that mathematical tasks aiming at algebraic generalisation of shape patterns are designed so as to promote students to remain connected to the iconic representations and avoid the desire to apply a strategy of guess-and-check. This is important in order to avoid students remaining unaware of the nature of the generality they are supposed to represent algebraically (Mason, 1996). In the concrete example, there is little value, with respect to mathematical learning, in students' development of a formula like  $f(n) = 2n^2 - 2n + 1$  if students do not appropriate an understanding of how the formula is related to the shape pattern from which it originates.

### 5.2.3 The value of algebraic generalisation of shape patterns with respect to mathematical learning

There is a two-fold purpose of students' engagement with algebraic generalisation of shape patterns; these can actually be considered two sides of the same coin. One is to provide a context (physical or iconic) for algebraic generalisation where the aim is to promote students' algebraic thinking. This can be considered as an approach to algebra through pattern generalisation. The other is to lead students to experience patterns as mathematical structures as an aim in itself, where infinity and generalisation are focused upon. In this perspective, algebra is a mediational means to represent invariant structures in the patterns.

In both perspectives (algebra manifested in patterns, or patterns generalised through algebra), the mathematical concepts introduced in Section 5.1 are central. Another aspect that I want to stress is *justification* of the conjectured formulae or mathematical statements. A goal in general-

ising shape patterns is to obtain a new result; a formula for the general member of a sequence arising from the pattern, or a mathematical statement about number theoretical relationships arising from the pattern. As explained in Section 3.2, with reference to Radford (1996), generalisation in this sense is not a concept, but a procedure based on the observed facts, allowing the generation of a new result. The logical base underlying such a procedure is that of justification of the new result. According to Radford, it is a proof process, which moves from empirical knowledge (related to the observed number facts in a sequence of geometrical configurations) to abstract knowledge that is beyond the empirical scope. Central in justifying the conjectured generality through a figural mode is the utilisation of a *generic example* as explained in Section 3.2. Balacheff (1988) explains why the generic example, despite being pragmatic, is a valid proof (see Section 3.2). For further details about the milieu for generalisation and the different roles of the student and the teacher in the didactical situation, I refer to the explication in Section 2.3.4.

#### *Different nature of the target knowledge*

The nature of a formula for the general member of a sequence mapped from a shape pattern is different from the nature of a *mathematical statement* about number theoretical relationships arising from the shape pattern. The first mathematical object, a formula, is inevitably connected to the presented shape pattern. The second mathematical object, a mathematical statement, is, on the other hand, decontextualisable in the sense that it has relevance beyond the shape pattern from which it originates.

Institutionalisation of the knowledge in the case when algebraic generalisation aims at a formula is not institutionalisation of the formula per se. It is institutionalisation of how the formula can be derived through identification of an invariant structure in the elements of the pattern. Further, it is institutionalisation of how the invariant structure is interpreted into arithmetic relations and how these in turn are generalised algebraically in terms of a formula (for the general member). The cultural, reusable knowledge in this case is the nature of the relationship between the algebraic expression and its referent (a generic element of the pattern). On the other hand, institutionalisation of the knowledge in the case when algebraic generalisation aims at a mathematical statement involves decontextualisation of the mathematical statement from the shape pattern on the basis of which it is developed. The cultural, reusable knowledge in this case is algebraic generalisation of arithmetic relations between sequences of numbers. Either generality aims at a formula or a mathematical statement, the target knowledge involves students' understanding of generality, proof, and so forth.

As described in Section 5.1.3, there are two different types of shape patterns which correspond to the two types of mathematical objects aimed at when generalising shape patterns; formulae or mathematical statements. The foregoing didactical analysis reveals the potential of tasks based on shape patterns as a means of stimulating students' engagement with algebraic generalisation and its entailments of formulating propositions, theorems, and proving. However, a didactical analysis does not presume that the mathematical aims will be met. The challenge that faces mathematics teachers at all levels is to design tasks that enable students to experience the intended mathematical challenge and appropriate the desired mathematical knowledge.

In the next three chapters I present the analytic categories that emerged from the exploration of the empirical material. These chapters are introduced by a prelude to the analysis.

## Prelude to the analysis

In the next three chapters I present the results from the analysis. It is organised by the three analytic categories that emerged from exploration of the empirical material.

Chapter 6 presents the first analytic category. It is about features of the didactical milieu. Situations of action, formulation, and validation are (intentionally) didactical situations where each situation has a feedback potential on which the success of the situation depends. The category deals with how the didactical milieu is constrained in the way that it does not provide the students with adequate feedback which could tell them if their responses are appropriate. The first category is organised around three properties of the milieu: adaptedness of design of tasks; clarity of concepts; and, outcome of institutionalisation of previous knowledge.

Chapter 7 presents the second analytic category. It is about features of the situation of formulation of algebraic generality in shape patterns. The category deals with challenges the students face when they shall transform into algebraic notation formulae and mathematical statements they have expressed informally in natural language. These challenges are divided into two different categories: recursive and explicit approaches to generality; and, engagement with the syntax of algebra.

Chapter 8 presents the third analytic category. It is about features of the situation of validation. The category deals with challenges related to students' justification of algebraic generality in shape patterns. These challenges are divided into two different categories: pertinence of concepts (spontaneous versus scientific concepts); and, validity of reasoning (empirical reasoning versus formal, mathematical reasoning).

In the next chapter I present the first analytic category. It is referred to as *Constrained feedback potential in didactical situations*.

## 6 Constrained feedback potential in *adidactical* situations

In this chapter I present one of the analytic categories that emerged from the exploration of data from student teachers' collaborative work on algebraic generalisation of shape patterns. I analysed the data with the purpose of answering the research question presented in Chapter 4: "What factors constrain students' appropriation of algebraic generality in shape patterns?" The analysis draws on the epistemological and didactical analyses of the mathematics potential in the tasks presented in Chapter 5. The analytic category is called *Constrained feedback potential in adidactical situations*.

I show how the feedback potential in adidactical situations is constrained by these features: by the design of the tasks (Section 6.1); by the students' unfamiliarity with the concept of a mathematical statement, and by the teacher's use of a generic example without the students' awareness of it (Section 6.2); and, by incomplete institutionalisation of previous knowledge (Section 6.3). Next, a summary of the findings is presented (Section 6.4). The chapter closes with a discussion of how the identified constraints constitute shortcomings in the milieu for algebraic generalisation of shape patterns (Section 6.5).

Notes from conversations I had with teacher Erik were written in my research journal on the same day the conversations took place. These notes will be referred to by RJ\_dd.mm.year.

### 6.1 Features of the objective milieu arising from the design of the tasks

In this section I present the first subcategory of *Constrained feedback potential in adidactical situations*. The phenomenon described by this subcategory is manifested in two circumstances: in how students' adequate solutions to subtasks fail to prepare a *milieu* for appropriation of the target mathematical knowledge; and, in how the idea of proof as intended by the teacher is not apparent to the students.

#### 6.1.1 Adequate solutions to subtasks do not prepare an adequate milieu for the (teacher's) intended mathematical statement

According to the epistemological analysis presented in Section 5.1.3, the target mathematical knowledge in Task 3 (Figure 6.1 on the next page) is a theorem about equivalence of two expressions. More explicitly, the target knowledge is algebraic generalisation of equivalence relations between square numbers and sums of odd numbers. Teacher Erik who has designed the tasks claimed that the goal of Task 3 was for the students to

express in natural language, and transform into algebraic notation, the mathematical statement that the sum of the first  $n$  odd numbers is equal to the  $n$ -th square number (RJ\_06.02.2004).

Task 3 (Part I)

Look at the shapes below.<sup>84</sup> You may use centicubes to concretise.

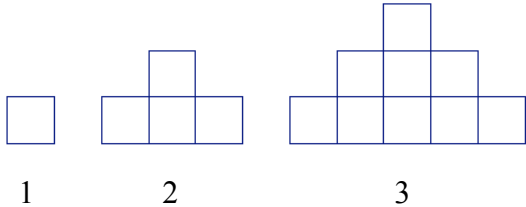

1                      2                      3

- How many cubes will there be in the fourth shape? And in the fifth?
- How many do you think there will be in shape number 10? And in shape number  $n$ ?
- What kinds of numbers are present in these shapes? In each row, and totally in the shape?
- Can you express what the shapes seem to show, as a mathematical statement?<sup>85</sup>
  - In words?
  - In symbols?

Figure 6.1. Task 3 (Part I)

Both Group 1 and Group 2 answer Task 3a by counting components of the first few elements of the shape pattern and noticing that the numerical value of an element is equal to the square of the element's position. Based on this observation, the students conjecture by naïve empiricism ("guess-and-check") that the tenth shape has 100 components and that the  $n$ -th element has  $n^2$  components. Students of both groups answer correctly the next question about what types of numbers there are in the rows and totally in the elements of the shape pattern (that it is odd

<sup>84</sup> The notion "shape" (in Norwegian, "figur") is used in the mathematical tasks and by the observed students and teachers to refer to an element of a shape pattern. I will however use the notion "element" (as introduced in Chapter 5) in the report, but use the notion "shape" when I quote from tasks and participants' speech.

<sup>85</sup> "Mathematical statement" has been translated into English from the Norwegian expression "matematisk setning" which is used in Task 3 and Task 4.

numbers and square numbers, respectively). Both groups' solution to the question about "a mathematical statement that expresses what the elements seem to show" is given in terms of a formula that expresses that the  $n$ -th element has  $n^2$  components. It is symbolised as  $F_n = n^2$  by students of Group 1,<sup>86</sup> and symbolised as  $a_n = n^2$  by students of Group 2.

There is no feedback potential in the situation of action related to arithmetic relations between odd numbers and square numbers (the concept at stake). The students act as practical persons in accordance with the principle of economy of logic (Bourdieu, 1980, as cited in Balacheff, 1991) and produce solutions to Tasks 3a, 3b, and 3c in a most efficient way. This means that they count the components and reason by naïve empiricism to find the answer for the tenth and  $n$ -th element. In doing this they do not focus on the structure of the elements (that the total number of components of an element is equal to the sum of the components in each row).

Considered separately, the students' solutions are adequate. However, their solution to the question about the types of numbers in rows and elements as a whole (presumably meant to draw attention to the concept aimed at) does not provide them with the possibility to adjust their actions towards the formulation of a mathematical statement about a relationship between odd numbers and square numbers. The only way their knowing the answer to this question might have contributed to the formulation of a mathematical statement, would have been if they had tried to figure out the teacher's intention with the task. But that would have been a solution by didactical reasoning, and consequently, a threat to the adidactical situation. Hence, the problem is not the students' existing knowledge. There is a problem with the design of the adidactical situation; the design of Task 3 does not provide the students with knowings that enable them to formulate a mathematical statement, and, consequently, appropriate the target mathematical knowledge. The lack of focus on the target mathematical knowledge (arithmetic relations between odd numbers and square numbers) makes the objective milieu inappropriate.

---

<sup>86</sup> For Group 1,  $F_n$  stands for "the  $n$ -th shape" (or, figure number  $n$ ; in Norwegian the students say "figur nummer  $n$ "). It represents the  $n$ -th member of the sequence mapped from the shape pattern. Standard mathematical notation (with  $F$ ) would be  $F_n$  or  $F(n)$ .

In the next section I present the second manifestation of *Features of the objective milieu arising from the design of the tasks*.

### 6.1.2 The idea of proof as intended in Task 3 is not apparent for the students

Teacher Erik has designed Part I of Task 3 with the purpose of the students' conjecturing the mathematical statement of an equivalence relation:  $1 + 3 + 5 + \dots + 2n - 1 = n^2$ . Part II of Task 3 (reproduced in Figure 6.2) is designed to motivate the proof of the mathematical statement from Part I.

Task 3 (Part II)

The mathematical statement that you have formulated above is only based on a few observations. It is therefore just a conjecture. In order for it to become a justified statement, it needs to be proved. We will now look at a possible way to do this.

Below, the staircase towers have been extended into rectangles.

e) Build or draw (using two colours or symbols) the next shape in this pattern.

f) Find an explicit formula for the total number of squares in the  $n$ -th shape. Then find an explicit formula for the number of  $\square$  in the  $n$ -th shape.

g) Use this to find the number of  $\blacksquare$  in shape number  $n$ .

h) Discuss if the conjecture from earlier in the task can be considered proved now.

i) An alternative way to prove it may be through a so-called proof by induction (see last page). Those who want to go a bit further here can try that!

Figure 6.2. Task 3 (Part II)

Figure 6.3 (on the next page) shows the connection between Part I and Part II of Task 3 as intended by the teacher to prove the mathematical statement aimed at. According to a conversation with teacher Erik after the observed lessons on 6 February, 2004 (RJ\_06.02.2004), the intention with Part II of Task 3 is that the students utilise structure (area of rectangle with width  $n$  and length  $2n - 1$ ) to express the total number of components of the  $n$ -th rectangle by the product,  $n \cdot (2n - 1)$ . This expression will be referred to as Formula 1. Further, the teacher's intention is that the students utilise prior knowledge of triangular numbers to express the



number of white squares in the  $n$ -th rectangle by  $2 \cdot \frac{(n-1)n}{2} = n^2 - n$ . This expression will be referred to as Formula 2.

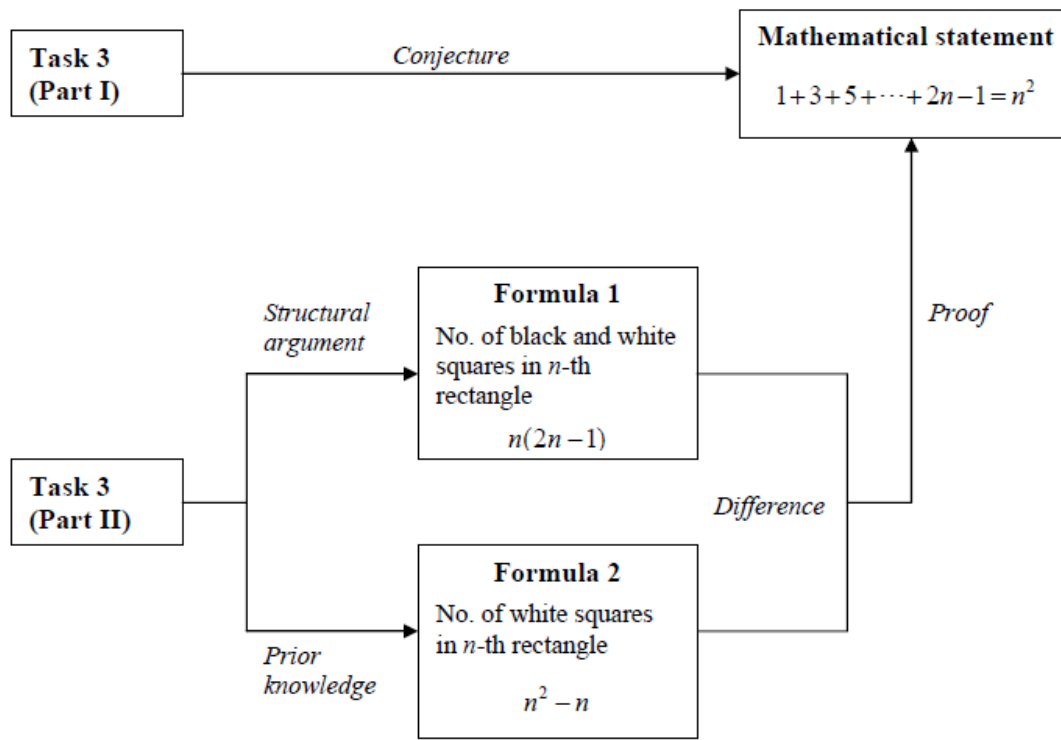

Figure 6.3. Intended connection between Part I and Part II of Task 3, aimed at formulation and justification of the mathematical statement,  $1 + 3 + 5 + \dots + 2n - 1 = n^2$

The number of black squares in the  $n$ -th rectangle,  $1 + 3 + 5 + \dots + 2n - 1$ , will then be given by the difference between the total number of squares in the  $n$ -th rectangle (as given by Formula 1) and the number of white squares in the  $n$ -th rectangle (as given by Formula 2).

The two groups treat the second part of Task 3 quite differently. I present the groups' engagement with the proof in the following paragraphs.

*Group 1's engagement with proof of a conjecture (Task 3, Part II)*

As explained in the previous section, the students of Group 1 have in Part I of Task 3 made a statement of a function (this is their conjecture). That is, they have symbolised the number of components (cubes) in the  $n$ -th staircase tower as  $F_n = n^2$ . When they start with Part II of the task, they treat it as a new generalisation task, where they interpret the goal as finding a formula for the  $n$ -th element of the pattern of rectangles: They establish a formula for the number of white squares in the  $n$ -th rectangle,

$n^2 - n$  (Formula 2), on the basis of guess and check. Further, they use the generalisation from Part I,  $n^2$ , to express the total number of components in the  $n$ -th rectangle as the sum of white squares and black squares, the result of which is  $2n^2 - n$  (Formula 1).

The students seem to be unaware of the role the rectangle pattern has in proving the conjecture from the first part of the task. This is indicated by Alice's utterance in turn 574 below (for transcription codes, see Appendix F). Figure 6.4 illustrates Group 1's engagement with Task 3.

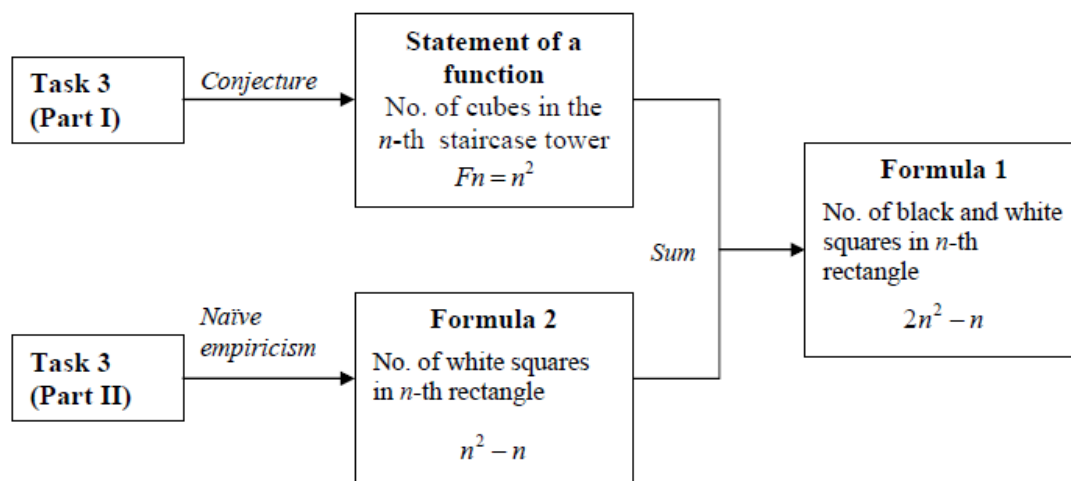

Figure 6.4. Group 1's engagement with Task 3, illustrating how they treat the connection between Part I and Part II of the task

574 Alice: The reason why we used  $n$  squared here [in Formula 1] is that we used  $n$  squared in the first part of the task. Then it was just carried forward down here.

575 Teacher E: Well, it was just carried forward. But then you haven't come any further in a way, because you have just carried the conjecture [from Part I of Task 3] forward.

[Task 3 (Part II), Group 1]

This means that they take as given (justified) what they were supposed to prove (their conjecture that the number of squares in the  $n$ -th staircase tower is equal to  $n^2$ ), which implies that the proof process collapses, as recognised by the teacher in turn 575.

What these students have produced (Formula 1) is an explicit formula for the total number of squares in the  $n$ -th rectangle of the shape pattern in Task 3 (Part II). There is no explicit requirement in Task 3f that the formula should be justified. The students are convinced by empirical reasons that Formula 1 is correct because it gives the expected numbers in several cases. There is, however, an introductory text to the second part

of Task 3 which makes clear that the aim of the second part of Task 3 is to prove the (conjectured) mathematical statement from the first part of the task:

The mathematical statement that you have formulated above is only based on a few observations. It is therefore just a conjecture. In order for it to become a justified statement, it needs to be proved. We will now look at a possible way to do this. [Introductory text, Task 3, Part II]

This information changes the didactical contract because, from an epistemological perspective, the introductory text adds constraints to the task. The presented aim of proving implies that Task 3f is not just a matter of finding explicit formulae by naïve empiricism; the formulae need to be established by theoretical reasoning (using axioms or previously proved theorems, or structural relationships).

The students' treatment of Task 3f as a new generalisation task (isolated from the first part of Task 3) as described above, shows that they, either, do not pay attention to the introductory text, or, that they do not know how to handle the implications of the introductory text with respect to establishment of the requested formulae. In either case, it is an instance of weakness in the milieu for establishment of generality in shape patterns. There is no feedback in the milieu that might inform their actions and guide them to establish a formula by utilising structural relationships. The didactical situation turns into a didactical situation when the teacher tells them that their formula is inadequate (turn 575).

*Group 2's engagement with proof of a conjecture (Task 3, Part II)*

Recall from the previous section that the outcome of Part I of Task 3 for Group 2 (as for Group 1) was the statement of a function, symbolised as  $a_n = n^2$  (this is their conjecture). That is, they have not formulated the teacher's intended mathematical statement of equality between the  $n$ -th square number and the sum of the first  $n$  odd numbers. During their engagement with Part II of the task, the students of Group 2 establish an appropriate expression for the total number of squares in the  $n$ -th rectangle (Formula 1) by a structural argument: They use a generic example to establish that the total number of squares of the  $n$ -th rectangle is equivalent to the product of  $n$  (width) and  $2n - 1$  (length). Since a generic example is a valid proof (Balacheff, 1988), Formula 1 can be considered justified. However, an expression for the number of white squares in the  $n$ -th rectangle (Formula 2) appears to be established by naïve empiricism, as indicated by the excerpt from the students' dialogue below. The exchange takes place after Paul has written a formula for the number of white squares in the  $n$ -th rectangle, succeeded by examples where the formula is evaluated for certain values of  $n$  (Figure 6.5 on the next page).

$$a_n = n(n-1)$$

$$3(3-1)$$

$$4(4-1)$$

$$5(5-1)$$

Figure 6.5. Paul's formula for the number of white squares in the  $n$ -th rectangle, succeeded by examples where the formula is evaluated for certain values of  $n$  (positions)

- 249 Anne:  $n$  times  $n$  minus one?  
 250 Paul: Look at the second figure [Pause 1-3 s] It is [indecipherable]  
 251 Helen: Yes, this is correct now.  
 252 Anne: Well? Yes.  
 253 Paul: Figure number two is [Pause 1-3 s]  $n$  is equal to 2.  
 254 Anne: Yes.  
 255 Paul: If you put 2 in, put 2 minus 1 in [evaluating the expression  $n(n-1)$  for  $n = 2$ ]  
 256 Anne: Well, I can see that you have put [2] in, but I have to kind of see it [Pause 1-3 s] *understand* it  
 257 Helen: But how did you figure it out [to Paul]?  
 258 Anne: yes?  
 259 Paul: Well, how shall I put it? [Pause 1-3 s] In the second figure, I thought it was something about  $n$ . But how I figured it out, I don't know.

[Task 3 (II), Group 2]

The continuation of the dialogue shows that they agree that Paul's formula is correct because it gives the expected value (the number of white squares of the elements in the rectangle pattern) in several cases. This implies that Group 2's formula for the number of white squares is justified by naïve empiricism and therefore not proved (Balacheff, 1988).

Then they represent the number of black squares by the difference between the total number of squares and the number of white squares in the  $n$ -th rectangle. But because Formula 2 is not proved, the proof process collapses and, hence, the conjecture is not justified. The lack of rigor in their argument is illustrated by dotted lines in Figure 6.6 (on the next page). The students, however, do not experience this deficiency, and believe, because they have found the number of black squares in the  $n$ -th rectangle to be equal to  $n^2$ , that they have proved the conjecture from the first part of the task:

- 274 Anne: Black squares, then we just take the total number minus the white ones, because by this we prove that, then we will see if it is in agreement with the other formula [ $a_n = n^2$ ]

∞

285 Anne: Yes indeed, it is the same. That's why it was written that we were going to prove it. (Paul: yes). That's what we have done now.  
 286 Paul: Right.  
 287 Helen: Uh huh.  
 [Task 3 (Part II), Group 2]

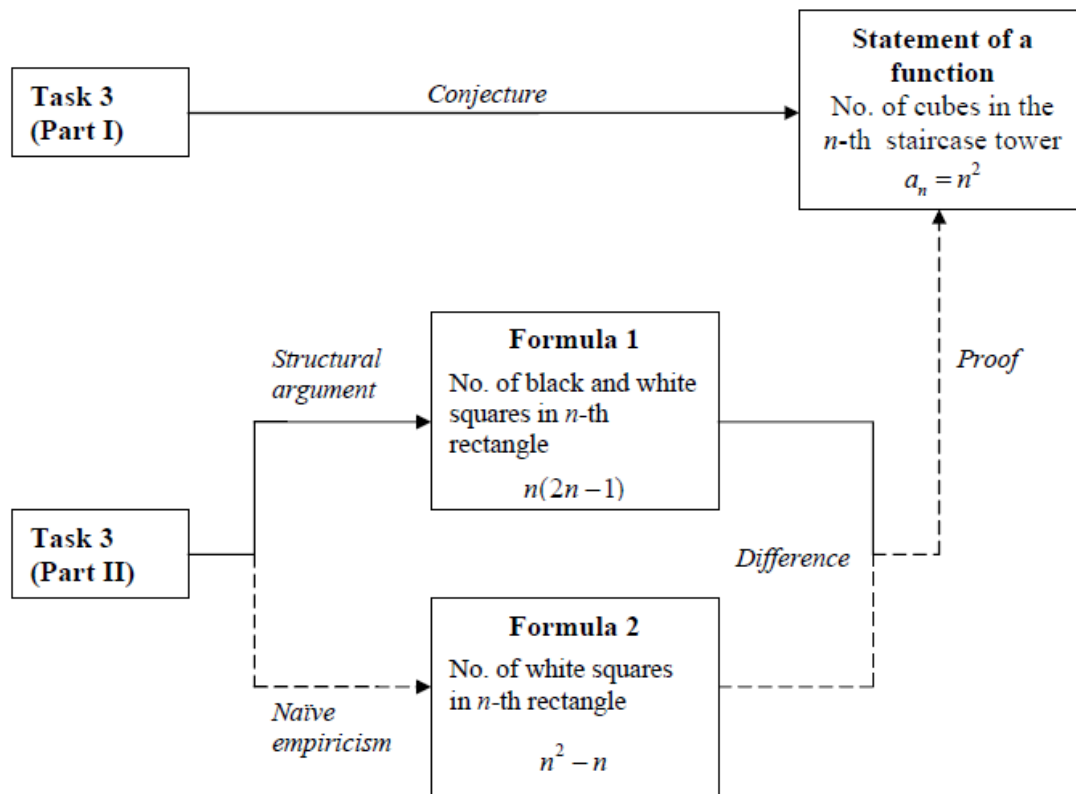

Figure 6.6. Group 2's engagement with Task 3, illustrating how they treat the connection between Part I and Part II of the task

Group 2 follows the structure of a proof as motivated by the design of Task 3. It is relevant to remark that because the students have made the statement of a function instead of a theorem (Part I of Task 3), they may not see the need for a proof. However, the data I have collected do not enable me to investigate how their engagement with the proof might have been different if they had proposed a theorem in Part I of the task. The problem with Group 2's treatment of the task is that they seem unaware that proving a conjecture depends on justification of each statement

(Formula 1 and Formula 2) that constitutes the argument.<sup>87</sup> The students have found the same symbolic expression for the general member of the sequence mapped from the shape pattern in two different ways. According to their reasoning this implies that the symbolic expression is correct (turn 285). But, as explained above, the statement constituted by Formula 2 appears to be established by guess and check and is, therefore, not justified.

*Comments on the process of proof*

The only feedback provided by the milieu is the students' verification that the conjectured formulae are correct in particular cases (naïve empiricism). That formulae established by naïve empiricism are inappropriate constituents of mathematical proofs is not made clear to the students through the objective milieu; it is only through the teacher's intervention they are made aware of it. The proof of the conjecture is orchestrated through Task 3f and Task 3g, in which the students might be guided to find the appropriate formulae and do the appropriate operation. There is, however, no guidance in the task about mathematically valid ways to establish the desired formulae.

The students do what they believe is their obligation according to the didactical contract; to produce solutions to the given mathematical tasks, one at a time. Task 3h ("Discuss if the conjecture from earlier in the task can be considered proved now") is designed to trigger them to take a broader perspective and to reflect on the task as a whole; that is, if the conjecture from earlier in the task can be considered proved after they have done Part II. As a response to Task 3h, students of Group 1 have the following conversation:

- 787 Alice:            Now it is proved because we have indeed gone the whole way once more.
- 788 Sophie:          Yes.
- 789 Ida:              But the way we started, why wasn't it proved then?
- 790 Alice:            Because we hadn't taken the complete, heavy way as we have done now.
- 791 Ida:              I don't quite understand what heavy way we have gone.

---

<sup>87</sup> The conjecture formulated by the students in Part I of Task 3 is a function (not a theorem as required). The students then conceive the proof (required by Part II of Task 3) to be established by the observation that they arrive at the same expression via the pattern of rectangles as they found in the first part of the task (i.e.,  $n^2$ ).

792 Alice: Because now we didn't look only at [Pause 1-3 s] we did not look, we hadn't drawn them all and [Pause 1-3 s] well, here it may be a connection, and there it may be a connection. We rather looked at, we considered a single one and found out that it applied for all.

[Task 3 (Part II), Group 1]

Alice's answer (turn 790) to Ida's question about what distinguishes their original formula from the one developed by the teacher's guidance gives no substantial information. Alice's explanation just repeats what she has already said, that it is proved because they have taken the "heavy way". It says nothing about the different character of the two formulae in terms of why the second formula is valid whereas the first is not. In her response to Ida's not understanding what is meant (turn 791), Alice does however to some extent use the character of a generic example (turn 792). This will be further discussed in Section 8.3.

As a response to Task 3h (consideration whether their conjecture is proved), students of Group 2 claim that, because they have got the same symbolic expression in Part II as in Part I of the task, they have proved the conjecture from Part I:

280 Anne: I get  $n$  squared, and that is equal to what we got [initially].  
 M  
 284 Anne: [indecipherable] what we have [indecipherable] [Anne turns one page back and points at something written in her notes, possibly the proposed formula  $a_n = n^2$ ]  
 285 Paul: it will be the same [indecipherable]  
 286 Anne: Yes, indeed, it is the same. That's why it is written that we were supposed to prove it. (Paul: yes). That's what we have done now.  
 287 Paul: Yes (Helen: uh huh)  
 288 Anne: [Anne looks in Helen's notes] Because I have got it by calculation and then [Pause 1-3 s]  
 289 Helen: [indecipherable] I have evaluated it for a number. [Helen has evaluated the new formula for the black squares,  $n(2n-1) - n(n-1)$  when  $n = 3$ ]

[Task 3 (Part II), Group 2]

They agree that because they have got the same expression ( $n$  squared), they have proved the conjecture from Task 3d (that the number of components of the  $n$ -th staircase tower is equal to  $n$  squared).

Neither of the groups reflect on Task 3 as a whole by discussing the role of Part I and Part II and the implications thereof; there is no discussion of the nature of a mathematical proof in this context. The analyses of the students' engagement with Task 3 presented in this section show that the idea of proof in Task 3 as intended by the teacher is not apparent

for the students. This is a property of the objective milieu (see Section 2.4.4) arising from the design of Task 3.

*Comments on characteristics of the objective milieu (Sections 6.1.1 and 6.1.2)*

The analyses of the students' engagement with Task 3 have pointed to some constraints of the students' formulation and justification of algebraic generality: The didactical milieu does not have an adequate feedback potential that could provide the students with opportunities to adjust their actions. That is, there is no feedback in the milieu that would make the students experience the inadequacy of the function  $f(n) = n^2$  they have produced (Task 3, Part I). Further, there is no feedback in the milieu that would make the students experience the inadequacy of their solution to the intended justification of the mathematical object they have produced (Task 3, Part II). The milieu does not have qualities to function as the student's antagonist system (opponent) in the learning process (see Section 2.4.4). This can be concretised by two features: First, the didactical milieu does not include a receiver of messages, which the student must send in order to attain the fixed goal (in the situation of formulation, Part I of Task 3). That is, appropriate solutions to subtasks do not provide an appropriate milieu to produce the target knowledge which is a mathematical statement about relations between odd numbers and square numbers. Second, the didactical milieu does not include an antagonist (opponent) by whom the student must be confronted in order to attain the fixed goal in an exchange of opinions (in the situation of validation, Part II of Task 3). That is, the students use naïve empiricism as their logic of generalisation, and the milieu does not provide feedback that would make them experience the insufficiency of this approach. Complexity of transcending naïve empiricism will be elaborated in Chapter 8, where I develop the analytic category *Complexity of operating in the situation of validation*.

In the next section I present the second subcategory of *Constrained feedback potential in didactical situations*.

## **6.2 Features of the milieu arising from lacking clarification of the concepts of “mathematical statement” and “generic example”**

Four tasks on algebraic generalisation of shape patterns were given to the students in two consecutive mathematics classes (each class was divided into four lessons). The students engaged with Task 1 and Task 2 in the first four lessons and with Task 3 and Task 4 in the next four lessons a week later. These classes were the first (and only) classes on algebraic generalisation of shape patterns. The epistemological analysis of the



mathematics potential in the tasks presented in Chapter 5 showed that the tasks were different in terms of the kind of generalisation they aimed at: Task 1, Task 2, and Task 3 (Part II) aim at formulae for the general member of the sequence mapped from the respective shape patterns; Task 3 (Part I) and Task 4 aim at mathematical statements which express relations between sets of numbers (equivalence of two expressions) as illustrated in the respective shape patterns. (For a complete collection of tasks, see Appendix A).

In this section I present the second subcategory of *Constrained feedback potential in didactical situations*. The subcategory is concerned with how students' generalisation processes are constrained by lack of clarification of the concepts of "mathematical statement" and "generic example". The phenomenon described by this subcategory is manifested in three different circumstances: in the students' establishment of a formula for the numerical value of the  $n$ -th element of the shape pattern instead of a theorem about an equivalence relation between square numbers and sums of odd numbers (as illustrated by the  $n$ -th element of the shape pattern); in the teacher's use of a generic example without the students' awareness of its meaning; and, in Topaze effects resulting from lack of existence of a conjecture.

### 6.2.1 Establishment of a formula for the numerical value of an element instead of a theorem about equivalence of two expressions

The teacher presents the students with the task of formulating a mathematical statement. In so doing, the teacher, it appears, seeks an object of a particular mathematical quality. My analysis leads me to conjecture that the students' understanding of the task does not match the teacher's requirement. To support this conjecture I need to examine what the students produce, and relate it to the character of a mathematical statement, as presented in Section 5.1.

#### *Group 1's engagement with Task 3 (Part I)*

During Group 1's engagement with the first part of Task 3 (see Figure 6.2 above), Sophie has constructed a table as shown in Table 6.1.

**Table 6.1: Number of components of the first five elements of the shape pattern, as produced by Sophie**

N	1	2	3	4	5
number	1	4	9	16	25

The students have verbalised that the number of components of an element in the staircase tower pattern is equal to the square of its position. The excerpt from the dialogue below shows how they use this to estab-

lish a formula for the general member of the sequence mapped from the shape pattern as a function of its position:

- 36 Ida: The formula just has to be [Pause 1-3 s]  
37 Sophie: What do we write first?  
38 Ida:  $n$  squared  
39 Alice: You can take  $f n$  then  
40 Sophie:  $f n$  [Pause 1-3 s]  $f$ ?  
41 Alice: the number of the shape  
42 Sophie: yes [Pause 1-3 s] is equal to  
43 Ida: is equal to  $n$  squared [Sophie writes  $F_n = n^2$ ]  
44 Sophie: is equal to  $n$  squared (Alice: yes)  
M  
49 Sophie: It's just a matter of putting in [values for  $n$ ] here then. Shape number, let's say shape number seventeen? Does someone have a calculator?

[Task 3 (Part I), Group 1]

As accounted for in Section 6.1.1, the teacher's intention with Task 3 is the students' establishment of a mathematical statement about equivalence of two expressions. Concretely, it aims at establishing that the sum of the first  $n$  odd numbers is equivalent to the  $n$ -th square number. In this form, the mathematical statement has the property of being a theorem which expresses an equivalence relation between square numbers and sums of odd numbers, a mathematical relation which is not self-evident and therefore needs to be proved.

The students however, when establishing the formula  $F_n = n^2$ , are not making the statement of equality of two quantities. For them the formula seems to be a self-evident truth. It is a function which to every natural number  $n$  (position in the sequence) ascribes a unique number,  $n^2$ . In turn 49 Sophie emphasises the nature of the formula as an algorithm for calculation. Because the formula does not make explicit use of hypotheses about odd numbers or of previously proved theorems, the formula is a principle assumed to be true (for empirical reasons). According to the epistemological analysis presented in Section 5.1, their formula is therefore a postulate, not a theorem. That is, the students of Group 1 have produced a statement of a function, which is a postulate about the numerical value of the general element of the staircase tower pattern.

When they come to Task 3d, which is about expressing a mathematical statement based on what the shape pattern seems to show, they are insecure about the notion "mathematical statement". When teacher Erik, on his own initiative, enters the room, the following conversation takes place:

- 106 Ida: A mathematical statement? We have made a formula for [Pause 1-3 s] but how do you make a mathematical statement?
- 107 Teacher E: Well, a formula is a mathematical statement if it [Pause 1-3 s]
- 108 Ida: Yes, because we have made it with symbols actually.
- [Task 3 (I), Group 1]

Ida's utterance in turn 108 suggests that she interprets the teacher's conditioning in turn 107 to mean that a formula is a mathematical statement if represented by (mathematical) symbols. The characteristics of a mathematical statement are never made explicit by the teacher during the time spent on Task 3 and Task 4. The teacher's response to the conjectured formula,  $F_n = n^2$ , is:

- 114 Teacher E: Well ok, so it is [Pause 1-3 s] yes exactly, it, it is an expression for the total number of [Pause 1-3 s] squares in [Pause 1-3 s] in shape number  $n$ . Uh huh [Pause 1-3 s] ehm [Pause 1-3 s] that's fair enough [Pause 1-3 s] ehm but ehm then you could think, could you have expressed [Pause 1-3 s]?
- 115 Ida: The same thing with words?
- 116 Teacher E: Well, or expressed the total number in another way, by thinking about how this shape is built up?

[Task 3 (Part I), Group 1]

Turns 114 and 116 show how the teacher tries to direct attention towards the structure of the elements of the shape pattern; that is, how the elements can be decomposed invariantly into repetitive parts, as explained in Section 5.1. However, the teacher's focus in turns 114 and 116 on total number of components may reinforce the students' conception that the task is about the numerical value of the general element of the shape pattern.

As explained in Section 5.1, a mathematical statement is a theorem which can be proved on the basis of explicit assumptions. In Task 3, the (intended) explicit assumptions are that the rows of the general staircase tower have odd numbers of components: 1 at the first row; 3 at the second; 5 at the third; and,  $2n - 1$  components at the  $n$ -th row. Further, the relevant arithmetic operation (to get the total numbers of components) is addition of these odd numbers. The mathematical object aimed at in Task 3 is the statement of equivalence of two different algebraic expressions for the numerical value of the general element of the shape pattern. The nature of this mathematical object (an equality) is different from the nature of a formula for the numerical value of the general element of the shape pattern. This issue is, however, not addressed in the course of the observed algebra lessons.

### *Group 2's engagement with Task 3 (Part I)*

The engagement of Group 2 with the first part of Task 3 also makes evident insecurity about the notion of a mathematical statement. They work independently of the teacher in this episode:

- 72 Helen: Express what the shapes seem to show, as a mathematical statement in words? [Pause 1-3 s] Ehm.
- 73 Anne: We have probably written it in a way that [Pause 1-3 s] ehm [Pause 1-3 s] there are  $n$  squared number of cubes in the  $n$ -th shape.
- 74 Helen: Right.
- 75 Anne: Express what the shape seems to show as a [Pause 1-3 s] Well, it is the square then of [Pause 1-3 s] of [Pause 1-3 s] the shape [indecipherable]. Mathematical statement [Pause 1-3 s] [Anne turns towards Paul] Do you have any formulation of a mathematical statement?

[Task 3 (Part I), Group 2]

Anne's utterances in turns 73 and 75 show that the students have found a formula that expresses that the number of components of the  $n$ -th element is equal to  $n$  squared. The excerpt from the dialogue below suggests that even if they are insecure, they find it unlikely that a mathematical statement should be more complicated than just an expression of the number of components of the general element:

- 87 Helen: Isn't that  $n$  squared or? [laughs a bit]
- 88 Anne:  $a_n$  is equal to  $n$  squared?
- 89 Helen: Yes.
- 90 Paul: It has to be like that [Pause 1-3 s]
- 91 Anne: [Element] number  $n$  is equal to  $n$  squared. Well? Can't believe it is supposed to be more complicated?

[Task 3 (Part I), Group 2]

### *Comments on both groups' achievement related to Task 3 (Part I)*

The students of both groups have identified the numerical values of the rows of a staircase tower to be odd numbers and the numerical value of the staircase tower as a whole to be a square number. However, when they are asked to formulate a mathematical statement (intended to be an equivalence relation between square numbers and sums of odd numbers), they come up with a formula for the general member of the sequence of numbers mapped from the shape pattern. Whereas Group 1 denotes the general member by  $F_n$  (i.e., "function-like" notation), Group 2 denotes

it by  $a_n$  (i.e., conventional notation for the  $n$ -th member of a sequence)<sup>88</sup>. The function produced by the groups is an empirically based conjecture about the general member of the sequence mapped from the shape pattern which says nothing about the arithmetic relations attempted to be illustrated by the elements of the staircase tower pattern. It is a formula for the numerical value of the  $n$ -th element.

The incomplete achievement in the situation of formulation can be explained by two factors. First, there is a problem with the students' (of both groups) prior knowledge because they do not know the nature of a mathematical statement. Neither is the nature of a mathematical statement explained by the teacher during his interaction with the groups. Second, there is no feedback potential in the objective milieu that could support their appropriation of the concept of mathematical statement (and approve their formulation). I conjecture that the students perhaps would benefit from a specification (either in the task or by the teacher's intervention) what it was intended to be a statement *about*; that it was intended to be a statement about equality (i.e., a statement of equivalence of square numbers and sums of odd numbers).

Teacher Erik explained in a conversation after the lesson (RJ\_06.02.2004) that he had used the concept of mathematical statement in Task 3 and Task 4 in the meaning of "theorem". His rationale for using the concept of mathematical statement was that it was likely to appear easier for the students because it was closer to natural language than the word theorem (conceived lower threshold).

That the students remain unaware of the nature of a mathematical statement is detrimental to the situation of formulation because it deprives them of the possibility to formulate a conjecture about number theoretical relationships. The connection aimed at in Task 3 is a theorem about equality of the  $n$ -th square number and the sum of the first  $n$  odd numbers;  $1 + 3 + 5 + \dots + 2n - 1 = n^2$ . Task 4 aims at a theorem about equality of  $n$ -th square number and the sum of the  $n$ -th and the  $(n - 1)$ -th triangular numbers;  $T_n + T_{n-1} = n^2$ , with  $T_n = 1 + 2 + 3 + \dots + n$ . These connections are equivalence relations between elements of particular sets of numbers. It is theoretical knowledge decontextualised from the shape patterns from which the equivalence relations emerge. The knowledge

---

<sup>88</sup> Given that a sequence is a function on the set of natural numbers,  $a_n$  could also be regarded as functional notation.

developed by the students, however, is formulae for numerical values of the general element of the given shape patterns. It is empirical knowledge contextualised by the shape patterns from which the formulae emerge.

As explained above, the outcome from both groups' engagement with the first part of Task 3 is the function  $f(n) = n^2$  (this expression I will use to refer to the function produced by the groups, even if the notation used by the groups is  $F_n = n^2$  and  $a_n = n^2$ ). This function is not a conjecture that needs to be justified by a mathematical proof. It is a formula established on the basis of counting the components of the first few elements of the shape pattern and inferring by naïve empiricism that the numbers are square numbers. Hence, the milieu for the situation of validation is inadequate; there are no conjectures that need to be justified. For the students of Group 1 the adidactical situation collapses and turns into a didactical situation by teacher Erik's interventions. This teaching situation produces Topaze effects, a phenomenon that will be presented in Section 6.2.3. The students of Group 2 continue on the second part of the task (the proof) without knowing that the mathematical object they have produced is not the one aimed at.

The second part of Task 3 is intended to establish a theorem through a mathematical proof. When the students of Group 2 engage in the situation of validation they follow the steps described in the task: They express the number of components of the general element of the staircase tower pattern as the difference between the number of components of the general elements of two other shape patterns (rectangle and triangular numbers). The result of this process is the  $n$ -th square number, which the students interpret as the intended outcome: They have found, in another way than counting, that the number of components of the  $n$ -th element of the staircase tower pattern is equal to the  $n$ -th square number. There is nothing in the milieu that challenges them to propose any connection between square numbers and odd numbers. The target mathematical knowledge, the theorem which expresses that  $1 + 3 + 5 + \dots + 2n - 1 = n^2$ , has disappeared. It was dependent on the students' knowing what was meant by a mathematical statement. When this failed to be the case, the students were prevented from achieving the intended learning.

In the next section I present the second manifestation of *Features of the milieu arising from lacking clarification of the concepts of "mathematical statement" and "generic example"*.

### **6.2.2 A generic example for the teacher but not for the students**

In this section I present the analysis of Group 2's engagement with Task 4 (Figure 6.7 on the next page). I will explain how the students' unawareness of the nature of a mathematical statement, combined with the

teacher's use of a generic example without the students' awareness of it, leads to degeneration of the algebraic generalisation process.

Task 4



Thorvaldsen's museum in Copenhagen contains several floor mosaics with mathematical content. We looked at one mosaic last Friday, and here we shall look at another one. (The picture is reproduced from the book *Matematik til tiden* by Bjerg et al., 2000).

This pattern can be thought of as built up by equal squared areas containing bright and dark mosaic tiles. On the shape below the pattern is reproduced schematically with ■ for each of the dark squared tiles and □ for each of the bright ones.

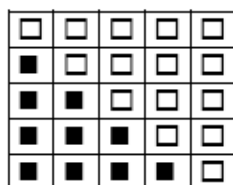

- If this shape were part of a sequence of shapes, what would the next one look like?
- What kinds of figurate numbers do you find in the bright and the dark areas, and in the shape as a whole?
- Express what the shape tells you about these numbers in terms of a mathematical statement.

Figure 6.7. Task 4

The students have drawn what they define to be the first three elements of a shape pattern (Figure 6.8 on the next page). They have found that for the first element of this shape pattern (a 5x5 square), the number of black tiles is equal to the sum of the first four natural numbers, and the number of white tiles is equal to the sum of the first five natural numbers. The students have observed that this is a regularity that applies also for the next two elements of the shape pattern. That is, they have verified by inspection that for the second element (a 6x6 square), the number of black tiles is equal to the sum of the first five natural num-

bers, and the number of white tiles is equal to the sum of the first six natural numbers, and likewise for the third element. They have, however, not identified the sums of natural numbers to be triangular numbers.

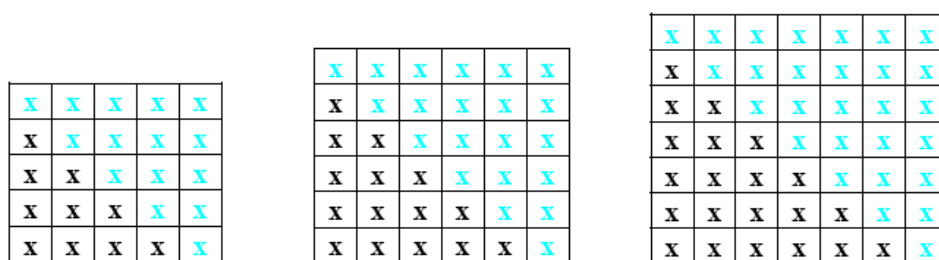

Figure 6.8. Continuation of the shape pattern invented by Group 2 (Task 4a)

When they come to Task 4c, they wonder what is meant by “figurate number” and “mathematical statement”, and get teacher Erik to help them. Teacher Erik explains that the question about figurate numbers is about being down on the “bedrock” looking for standard numbers that it is common to have in one’s “toolbox”. The teacher thereafter asks what the students recognise if they look at the first element as a whole. The subsequent exchange which takes place is this:

- 591 Paul: Well, that it is five squared.  
 592 Teacher E: Right.  
 593 Anne: Yes, it is indeed squares, and then [Pause 1-3 s]  
 594 Teacher E: Yes, it is indeed squares, square numbers.  
 595 Paul: And then you have nine and sixteen as the numbers of [Pause 1-3 s] no, ten perhaps?  
 596 Teacher E: And then there are the black and white ones? Do you recognise them?  
 597 Anne: Fifteen, twenty one [Pause 1-3 s] ehm [Pause 1-3 s]

[Task 4, Group 2]

In turn 591 Paul focuses on the first element (a 5x5 square) of the shape pattern. I interpret his words here to suggest that he continues to look at this element in turn 595 and refers to the number of black and white tiles of the 5x5 square. The numbers he suggests at first are wrong, but he then makes a new suggestion which is right for the number of black tiles of the first element. The teacher does not directly respond to Paul’s contribution, and when the teacher asks if they recognise the black and white tiles (turn 596), Anne responds by giving the number of black and white tiles of the second element. This seems to make Paul insecure about what the teacher asks for; he wonders whether it is only the first element or it is the sequence of elements they are supposed to consider:

- 598 Paul: If we are supposed to see the connection, it is only *this* very shape we shall look at now? [Draws a curve with his pencil



around the element given in the task] It is not the next shapes we have made [points at the succeeding elements drawn in his notebook when he says “next”]?

599 Teacher E: You may well look at it as it stands there [Pause 1-3 s] uh [Pause 1-3 s] [indecipherable]

600 Paul: Not further, ok.

[Task 4, Group 2]

I interpret the teacher’s response in turn 599 as confirming that it is satisfactory that the students look at the element given in the task (the 5x5 square) as a basis for finding answers to Tasks 4b and 4c. It is plausible that the teacher takes this stance as a consequence of seeing the 5x5 square as a generic example. This element of the shape pattern is an example which illustrates that the sum of the fourth and the fifth triangular numbers is equal to the fifth square number. It is generic in the sense that it is a representative of a class of elements which have the property that they are squares which illustrate that the  $n$ -th square number is the sum of the  $(n - 1)$ -th and the  $n$ -th triangular numbers.

It is important for the analysis of the students’ outcome of engagement with Task 4 to note that these general properties are not addressed in the classroom situation. In the presentation of my analyses, when I refer to examples as being generic, it is a consequence of my conceptualisation of them as having this character, not because the teacher or the students refer to them as being generic. The teacher does not express to the students that he uses the 5x5 square in the sense of a generic example, nor does he use the terms “generic example” or “generic”. The utilisation of a generic example appears to be implicit in the teacher’s approach. The stance taken by the teacher about the sufficiency of looking at one element of the shape pattern (genericity of the 5x5 square) is consistent with the formulations in the task, a correspondence which may be expected since the task is designed by the same teacher. Applications (in Task 4) of grammatical number *singular* as manifested in the notion “the shape” are indications that the presented element (5x5 square) is seen as generic:

What kinds of figurate numbers do you find in the bright and the dark areas, and in *the shape* as a whole? [Task 4b, emphasis added]

Express what *the shape* tells you about these numbers in terms of a mathematical statement. [Task 4c, emphasis added]

After having observed that the 5x5 square contains ten black tiles and fifteen white tiles, they look at the next elements of the shape pattern. They observe that the elements develop by adding to the white tiles an extra row (at the top) with one more tile, and that the number of black tiles of a successive element is the same as the number of white tiles of the present element. The teacher reminds the students that they have ear-

lier written ten as a sum of the first four natural numbers, and further, tells them that numbers with this structure are referred to as triangular numbers. He refers to what I interpret as (for him) a generic example when he continues:

640 Teacher E: So this is actually the clue here. That this element, I think I'll just tell you, that this shape represents a kind of connection between triangular numbers and square numbers.

[Task 4, Group 2]

This is succeeded by a comment by Anne that she had been insecure what was meant by the concept of “figurate numbers”. After some exchanges between the teacher and her, she turns attention to the concept of mathematical statement in Task 4c:

651 Anne: Express what the shape tells about these numbers in terms of a mathematical statement [recitation from the task]. Are we supposed to write it as a formula or shall we formulate it?

[Task 4, Group 2]

The teacher responds by reinforcing attention towards the same element (the 5x5 square), which I suggest the teacher is using as a generic example:

652 Teacher E: Well, then you can think of that one. [He points at the 5x5 square presented in the task] If you look at it as a whole, what square number is it that it [Pause 1-3 s] shows us? [Pause 1-3 s] What position?

653 Helen: Five or?

654 Anne: What number in the series or?

655 Teacher E: What number in the series of square numbers, right.

656 Anne: Well, I can imagine it is [Pause 1-3 s] the fifth then.

657 Teacher E: The fifth, right.

658 Anne: Because that would have been good for us [smiles]

659 Teacher E: Yes. [Students laugh] Well, but here we don't have much choice, really. It is the fifth, it is twenty five, it is square number five. (Anne: uh huh). And if we think of it as composed by triangular numbers (Anne: yes) then you can think of [Pause 1-3 s] what position in the series of triangular numbers is that which these black and white [components] represent?

[Task 4, Group 2]

I interpret the teacher's responses in turns 652, 655, 657, and 659 as constraining the students' possibilities to develop the knowledge aimed at (a theorem which asserts equivalence of square numbers and sums of two consecutive triangular numbers). The interpretation is grounded in two circumstances. First, the nature of a mathematical statement has not been explained. The analysis presented in the previous section showed that the outcome of students' engagement with Task 3 was a formula for

the number of components of the general element of the shape pattern instead of (as intended by the teacher) a mathematical statement about equivalence of two different expressions for the number of components of the general element. During engagement with Task 3 there was no feedback in the milieu that had the potential to challenge the students' formula and adjust their conception of a mathematical statement. Based on that experience, it is plausible that the students, during engagement with Task 4, remain unaware that the mathematical statement aimed at is a theorem about equivalence of two different expressions for the number of components in the general element of the shape pattern.

Second, the fact that at the teacher uses a generic example apparently without the students' consciousness about it, contributes to the students' comprehension of the particular example as representing a mathematical statement in its own right. Teacher Erik leaves the group room after turn 659 (in the transcript above), and the students collaborate to find the positions of the triangular numbers from which the fifth square number is constructed. The outcome of their engagement with Task 4c is the expression in natural language of the property of one particular shape; the fifth square number is constructed from the fourth and the fifth triangular numbers. They make no attempt to generalise this characteristic to apply to all elements of the shape pattern, neither in natural language, nor in algebraic notation.

682 Paul: Well, a person who could figure out a *formula* for this, he would be good [laughs].

683 Anne: No, but it is not written (Paul: no) that we shall have a formula (Paul: yes). We are supposed to express it as a mathematical statement. We have done that now. It is not very good, but we have emphasised what is relevant, I think.

[Task 4, Group 2]

Recall that Anne asked teacher Erik if they were supposed to write the mathematical statement as a formula or just formulate it (turn 651 in the transcript on the previous page). Paul's and Anne's utterances (turns 682 and 683 in the transcript above) indicate that they have interpreted the teacher's response in turn 652 (previous page) to mean that a mathematical statement in this context is meant to be just a *formulation* about the numbers in the particular shape. Paul's utterance in turn 682 indicates, by the emphasis of the word "formula" and the way he laughs, that he thinks it may be impossible to establish a formula that expresses what the element presented in the task tells you about the numbers involved. It is plausible that their stance is influenced by what they possibly interpret as the teacher's rejection (turn 652) that the intended mathematical object is a formula.

What is reported above shows how the generalisation process intended in Task 4 collapses. The students remain unaware that the aim of the task is to establish a theorem about a number theoretical relationship (equivalence of square numbers and the sum of two consecutive triangular numbers). The generalisation process is obscured by two factors: The first is a lack of clarification of what is meant by a mathematical statement; the students interpret the teacher to mean that they shall not find a formula, but formulate a connection in natural language. The second factor is the use of the singular form of the noun “shape” in Task 4c, accompanied by what the students’ interpret as the teacher’s confirmation that they can just consider the 5x5 square. Underlying both factors is what I interpret to be the teacher’s use of a generic example without the students’ awareness of it. The described factors are detrimental to the generalisation process in the way they steer the students’ attention away from generality and towards particularity.

The students’ unawareness of the nature of a mathematical statement and the teacher’s use of a generic example without the students’ awareness of it, are features of the milieu which constrain the students’ possibility to solve the problem in the reference situation (the task designed by the teacher). When Anne asks the teacher what is meant by a mathematical statement, it indicates that the didactical situation devolved to the students is not appropriate because it depends on knowledge which the students do not have. The teacher, however, instead of giving them the definition of a mathematical statement, directs attention to the 5x5 square. This I interpret as an attempt from the teacher to try to keep the didactical relationship intact and rescue the didactical situation by not telling the students the answer (thereby reinforcing their possibility to find the answer themselves).

It is relevant that the teacher believes that the students know the concept of mathematical statement (RJ\_06.02.2004). It is therefore plausible that he interprets Anne’s question after she has recited Task 4c (turn 651) to signify a problem with seeing the structural relationships of the elements of the shape pattern, and not a problem with the concept of mathematical statement *per se*. For that reason, when he responds to the students’ questions, he tries to help them discover the structure of the elements (by utilising a generic example) so they can develop the knowledge aimed at; an equivalence relation between square numbers and the sum of two triangular numbers. But, as described above, the students’ interpretation of the teacher’s (generic) example as complete in itself, without attention to general properties, terminates the generalisation process. Another incidence of the teacher’s use of a generic example without the students’ awareness of it is included in the next section.

In the next section I present the third manifestation of *Features of the milieu arising from lacking clarification of the concepts of “mathematical statement” and “generic example”*.

### 6.2.3 Topaze effects resulting from students’ production of an unintended mathematical object

Section 6.2.1 showed that both groups, in the didactical situation concerned with Task 3d (“...express what the shapes seem to show, as a mathematical statement”), have made a formula for the numerical value of the general element of the actual shape pattern in terms of the function  $f(n) = n^2$ . As explained in Section 6.2.1, when teacher Erik observes that the students of Group 1 have made this function, he does not tell them that it is not a mathematical statement. Rather than directly refusing their formula, he acknowledges that what they have got is an expression for the total number of components in the general element. Further, he encourages them to express the total number of components of the general element in another way by directing their attention towards structure:

116 Teacher E: Well, or expressed the total number in another way, by thinking about how this shape is built up?

[Task 3 (Part I), Group 1]

After Sophie has expressed that the next element is built by adding a row to the current element (verbalised as “adding a line”), the following exchange takes place:

133 Teacher E: And then we build it line by line [Pause 1-3 s] So we are concerned with adding numbers [Pause 1-3 s] in order to get the total number [hesitantly] [Pause 1-3 s] Shape number two is one plus three [Pause 1-3 s] and the next shape is one plus three plus five [Pause 1-3 s]

134 Alice: So you [Pause 1-3 s] just increase all the time, so if [Pause 1-3 s] there is one (Teacher E: uh huh) one plus three (Teacher E: uh huh) one plus three plus five (Teacher E: uh huh) one plus three plus five plus seven (Teacher E: uh huh) one plus three plus five plus seven plus nine.

135 Teacher E: Yes, exactly.

136 Alice: And like this the whole way upwards.

137 Teacher E: And instead of saying this, what could you say that you are doing in this adding process? [Pause 1-3 s] Now you have said it with examples, one plus three plus five plus seven, but what are you actually adding here now? [Ida looks at Alice, then in Sophie’s notes]

138 Alice: The odd numbers in this series. [Alice has a cheerless facial expression]

139 Teacher E: Yes, so it is. Adding odd numbers. And what numbers do you get as an answer? [Teacher in an excited voice; Alice

- strokes her eyes] What kind of numbers do you get as an answer?
- 140 Alice: Square [Pause 1-3 s] what kind of numbers I get as an answer?
- 141 Teacher E: When you are adding the odd numbers in this way?
- 142 Alice: Square numb [carefully]
- 143 Teacher E: Then you will get a square number, indeed. This is almost a little discovery [Pause 5 s] which is at least such that [Pause 1-3 s] if I have asked, what happens if I add, what kind of numbers do you get if you add the first ten odd numbers? (Alice: uh huh). If I had asked you this question this morning, then you sure couldn't have answered: Then I'll get the tenth square number. [Alice shakes her head and says: no] So this is not something quite obvious, which you just know without any more fuss. This, you can say, is the idea of a mathematical statement, that nobody knows it without further thinking. A piece of work has to be done, and that is the process which has been going on here now, which [Pause 1-3 s] which is resulting in [Pause 1-3 s] it actually is like this, that if I add the first three odd numbers, I will get the third square number. [Alice and Sophie nod and say: uh huh. Ida leans her head in her arm, looking down at the table] Well, if I add the first four odd numbers, I will get sixteen, which is the fourth square number, oh yeah, connection in the world of numbers, in a way. [Ida nods and looks down at the table] It looks like this, as if it's going to be like this.

[Task 3 (Part I), Group 1]

In turn 133 the teacher claims that building an element of the shape pattern line by line corresponds to adding numbers, and offers the second and third elements as examples. Alice's responses in turns 134 and 138 are evidence that she understands that the teacher describes a sequence of sums of consecutive odd numbers. However, Alice's hesitation (turns 140 and 142) and her repetition of the question (turn 140) when the teacher asks what kind of numbers they will get when they add the odd numbers, indicate that she has not got a clear idea of the relationship between the sum of odd numbers and the resulting number. It may be that Alice's response in turn 134 is just a matter of repeating the structure (adding consecutive odd numbers) of which the teacher has given the first two examples. The fact that Alice does not relate ordered elements to her listing of the sums in turn 134 (as the teacher did in his examples in the preceding turn) supports the interpretation that she has not observed the *nature* of the relationship between square numbers and odd numbers (that the  $n$ -th square number is equal to the sum of the first  $n$  odd numbers).

I interpret what is described above as an instance of a Topaze effect (Brousseau, 1997): The teacher's intention is the students' appropriation

of the equivalence of the  $n$ -th square number and the sum of the first  $n$  odd numbers. The students have found (by extrapolating the number of components of the first few elements) that the total number of components of the general element is given by the  $n$ -th square number. The teacher tries to make them see that the total number of components can be constructed also by adding the number of components of each row (turn 133). The idea is that this would enable the students to conjecture that the  $n$ -th square number is equal to the sum of the first  $n$  odd numbers. The teacher asks what kind of numbers they add and what kind of numbers they get (turns 137 and 139). Alice gives correct answers (turns 138, 140, 142), though hesitatingly with respect to the kind of number they get. The teacher's questions about types of numbers are however not focused on the target knowledge (the equivalence relation) *per se*. They enable Alice to give appropriate answers without dealing with the original issue, the equivalence relation. This is an instance of a Topaze effect, the outcome of which is that the target knowledge has disappeared.

When the teacher in turn 143 reveals that the sum of the first ten odd numbers is equal to the tenth square number, I interpret him as using a generic example which for him is a representative of the equivalence relation between the  $n$ -th square number and the sum of the first  $n$  odd numbers. Later in the same turn he exemplifies this relation for  $n = 3$  and  $n = 4$ . When the teacher characterises Alice's preceding utterances as "almost a little discovery", it is an incidence of a Jourdain effect, which is a kind of Topaze effect. A Jourdain effect is characterised by the teacher's disposition to "recognize the indication of an item of scientific knowledge in the student's behaviour or answer, even though these are in fact motivated by ordinary causes and meanings" (Brousseau, 1997, p. 26). The teacher recognises in Alice's utterances the equivalence relation that he aims at, but there is no evidence in Alice's utterances that she is aware of the nature of the relationship between odd numbers and square numbers. Her hesitation in turns 140 and 142 suggests that she does not understand what the teacher is after.

Section 6.2 has presented a feature of the milieu arising from the students' unawareness of the nature of a mathematical statement. The concept "mathematical statement" is questioned by students in both groups, but is not clarified. This feature of the milieu has some important effects on the students' algebraic generalisation processes: First, it has been shown how the students establish a postulate instead of a theorem. This gives rise to a shortcoming in the milieu for validation, the analysis of which will be presented in Chapter 8. Second, it has been shown how the students' lacking awareness of the nature of a mathematical statement together with the teacher's use of a generic example without the stu-

dents' awareness of it, constrain the generalisation process. Third, it has been shown how the fact that the students have made the statement of a postulate (a formula for the number of components of the general element) instead of a theorem produces Topaze effects in the teaching situation.

In the next section I present the third subcategory of *Constrained feedback potential in didactical situations*.

### 6.3 Features of the milieu arising from incomplete institutionalisation of previous knowledge

In this section I present the third subcategory of *Constrained feedback potential in didactical situations*. The phenomenon described by this subcategory is manifested in three different circumstances: in a conjecture that has not been institutionalised and therefore is not reusable in a new context; in a “malformula” resulting from incomplete institutionalisation of syntax of recursive formulae; and, in the teacher's assumption about the outcome from a previous lesson which does not accord with the achieved outcome.

#### 6.3.1 Non-reusability of knowledge originated by Topaze effects

As explained in the previous section, teacher Erik has exemplified in natural language for the students of Group 1 the equivalence relation aimed at in Task 3. That is, he has told them that the sum of the first  $n$  odd numbers is equivalent to the  $n$ -th square number for particular values of  $n$  (i.e.,  $n = 3$ ,  $n = 4$ , and  $n = 10$ ). The teacher then writes down in mathematical symbols the equality in two particular cases and in the general case (in the last case he omits the expression for the  $n$ -th odd number) as shown in Table 6.2. Further, the teacher gives them the task of symbolising the  $n$ -th odd number. I will in Section 7.1.5 describe and analyse their attempt to represent the  $n$ -th odd number in algebraic notation. Now, I turn to the presentation of evidence of what I interpret as non-reusability of knowledge originated by Topaze effects.

**Table 6.2: The equivalence relation in two particular cases and in the general case, as written by teacher Erik in Alice's notebook**

$1 + 3 = 2^2$
$1 + 3 + 5 = 3^2$
$1 + 3 + 5 + \dots + \dots = n^2$

The students of Group 1 do not succeed in symbolising the  $n$ -th odd number whereupon they start to focus on differences between consecutive members of the sequence mapped from the staircase tower pattern.



They do not, however, reflect on the fact that these differences are odd numbers. So when they find that the increase from the  $(n - 1)$ -st member to the  $n$ -th member is given by  $n + (n - 1)$  they are not aware that this expression does indeed represent the  $n$ -th odd number.<sup>89</sup>

There are three incidents that might suggest that the students would see that the increase is an odd number. First, they have answered correctly the subtask about what numbers they find in the rows of the staircases; that is, they have observed that the number of components in each row is an odd number. Second, Alice has answered that it is odd numbers they add to get the total number of components in each element (turn 138 in transcript presented in the previous section). Third, the teacher has verbally (as explained above) and symbolically (as shown in Table 6.2) expressed that the number of components in each element of the shape pattern is built up by adding odd numbers. Nevertheless, the students do not combine the concept of increase from one element to the next with the actual arithmetic expression (Table 6.2) of the number of components of the elements they look at. That is, they do not utilise the observation that the  $n$ -th member of the sequence arising from the numbers of components of the elements is equivalent to the sum of the first  $n$  odd numbers (where the odd numbers denote the number of components of the rows) to conclude that the difference between the  $n$ -th and the  $(n - 1)$ -th elements is equal to the  $n$ -th odd number and therefore is given by  $n + (n - 1)$ .

The conjecture that the sum of the first  $n$  odd numbers is equal to the  $n$ -th square number has originated through Topaze effects as explained in Section 6.2.3. The origin of the conjecture (for the students) is Alice's correct answers to questions which are not focused on the target knowledge (the mentioned equivalence relation) and the teacher's recognition of these answers as indications that the target knowledge has been appropriated. Brousseau (1997) claims that for a theoretical conjecture to be institutionalised it must already have functioned as a conjecture in students' discussions as a means of establishing or rejecting proofs (pp. 161-162). At the stage in the didactical situation where the students have found that the difference between two elements is given by

---

<sup>89</sup> The students use the concept "increase" to refer to the (first) difference between consecutive members of the sequence mapped from the shape pattern. I will however use the concept "difference" in my text, as presented in Chapter 5.

$n + (n - 1)$ , the conjecture that the sum of the first  $n$  odd numbers is equal to the  $n$ -th square number has not (yet) functioned as a conjecture in the students' discussions. According to Brousseau, the mentioned conjecture has therefore not been institutionalised. Further, because it has not been institutionalised, it is not reusable in a new context. This explains why the students of Group 1 do not use the conjecture (that the sum of the first  $n$  odd numbers is equal to the  $n$ -th square number) to conclude that the difference they have found between two elements,  $n + (n - 1)$ , is equal to the  $n$ -th odd number.

In the next section I present the second manifestation of *Features of the milieu arising from incomplete institutionalisation of previous knowledge*.

### 6.3.2 A “malformula” resulting from incomplete institutionalisation of syntax of recursive formulae

Another incidence of incomplete institutionalisation of previous knowledge is when Group 1 struggle to write down the recursive formula which they have identified as representing the pattern of Task 3. As described above, they have found the difference between the  $n$ -th and the  $(n - 1)$ -th element of the pattern to be given by  $n + (n - 1)$ . But they do not know how to represent in mathematical symbols that the previous member plus the difference is equal to the current member. Instead of writing  $a_n = a_{n-1} + n + (n - 1)$ , with  $a_1 = 1$ , they propose that the formula is given by  $n + (n - 1) = n^2$ . They check the validity of the formula by looking at the case when  $n = 3$ . Alice has written  $3 + (3 - 1) = 3^2$  and says:

248 Alice: Five [Pause 1-3 s] What are we struggling with then? This is actually correct. The increase is indeed five.

[Task 3 (Part I), Group 1]

It is correct that the difference between the third and second member of the sequence of square numbers is five, but they fail to represent that it is the *sum* of the previous square number and the difference which is equal to the current square number. After a while they see the hopelessness of their suggested formula because the two sides need to be equal and this is not the case (the only number which satisfies the equation is  $n = 1$ ):

274 Alice: Because, actually it doesn't make any sense that five is equal to nine, in a way.

[Task 3 (Part I), Group 1]

It is relevant here to look at the background for their engagement with a recursive formula in Task 3. Task 3 is part of the assignment for the second day on which the students work on generalisation of shape pattern.

On the first day with generalisation of shape patterns (a week earlier), students of Group 1 solved Task 1 (Figure 6.9) where they found a recursive formula for the shape pattern they invented (Figure 6.10).

Task 1

Below you see the development of the first two shapes in a pattern.

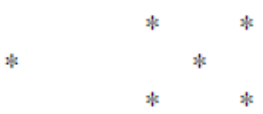

a) Draw the third and fourth shapes in this pattern. You may use the squared paper.

b) Count the number of stars in each of the shapes you have now, and put the results into a table. Explain how the number of stars increases from one shape to the next. Use this to calculate how many stars there are in the fifth shape.

c) What you have found in task b) above is called a recursive (or indirect) formula. Can you express it in terms of mathematical symbols?

Figure 6.9. Tasks 1a, 1b, and 1c



Figure 6.10. Continuation of the shape pattern in Task 1 invented by Group 1

In the following paragraphs I present the analysis of Group 1's process of finding a recursive formula for the pattern in Figure 6.10 above.

In their engagement with the pattern, the students of Group 1 have written the second through the eighth members of the sequence mapped from the shape pattern as the sum of the difference (between the current and previous members) and the previous member (reproduced in Table 6.3 on the next page). Teacher Thomas then introduces the label  $s$  with an index  $n$  where  $s_n$  represents the number of components of the  $n$ -th element. The students use this to add indexed labels to the rows of their table, as shown in Table 6.4 (on the next page).

**Table 6.3: Second through eighth member of the sequence mapped from the shape pattern in Task 1, symbolised recursively**

$$\begin{aligned} (1 \cdot 4) + 1 &= 5 \\ (2 \cdot 4) + 5 &= 13 \\ (3 \cdot 4) + 13 &= 25 \\ (4 \cdot 4) + 25 &= 41 \\ (5 \cdot 4) + 41 &= 61 \\ (6 \cdot 4) + 61 &= 85 \\ (7 \cdot 4) + 85 &= 113 \end{aligned}$$

**Table 6.4: Second through eighth member of the sequence mapped from the shape pattern in Task 1, symbolised recursively**

$$\begin{aligned} s_2 &= (1 \cdot 4) + 1 = 5 \\ s_3 &= (2 \cdot 4) + 5 = 13 \\ s_4 &= (3 \cdot 4) + 13 = 25 \\ s_5 &= (4 \cdot 4) + 25 = 41 \\ s_6 &= (5 \cdot 4) + 41 = 61 \\ s_7 &= (6 \cdot 4) + 61 = 85 \\ s_8 &= (7 \cdot 4) + 85 = 113 \end{aligned}$$

Afterwards teacher Thomas encourages them to reason algebraically by challenging them to write down  $s_{20}$ ,  $s_{43}$ , and  $s_{100}$ . This task they solve without any problems; they write the requested members of the sequence as shown in Table 6.5.

**Table 6.5: Three members of the sequence mapped from the shape pattern in Task 1, showing the relationship between consecutive members**

$$\begin{aligned} (19 \cdot 4) + s_{19} &= s_{20} \\ (42 \cdot 4) + s_{42} &= s_{43} \\ (99 \cdot 4) + s_{99} &= s_{100} \end{aligned}$$

Further, the teacher asks them what the  $n$ -th member of the sequence would look like, whereupon the students write a recurrence relation between the  $n$ -th and the  $(n - 1)$ -th members of the sequence mapped from the shape pattern in Task 1:  $(n - 1)4 + s_{n-1} = s_n$ .

With this background it may be reasonable to expect that they are aware of the syntax of a recursive formula; “previous member plus increase is equal to current member”. But during engagement with Task 3 a week later they represent a recursive formula on the form “increase is equal to current member”. There are two incidents which may explain this construal of the syntax of a recursive formula. First, there is the ra-

ther loose definition of a recursive formula in terms of the outcome of a process, as described in Task 1:

Count the number of stars in each of the shapes you have now, and put the results into a table. Explain how the number of stars increases from one shape to the next. Use this to calculate how many stars there are in the fifth shape. [Task 1b]

Second, during engagement with Task 1 (in the first lesson on shape patterns), teacher Thomas' response (turn 81 in the transcript below) reinforces focus on differences. When the students reveal that they have never heard about a recursive formula before, he explains the nature of a recursive formula like this:

81 Teacher T: *Recursive*, that is in a way, one is not so concerned with how many there are totally, but if for instance I knew that [Pause 1-3 s] if I can say, think that I know how many [components] there are in one [element], how can you tell me how I can get the number [of components] of the next? This is the recursive, you only tell how you get to the next, without considering how many [components] there are in the current.

[Task 1, Group 1]

What the teacher said in turn 81 to explain the nature of a recursive formula is comprehensive in the given context, where he made sure that they symbolised the formula adequately. In turn 81 he emphasises the nature of a recursive formula; that what is crucial to know is the difference between consecutive members of the sequence mapped from the shape pattern. He says nothing about how a recursive formula is symbolised though. As described above, a week later the students of Group 1 try to find a recursive formula for the shape pattern in Task 3: They appear to be focused on the difference between consecutive members of the sequence mapped from the shape pattern, and represent a recursive formula for the general member on the form “increase is equal to current member”. In the following paragraph I point at two circumstances that may have influenced their construal of the syntax of a recursive formula as being on this form.

It is possible that the wording of Task 1, together with the teacher's utterance, “you only tell how you get to the next, without considering how many [components] there are in the current” (turn 81), has influenced their construal of a recursive formula as being of the form “increase is equal to current element”. The fact that during engagement with Task 1 they had symbolised a recursive formula in terms of  $(n-1)4 + s_{n-1} = s_n$ , where  $s_n$  represents the  $n$ -th member of the sequence mapped from the shape pattern, seems to have no influence on their establishment of a recursive formula for the shape pattern in Task 3 a week

later. My interpretation is that the syntax of a recursive formula has not yet been adequately institutionalised.

In the next section I present the third manifestation of *Features of the milieu arising from incomplete institutionalisation of previous knowledge*.

### 6.3.3 Teacher's assumption about students' outcome from a previous lesson does not accord with achieved outcome

In this section I present the analysis of an episode which shows how teacher Erik, when he realises that the assumed outcome of a previous lesson does not accord with the achieved outcome, expounds to the students the desired knowledge.

The students of Group 1 have, during engagement with Task 3f (Figure 6.11), reasoned by naïve empiricism and found that the number of white squares in the  $n$ -th rectangle is given by  $n(n-1)$ . The teacher assumes that the students are informed by knowledge developed in the first four lessons a week earlier. Teacher Erik's utterance below (turn 693 in transcript) indicates that he expects them to have reasoned on the basis of structural relationships identified in the elements of the shape pattern in Task 3f (where the geometrical configuration of the white squares in the rectangles correspond to the triangular numbers).

Task 3 (Part II)

Below, the staircase towers have been extended into rectangles.

f) Find an explicit formula for the total number of squares in the  $n$ -th shape. Then find an explicit formula for the number of  $\square$  in the  $n$ -th shape.

Figure 6.11. Task 3f

693 Teacher E: And these are the ones, the ones we have called triangular numbers which we used last Friday as well. Those which are built up as  $1+2+3$  [points at the physical element built in centicubes by the students] and next time it is  $1+2+3+4$  (Alice: uh huh). So it is just a matter of adding numbers from one and upwards.

[Task 3 (Part I), Group 1]

However, in the first four lessons on generalisation of shape patterns students of Group 1 have not recognised or mentioned triangular num-

bers, neither have triangular numbers been mentioned by either of the teachers. Alice tells the teacher that they have not utilised structure and by this reveals that they have just generalised from examples by guess-and-check:

696 Alice: We saw it [the formula] only from examples.

[Task 3 (Part I), Group 1]

The teacher then provides an example where he illustrates a strategy for adding consecutive natural numbers:

697 Teacher E: But you have seen it on more than just examples before, I think. Because haven't you seen once that [Pause 1-3 s] what happens if I add for example,  $1 + 2 + 3 + 4 + 5$ ? [Writes in Alice's notebook] Then I can add the first [member] and the last, the second and the second last. Then I will get six each time. Then I will get two times six

698 Alice: plus three

699 Teacher E: plus three. If I have one more, I can continue and get seven

700 Alice: get seven

701 Teacher E: everywhere. How many sums which are equal to seven do I get?

702 Alice: Oh yes.

703 Teacher E: How many sums equal to seven like this do I get? That structure comes from here, a structure which I can use on all kinds of examples. If I add the first and the last [member], I always get [interrupted by Alice]

704 Alice: the last number, right

705 Teacher E: and the second and second last, I will always get one more than the amount of numbers which I am supposed to add (Alice: yes uh huh) and then I can ask how many sums equal to seven will I get? Well, indeed I will get three. And here [teacher E points at the series  $1 + 2 + 3 + 4 + 5$ ] I will get two times six. And what is the number two [*sic*]? Well, it is, it is ehm half [Pause 5 s] of this one. Here I can think of the number three as half of that one, so the formula comes from this [Pause 1-3 s] Well, no, not really. Like this, six divided by two [very low voice]. Six times seven divided by two. The number three is [the result of] six divided by two. Here [teacher E points at the series  $1 + 2 + 3 + 4 + 5$ ] it is six times [Pause 1-3 s] let us see, there it is fifteen right? [very low voice] [Sophie rolls a pen, and Ida scratches herself on the back and then looks into the ceiling] Six times five is equal to thirty divided by two is equal to fifteen [Alice nods]. Seven times six is equal to forty two divided by two is equal to [Pause 1-3 s] twenty one. This is the structure that we *have* met before and when we have done it once, we can reuse this result.

[Task 3 (Part I), Group 1]

Turn 697 and the last utterance of turn 705 indicate that the teacher considers his contribution to be reinforcement of previous institutionalisation. The dialogue shows that the teacher's explication (except for Alice's minor responses) becomes a rather long monologue. It is my interpretation that the teacher (in turn 697) has used the series  $1 + 2 + 3 + 4 + 5$  as a generic example to explain that finding the sum of the first  $n$  natural numbers is about seeing that it is possible to join pairs of numbers which adds up to the same sum: the first and the last term; the second and the second last term. Turn 705 I interpret to be an attempt from the teacher to explain that the formula for the sum of the first  $n$  natural numbers,  $\frac{n}{2}(1 + n)$ , applies also when the series has an odd number of addends.<sup>90</sup> He tries to explain how the middle term (three) of the generic series can be related to the formula which is interpreted as the sum of pairs. In his utterance, "Here I can think of the number [addend] three as half of that one", I interpret the demonstrative pronoun "that" to refer to the last addend (five) in the series. This implies that he confuses the sum of the paired terms (first and last; second and second last) with the last term of the series. He becomes aware of the mistake, corrects himself and explains three as the result of the operation "six divided by two". I interpret his low voice as indication that he is thinking, or that he is insecure about his explanation. His subsequent utterance, "Six times seven divided by two", I interpret to be his examination of the presented formula in a case when the number of addends is an even number (six).

Whereas Alice comes with some (non-substantial) responses during the teacher's explication in the transcript presented above, Sophie and Ida make some gestures (described in turn 705) which may suggest that they are not concentrating. The teacher's exposition is based on the students' recognition of triangular numbers, but because this is not a situation of recognition for the students, it is not easy for the students to fol-

---

<sup>90</sup> For a series with an even number of addends, the formula  $\frac{n}{2}(1 + n)$  can be explained by making references between the first factor ( $\frac{n}{2}$ ) and the number of pairs to be added, and between the second factor ( $1 + n$ ) and the sum of the pairs. The teacher's explication in turn 705 I interpret as a recognition that the references made above (which is a common way to rationalise the formula) do not apply directly to the case when the series consists of an odd number of addends.



low the teacher's reasoning. The teacher's point was for the students to be reminded of the structural reasoning by which the formula for the sum of the first  $n$  natural numbers (sum defined as triangular numbers) can be derived (RJ\_06.02.2004). Why this is important is not clear to Sophie who requests the point with the teacher's exposition when she asks:

708 Sophie:           What was wrong with the first one [the formula] that we made? That it wasn't [Pause 1-3 s] correct?

[Task 3 (Part II), Group 1]

As explained in Section 6.1.2, the students of Group 1 are focused on finding an algebraic expression which represents the number of white squares in the  $n$ -th rectangle in the presented shape pattern. They have found an expression which gives the expected values in several cases. The problem discovered by the teacher is that their formula is derived by empirical reasoning (guess and check), and hence, that it is not valid as a constituent in the proof of the mathematical statement in Task 3d. He does not express the reason for the insufficiency of their formula, but accomplishes spontaneously (in the moment) what he interprets as reinforcement of previous institutionalisation of the formula for the sum of the first  $n$  natural numbers. The students, however, probably experience what the teacher presents as new knowledge. The teacher of course does not have access to the students' dialogue before he joins the group, nor to any analysis of the students' engagement with the task. His response is a combination of what he observes in the moment and his own intentions for the task.

The analysis of the episode in this section provides insights into a possible effect of a feature of the milieu arising from incomplete institutionalisation of previous knowledge. The teacher develops the teaching situation in the moment as a response to the students' endeavour of which he has just been informed. This means that he probably accomplishes (or, recalls from the past) an analysis of the mathematics ( $n$ -th partial sum of an arithmetic series) simultaneously as he communicates the mathematical ideas to the students. My analysis of the didactical situation suggests that his explication is experienced by the students as insufficient. The formulae aimed at in the second part of Task 3 (the formulae for the rectangles and for the white squares) play a role in proving the mathematical statement from the first part of Task 3. Hence, these formulae must be established either by structural arguments or by reusing previous (justified) knowledge. This requirement with respect to rigor is neither expressed explicitly in the task nor by the teacher in his interaction with the students. That the students are not aware of this condition is a feature of the milieu which contributes to the students' missing comprehension of the point with the teacher's exposition of the formula for the number of white squares. In Chapter 8 I will come back to

the phenomenon of students' unawareness of the importance of how a formula is derived when I develop the analytic category, *Complexity of operating in the situation of validation*.

The analysis presented in this section has given insights into possible consequences for a teaching-learning situation when the teacher assumes learning from previous lessons which does not accord with the students' demonstrated thinking. As the observed small-group lessons were organised, without succeeding whole-class lessons, the teacher's management of subsequent lessons was dependent upon his record of students' (or groups') learning from previous lessons. It is my conjecture (which is informed by my insights from the research analysis) that the students perhaps would benefit from institutionalisation in whole class of the knowledge developed in the small-group lessons. This is not to say that I believe that students' outcome of a situation is predictable (or similar for different students) if the knowledge developed in groups has been institutionalised in whole class. An important point with institutionalisation in whole class, however, is that the teacher has a reference to which he can refer in subsequent lessons.

In the next section I give a brief summary of the findings presented in the first three sections, before I discuss the findings in Section 6.5.

## 6.4 Summary

Sections 6.1, 6.2, and 6.3 have provided insights into phenomena that constrain the feedback potential in didactical situations that aim at establishment of algebraic generality in shape patterns. The first phenomenon is conceptualised as a weakness in the objective milieu caused by the design of the tasks. It is manifested in two circumstances: in that appropriate solutions to subtasks do not prepare an adequate milieu for the teacher's intended mathematical statement; and, in that the idea of proof as designed by the teacher is not recognised by the students.

The second phenomenon which constrains the feedback potential in didactical situations is conceptualised as a weakness in the milieu caused by lack of clarification of the concepts of "mathematical statement" and "generic example". It is manifested in three circumstances: in the students' establishment of a formula for the numerical value of the general element of a shape pattern instead of a theorem about an equivalence of two expressions; in that a generic example used by the teacher is not conceived as generic by the students; and, in Topaze effects resulting from students' production of an unintended mathematical object.

The third phenomenon which constrains the feedback potential in didactical situations is conceptualised as a weakness in the milieu caused by incomplete institutionalisation of previous knowledge. It is manifested in three circumstances: in the non-reusability of knowledge

originated through a Topaze effect; in the students' establishment of a "malformula" resulting from incomplete institutionalisation of syntax of recursive formulae; and, in that the teacher's assumption about students' outcome of a previous lesson does not accord with their achieved outcome of the lesson.

The diagram in Figure 6.12 presents the analytic category developed in this chapter with its subcategories and events.

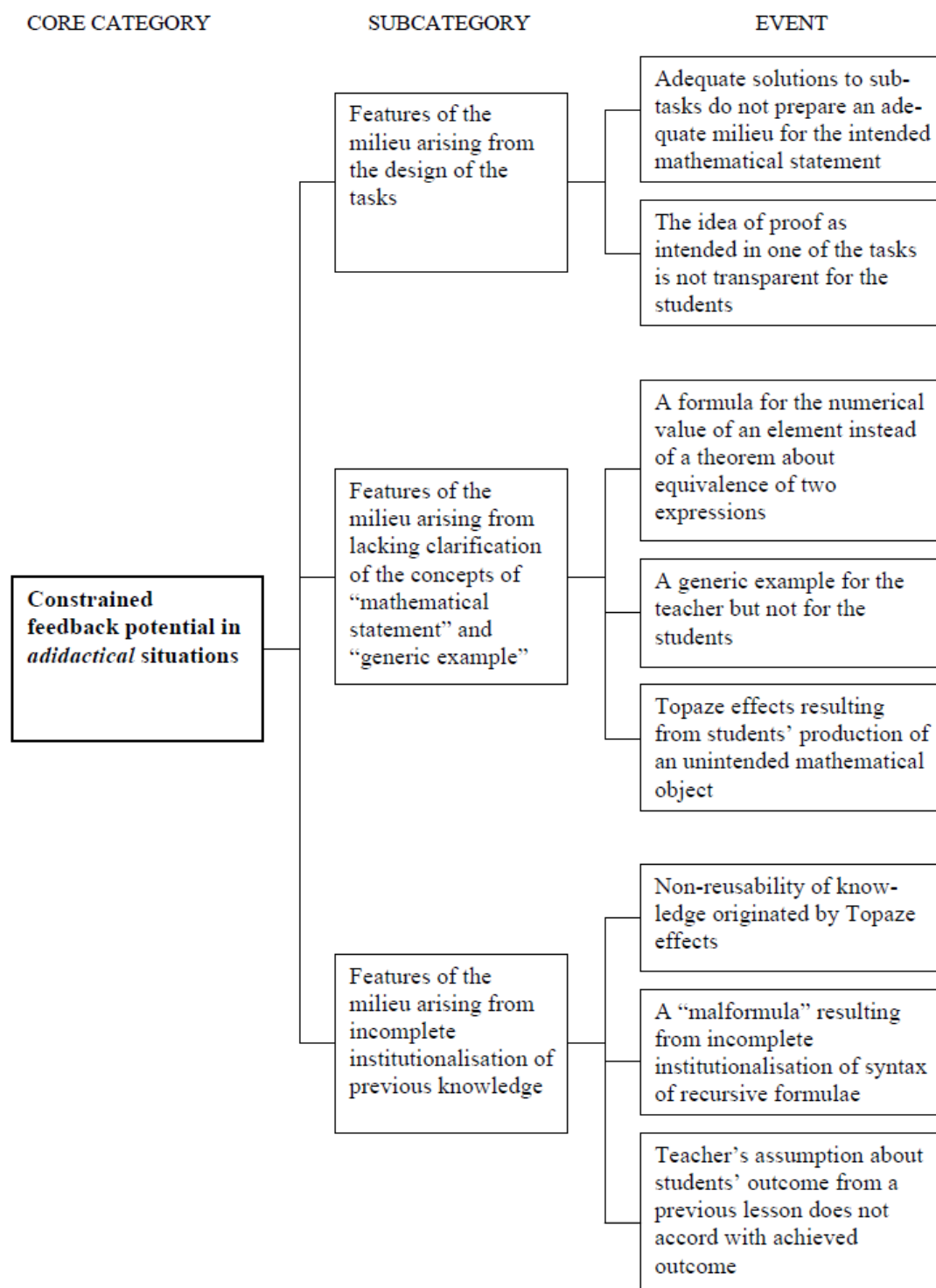

Figure 6.12. First analytic category with subcategories and events

In the next section I discuss the findings presented in this chapter.

## 6.5 Discussion of the first analytic category

The analytic category developed in this chapter, *Constrained feedback potential in didactical situations*, provides insights into factors which constrain the feedback potential in didactical situations related to students' establishment of algebraic generality in shape patterns. Constraints to the feedback potential are factors that in some way obscure, interfere or hinder the students' possibilities to produce the knowings that are crucial for the development (in the last phase, institutionalisation) of the target mathematical knowledge. The discussion of these factors is presented in three parts: design of tasks; different target mathematical objects; and, institutionalisation.

### 6.5.1 Design of tasks

The mathematical tasks with which the students engaged in algebraic generalisation of shape patterns are designed by teacher Erik for collaboration in small groups. The tasks are divided into subtasks with the intention to make the students appropriate the target knowledge which is an algebraic expression of the generality identified in the respective shape pattern. The analysis shows, however, that it is possible for the students to give appropriate solutions to the subtasks and still be kept from developing the knowledge aimed at. Hence, there is a problem with the design of the tasks; they are not focused on the target mathematical knowledge.

According to Pierre Bourdieu's principle of *economy of logic* (Bourdieu, 1980, as cited in Balacheff, 1991), students are likely to bring into play no more logic than what is necessary to solve the problem given to them. The observed students acted as practical persons, for whom the target was to produce solutions to the given tasks rather than to produce knowledge. Hence, their focus was on being efficient (practical) rather than on being rigorous (theoretical). They did one subtask at a time without reflecting on potential relationships between them or on the solutions in a broader mathematical perspective. Because this is what may be expected, it is important that mathematical tasks are designed such that responses, which might be expected according to Bourdieu's principle of economy of logic, are of a character which can afford students with knowings which can be institutionalised to become the cultural, reusable mathematical knowledge aimed at.

In the context of algebraic generalisation of shape patterns, the target knowledge is algebraic generalisation of arithmetic relations mapped from the elements of the pattern. For epistemological reasons, the focus in the tasks therefore should be on those arithmetic relations, rather than on just the total number of components of the elements. In the first parts

of the tasks with which the observed students engaged, the focus is on the total number of components of the elements (see Section 6.1.1). These tasks, in the way they focus on total number of components, are similar to tasks commonly used by mathematics teachers (and teacher educators)<sup>91</sup> to engage students in generalisation of shape patterns (e.g., Becker & Rivera, 2006; Lannin et al., 2006; Lee, 1996; Radford, 2000; Stacey, 1989). This indicates that the idea of relationships between variables is complex to communicate. I conjecture that the process of *decomposition* and the concept of *generic example*, as outlined in Chapter 5, would be useful for teachers in communicating ideas of structure and relationships between variables.

### 6.5.2 Different target mathematical objects

The epistemological analysis presented in Chapter 5 showed that the tasks with which the observed students engaged are of two different types with respect to the kind of mathematical object they aim at. Task 1, Task 2, and Task 3f aim at a formula for the general member of the sequence mapped from the respective shape pattern, whereas Task 3d and Task 4 aim at a theorem about arithmetic relations between members of particular sets of numbers (odd numbers and square numbers) arising from the respective shape pattern. The concept “formula” (recursive or explicit) is used in Task 1, Task 2, and Task 3f to refer to the target mathematical object (a functional relationship). The concept “mathematical statement” is used in Task 3d and Task 4 to refer to the target mathematical object (a theorem). The analysis presented in Section 6.2.1 showed that the concept of mathematical statement is not *a priori* knowledge for the observed students and that the concept is not clarified during the actual lesson.

The explication in Section 6.2.1 of the concepts of mathematical statement, principle, postulate, and formula demonstrated that the concepts are related in the sense that a formula is a mathematical statement in the case when it is a principle which is not self-evident, and therefore needs to be proved. The students, however, interpreted the requested mathematical statement in Task 3d to be a formula for the general member of the sequence mapped from the actual shape pattern, for which they produced the statement of a function. In Task 4, the students interpreted the requested mathematical statement to be a formula for the fifth ele-

---

<sup>91</sup> When I refer to “teachers” in general in this chapter, I include myself in the noun.

ment of the shape pattern and thereby missed the general algebraic formulation of an equivalence relation. In neither of the cases the formula established by the students satisfied the requirement of a mathematical statement. The mathematical statements aimed at were mathematical objects with the property of being equivalence relations between members of sets of numbers: Task 3d aimed at an equivalence relation between square numbers and sums of odd numbers; Task 4 aimed at an equivalence relation between square numbers and sums of triangular numbers. These equivalence relations are not self-evident and need to be proved. Hence, they are theorems according to Gowers (2008) and James and James (1992).

The students' engagement with the tasks analysed from the perspective of the target mathematical objects, leads me to suggest that it is important, in the context of generalisation of shape pattern, to distinguish between two types of outcome of algebraic generalisation. These are mathematical objects which share the property that they express arithmetic relations derived from the elements of the shape pattern. But the mathematical objects are of different nature with respect to their functional character; one is a formula in terms of an algebraic expression for the *numerical value* of the general element of a shape pattern; the other is a theorem which asserts *equality*, that is, it is a statement about equivalence of different algebraic expressions for the numerical value of the general element of a shape pattern.

The analyses of the episodes from the students' engagement with the tasks, together with the recognition that the distinction between a formula and a mathematical statement is rather sophisticated (as shown in Section 6.2.1), leads me to suggest that it is important to clarify the nature of the target mathematical object (functional relationship or theorem). Further, I conjecture that a clarification of what the requested mathematical object is intended to be *about* would make the target knowledge more accessible. That is, whether it is a formula for the general member of the sequence mapped from the shape pattern (i.e., the general member given as a function of its position), or, it is a theorem about equivalence of two different expressions for the general member of the same sequence. In other words, the target mathematical object is either a statement about a general number, or it is a statement about number theoretical relationships.

The different target mathematical objects in the context of generalisation of shape patterns have, from an epistemological perspective, different outcomes of a situation of institutionalisation. A formula for the numerical value of the general element of a shape pattern is inevitably connected to the presented shape pattern. A theorem which asserts equivalence of two different algebraic expressions mapped from a shape pattern

is, on the other hand, decontextualisable in the sense that it has relevance beyond the shape pattern from which it is derived. Institutionalisation of the knowledge in the case when algebraic generalisation aims at a formula is not institutionalisation of the formula per se, but of how it can be derived through identification of arithmetic relations mapped from the geometrical configurations and, further, generalised. The cultural, reusable knowledge in this case is the nature of the relation between the algebraic expression and its referent (a generic element). On the other hand, institutionalisation of the knowledge in the case when algebraic generalisation aims at a mathematical statement about number theoretical relationships involves decontextualisation of the mathematical statement from the shape pattern on the basis of which it is developed. The cultural, reusable knowledge in this case is generalised arithmetic relations between sequences of numbers. The mathematical statements aimed at in the analysed episodes are the following relationships: an equivalence relation between the  $n$ -th square number and the sum of the first  $n$  odd numbers (Task 3d); and, an equivalence relation between the  $n$ -th square number and the sum of the  $(n-1)$ -th and the  $n$ -th triangular numbers (Task 4).

Mathematics teachers and educators are aware that there appears to be a disjunction between the didactical intentions embedded in a designed task and the epistemological affordances when students engage with the task. My analysis presented here not only confirms this but serves to emphasise just the complexity of the didactical problem. The analysis reveal constraints at several levels, within the mathematics, the meta language used in talking about the mathematics, characteristics of the task and the outcomes that students produce from the tasks, and not least the challenge faced by teachers as they are required to react spontaneously to students with very little information about the nature of the students' engagement prior to talking with them.

What can be learned from this is that when we (mathematics teachers and educators) design tasks like this, we have to be rather cautious to ensure that the tasks are focused on the target mathematical knowledge.

### **6.5.3 Institutionalisation**

The tasks on algebraic generalisation of shape patterns were given to the students for collaborative work in small groups. There were about sixty students working in groups of three to five members. They were placed in a big classroom; the groups which I observed were placed in a separate room adjacent to the big classroom. Teaching was in the form of helping each group with the tasks, observing their work, taking part in dialogues, and assessing verbally students' solution processes and outcomes. Situations of institutionalisation related to the observed lessons took place within these meetings between the group members and the

teachers. There were no whole-class lessons taking place after the students' became engaged in groups. This means that knowings developed in the different groups were not collected, compared and brought into contact with cultural knowledge in a lesson where all students took part.

The analytic category presented in this chapter has exposed possible characteristics of the organisation of mathematics learning based exclusively on reliance on institutionalisation of knowledge in small groups. It is my conjecture that the likelihood for the teacher of discovering and adjusting shortcomings or misunderstandings caused by vague formulations in the designed tasks is less when there is no overarching institutionalisation phase. By this I mean that institutionalisation in small-groups is dependent on the teachers' observation of all groups and his record of the outcome of their work. With around 15 groups, this is challenging. Furthermore, I conjecture that the fact that there are two teachers responsible for the small-group lessons adds to the complexity of orchestrating institutionalisation of the knowings developed in the groups (with respect to coordination).

What we (mathematics teachers and teacher educators) can learn from this is that when we design teaching units that include small-group lessons, we have to attend to collection and comparison of the knowings developed in the groups. This is in order to enable the students' knowings to become cultural knowledge which they can reuse in later situations.

Chapter 6 has provided insights which constitute some answers to my research question about what factors constrain students' generalisation of algebraic generality in shape patterns. First, the design of the tasks constitutes a weakness in the objective milieu in the way solutions to sub-tasks do not prepare for the target mathematical knowledge. Second, students' unawareness of the nature of the target mathematical objects constitutes a weakness in the milieu for formulation. Third, incomplete institutionalisation of previous knowledge and inexplicit use of generic examples constitutes weaknesses in the milieu. These weaknesses constrain the feedback potential in didactical situations and thereby constitute obstacles in students' generalisation processes.

In the next chapter I present the second analytic category that emerged from the analysis. It is referred to as *Complexity of turning a situation of action into a situation of formulation*.



## 7 Complexity of turning a situation of action into a situation of formulation

In this chapter I present the second analytic category that emerged from the exploration of student teachers' collaborative work on algebraic generalisation of shape patterns. The data are analysed with the purpose of finding answers to the research question presented in Chapter 4, "What factors constrain students' appropriation of algebraic generality in shape patterns?" The analysis draws on the epistemological and didactical analyses of the mathematics potential in the tasks presented in Chapter 5. The analytic category is called *Complexity of turning a situation of action into a situation of formulation* and consists of two subcategories which are phenomena that define the category.

First, I show how recursive and explicit approaches to generality constrains the formulation phase (Section 7.1). Then, I show how inarticulate engagement with the syntax of algebra constrains the students' appropriation of algebraic generality in shape patterns (Section 7.2). Next, a summary of the findings presented in the first two sections is given (Section 7.3). The chapter closes with a discussion of the findings (Section 7.4).

### 7.1 Recursive and explicit approaches to the general member of a sequence

In this section I present the first subcategory of *Complexity of turning a situation of action into a situation of formulation*. The subcategory is concerned with how the students' generalisation processes are constrained by recursive and explicit approaches to generality. The phenomenon described by this subcategory is manifested in five different circumstances: in what I interpret as the students' overgeneralisation of a recursive approach to generality; in a Jourdain effect resulting from an attempt to establish a functional relationship; in the students' acceptance of an incomprehensible difference; in the students' and teacher's diverse foci (recursive versus explicit approaches); and, in the complexity of transforming recursive properties into an explicit algebraic expression.

#### 7.1.1 Overgeneralisation of a recursive approach to an explicit approach to generality and an incidence of a metamathematical shift

In this section I present how Group 1's engagement with an explicit formula for the general member of the sequence mapped from the shape pattern in Task 1d (Figure 7.1 on the next page) is constrained by their recent engagement with a recursive formula for the same pattern.

Task 1

Below you see the development of the first two shapes in a pattern.



- d) Try to find a connection between the position of a shape and the number of stars in that shape. This is called an explicit formula. Can you express such a formula in terms of mathematical symbols?

Figure 7.1. Task 1d

Groups 1's continuation of the shape pattern in Task 1 ("dots-at-grid" pattern) is reproduced in Figure 7.2 (it was first presented in Figure 6.10 in Section 6.3.2, but is reproduced here for the sake of continuity).

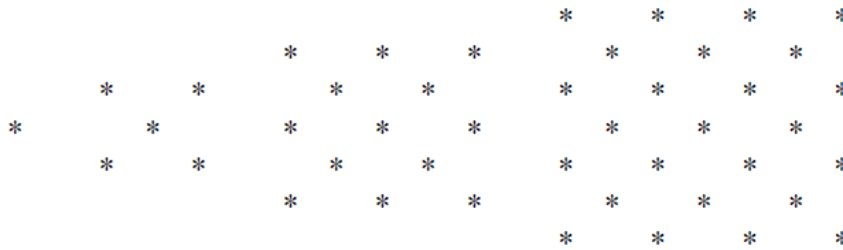

Figure 7.2. Continuation of the shape pattern in Task 1 invented by Group 1

Recall from Section 6.3.2 that during engagement with Tasks 1b and 1c, the students of Group 1 have experienced that the nature of a recursive formula for a number sequence is that it expresses the general member of the sequence as the sum of its previous member and the difference between the previous member and the current member. As explained in Section 6.3.2, the students have calculated the (first) differences between consecutive members, and have, as a result of *maieutic*<sup>92</sup> practice by teacher Thomas, represented a recursive formula as  $(n - 1) \cdot 4 + s_{n-1} = s_n$ .

---

<sup>92</sup> *Maieutics* is a method of teaching by question and answer; it was used by Socrates to elicit truths from his students (Brousseau, 1997). The method is based on the idea that truth is latent in the mind of every human being due to innate reason but has to be "given birth" by answering intelligently proposed questions.

When the students afterwards shall find an explicit formula for the  $n$ -th member of the same sequence, they use an analogue approach: In their search for an explicit relationship, explained in Task 1d as “a connection between the position of a shape and the number of building blocks in that shape”, they calculate the *differences* between the members of the actual sequence and their respective positions. This method I interpret as the students’ erroneous application of the features of a recursive approach in an explicit approach to the general member of the sequence. I conceptualise the method as “overgeneralisation” of the recursive approach.

An explicit formula for the general member of a sequence of shapes is defined as the general member expressed as a function of its position in the sequence. The method employed by the students is inappropriate because they establish an arithmetic relation (difference) between member and position,  $f(n) - n$ , instead of a functional relationship between the member and position. Based on their calculation of the differences,  $f(n) - n$ , I infer, as I reason below, that they have interpreted the word “connection” used in the task to mean “difference”. This construal done by the students may be influenced by their recent engagement with a recursive formula: In their search for a recursive formula, the students had calculated the differences between consecutive numbers of the sequence mapped from the shape pattern. The sequence of numbers they construct in search for an explicit formula is given in the second row of Table 7.1,  $f(n) - n$ .

**Table 7.1. Diagram produced by students of Group 1 in search for an explicit formula (Task 1d). The commentary column, where R refers to “row”, is made by me.**

						Commentary
1	2	3	4	5	6	R 1 $n$
0	3	10	21	36	55	R 2 $f(n) - n$
1	5	13	25	41	61	R 3 $f(n)$
	3	7	11	15	19	R 4 $(R 2)_{i+1} - (R 2)_i$
	+4	+4	+4	+4		R 5 $(R 4)_{i+1} - (R 4)_i$

The second row of Table 7.1 consists of differences between members of the sequence mapped from the shape pattern (third row) and their position (first row); these numbers are symbolised by me in the commentary column by  $f(n) - n$ . In constructing these numbers the students have not focused on coordinating the referents (stars and position) for the variables. If referents were added for numbers in the second row, the resulting

number sentence would be: 5 [stars]–2 [position?]=3 [stars]. This is problematic since the operation of difference is not referent transforming.

The students are insecure how to proceed. They continue by calculating the differences between consecutive elements of the second row of the table (first differences of  $f(n) - n$ ; written in fourth row of Table 7.1), and then the differences between these numbers again (second differences of  $f(n) - n$ ; written in fifth row). When teacher Erik, on his own initiative, enters the room, the students tell him that they have found a recursive formula and ask him if they are on the right track with respect to an explicit formula. The teacher responds by asking them what the characteristic of the recursive formula is. The students answer by describing the general nature of a recursive formula, but the teacher says that he means the particular recursive formula in Task 1. He goes on and says:

- 374 Teacher E: It is not so easy, you know, the explicit one [laughs]. There is something, there is something about the recursive [relationship] which makes it complicated [Pause 1-3 s] How is it if you look at the increase from one shape to the next?
- 375 Alice: Ehm [Pause 1-3 s] you take the previous one and multiply. No, you take the previous increase and add four to it.
- 376 Teacher E: Yes, exactly, right. You take the previous increase and add four. Uh huh.

[Task 1d, Group 1]

When the teacher in turn 374 suggests that there is something that makes the sought explicit relationship complicated, I interpret that he attempts to explain the complexity by the type of growth of the sequence arising from the shape pattern. This is indicated in the same turn by the teacher's attention to the (first) differences of the sequence when he asks the students to describe "the increase from one shape to the next". He reinforces that the growth is non-constant by repeating Alice's description of the increase; that it grows by four from one difference to the next (turn 376). I find it plausible that his claim about the complexity of the sought explicit relationship and his attention to the fact that the first differences are non-constant, are attempts to make the students work analytically and thereby potentially deduce statements about the symbolic expression of the explicit formula searched for (that it necessarily needs to include a member of second degree in the independent variable). This interpretation is consistent with a later utterance from teacher Erik, where it appears that he understands that the numbers in the fourth row represent the first differences of the sequence mapped from the shape pattern:

- 455 Teacher E: It's just that, that [Pause 1-3 s] life would have been much easier with respect to a formula, if we had a pattern where

*this* row had been a constant number. [He points at the fourth row in the table produced by the students, reproduced in Table 7.1 above]

[Task 1d, Group 1]

What I interpret as the teacher's implicit introduction of the concept of *type* of growth can be characterised as an instance of the didactical phenomenon referred to as a metamathematical shift (see Section 2.3.5). The students are given the task of finding an explicit formula for the general member of a sequence mapped from a shape pattern. They have created a table (reproduced in Table 7.1), the third row of which contains the first six members of the sequence mapped from the shape pattern,  $\{1, 5, 13, 25, 41, 61\}$ . The first five first-differences of this sequence are given by  $\{4, 8, 12, 16, 20\}$ , which should imply that the growth of the sequence be categorised as quadratic.<sup>93</sup> However, the concept of *type* of growth has not been given attention by the students. Given the school curriculum, I believe that it is most likely that the students have no previous knowledge about different types of growth of sequences. The teacher's intervention in this episode is interpreted as an instance of a metamathematical shift because the teacher does not relate his focus on growth to the symbolic expression of an explicit formula. Hence, the students are left with observations about the nature of the growth (which mathematically can be described as *quadratic*). These observations, however, are not helpful for the students in solving the original task, which is to find an explicit formula. This will be explained in the following paragraphs.

There is a general connection between a recursive and an explicit formula for a sequence of numbers which is related to the growth of the sequence: An explicit formula for the  $n$ -th element of the sequence is established by adding the first element of the sequence to the sum of the first  $(n - 1)$  first differences, as identified by the recursive formula. In the following I show that the teacher's intervention is not helpful to bring into the students' awareness a relationship between a recursive and an explicit formula.

---

<sup>93</sup> The students have not presented these first differences in Table 7.1. As explained above, they have instead calculated the differences between the numerical values and their positions.

It is possible that the students' diagram in Table 7.1 is interpreted by teacher Erik to manifest the students' work towards a recursive relationship. He never questions the relevance of the quantities in the second row. It is possible that the teacher has in mind, and responds on the basis of, a diagram with entries like the one presented in Table 7.2.<sup>94</sup>

**Table 7.2: First and second differences between numbers arising from the shape pattern in Figure 7.2.**

Numerical values of elements of pattern	1	5	13	25	41	61
First difference	4	8	12	16	20	
Second difference		4	4	4	4	

Teacher Erik challenges the students to express what the first, third, fourth and fifth rows in their diagram (Table 7.1) represent. The students claim that the first row consists of the positions of the elements of the pattern, the third row consists of the elements themselves,<sup>95</sup> the fourth row consists of the increases between the elements, and the fifth row consists of the increases of the increases of the elements.

The last concept (increase of increase) the students find a bit strange, but the teacher gives support that this is a legitimate concept. It is noticeable that he does not ask them to describe what the second row represents. A plausible explanation why he leaves this out may be that he interprets the second row to represent the differences between consecutive members of the sequence. Alice's claim about one of the numbers in the second row of Table 7.1 reinforces the conception that the second row consists of first differences:

377 Alice: Yes, and then when we, so when we found ehm we found out that the previous one was, or the difference here then (Ida: yes; Teacher E: uh huh), from the fifth to the sixth shape we have got fifty five and like this the whole way (Teacher E: uh huh). And then we have got [Pause 1-3 s]

[Task 1d, Group 1]

<sup>94</sup> Table 7.2 is made by me in an attempt to explain a plausible background for the teacher's response to the students.

<sup>95</sup> In the conversation, both the students and the teacher speak of the shapes, both when they refer to the shapes of the pattern and when they refer to the numerical values of the shapes.

But the number fifty five is *not* equal to the difference between the sixth and fifth member of the sequence mapped from the shape pattern, as Alice claims. Fifty five is equal to the difference between the sixth member and its position. Whereas Alice claims to refer to the difference  $f(6) - f(5)$  (which is equal to 20), she actually refers to the difference  $f(6) - 6$  (which is equal to 55). The question if the numbers in the second row of Table 7.1 correspond with (first) differences between consecutive members of the sequence (as, I interpret, the teacher seems to think) is not investigated.

The teacher directs attention towards the fact that the (first) difference between the members of the sequence mapped from the shape pattern is non-constant, but does not assert that the  $n$ -th first-difference can be generalised by a linear expression. Such an approach might be used if the intention were for the students to infer, from the syntax of the first differences (given by a linear expression), a consequence for the syntax of the explicit formula (that it must be a quadratic expression). Such a connection is, however, non-trivial, and I interpret the teacher's intervention in the given situation as not providing the students with necessary tools to engage with the mathematics on which the desired result depends. The teacher does not express in plain terms that he is after a connection between recursive properties of the sequence (manifested in the type of growth) and an explicit formula for the general member of the sequence. He asks the students:

474 Teacher E: Do you have a kind of feeling which type of formulaic expressions that may emerge? [Pause 16 s]

[Task 1d, Group 1]

This utterance I interpret to maintain hinting at a connection between the observations done with respect to growth and the syntax of the desired formula. There is, however, no indication in the students' reasoning which suggests that they are able to utilise the teacher's hints.

In summary, what I interpret as the teacher's focus on a connection between the nature of the growth of the sequence arising from the shape pattern and the nature of the explicit formula for the general member of this sequence can be conceptualised as an instance of a metamathematical shift. It is characterised by the phenomenon that the teacher has substituted for the mathematical task (to find an explicit formula in algebraic notation) a discussion of the logic of its solution (what can be inferred about the syntax of the explicit formula from the observations about the growth of the sequence). The teacher has tried to help the students improve their proficiency in establishing an explicit formula for the general member of a sequence, but the chosen method did not bring about the desired results.

The teacher's intervention with respect to differences did not give rise to any progress in the students' formulation of an explicit formula. He then initiates a different approach which, however, produces a Jourdain effect. This will be explained in the next section, where I present the second manifestation of *Recursive and explicit approaches to the general member of a sequence*.

### 7.1.2 A Jourdain effect resulting from an attempt to establish a functional relationship

In this section I present the analysis of the second part of Group 1's engagement with an explicit formula for the general member of the sequence mapped from the shape pattern in Task 1. The teacher suggests that the students try to look at the pattern when stars are inserted to fill the empty places in each element of the pattern they have developed (see Figure 7.2 above). Alice and Ida then find (correctly) that the members of the new sequence (with stars filled in) will be  $1^2$ ,  $3^2$ ,  $5^2$ ,  $7^2$ . When the teacher asks what kind of numbers that emerged, the following exchange takes place:

- 531 Ida: The next one is nine.  
 532 Alice: What is it called? Odd numbers?  
 533 Teacher E: Exactly, right.  
 534 Ida: But you see, that one is constant (Teacher E: uh huh).  
 535 Alice: Yes, because it is indeed a square. (Teacher E: uh huh).  
 536 Ida: So [Pause 1-3 s]  
 537 Teacher E: So now, you actually have a kind of idea about what kind of functional relationship that will, just as you said Alice, that the two [the exponent?] will become some kind of expression of second degree.<sup>96</sup>  
 538 Alice: Well, but this is only when it [the shape] is filled up with stars.

[Task 1d, Group 1]

Turns 531 and 532 show that the students focus on the bases of the powers,  $1^2$ ,  $3^2$ ,  $5^2$ ,  $7^2$ . I interpret Ida's use of the words "that one" in turn 534 to refer to the exponent of the powers. The bases of the powers vary whereas the exponent "is constant". Alice expresses the rationality of the exponent being constant because the shapes are squares (turn 535). This

---

<sup>96</sup> The teacher's turn (537) in Norwegian is: "Så da, nå har dere egentlig en slags ide om hva slags type funksjonsuttrykk som kommer, akkurat som du sa Alice, at den toeren kommer til å bli et andregradsuttrykk av et aller annet slag".



is interpreted by the teacher to mean that Alice has an idea that the “functional relationship” will be “some kind of expression of second degree” (turn 537). Alice, however, has said nothing about a functional relationship or an expression of second degree. She even repudiates that it will become a second degree expression and claims that this is only when the empty places are filled with stars (turn 538). The teacher’s judgement in 537 I interpret as an instance of the Jourdain effect; he imposes an item of scientific knowledge (a functional relationship in terms of a polynomial of degree two) in Alice’s utterance in turn 535, which actually was just about the geometric configuration of an element of the shape pattern.

Before teacher Erik leaves the students of Group 1 on their own, he encourages them to find a general expression for the number of stars which must be added to a shape in order for it to get the shape of a square. The students do not succeed in doing this and turn back to their original approach, which means to look at the difference between the members of the sequence and their positions,  $f(n) - n$ . After a while they are confused. The following utterances show that they are aware of the fact that they confuse recursive and explicit approaches to generality:

- 609 Ida:                    Because for me it is a bit confusing in a way [Pause 1-3 s]  
                                   Now I have the recursive one [leafs through her notes] in the  
                                   back of my head [interrupted by Alice]
- 610 Alice:                I don’t really manage to distinguish between [interrupted by  
                                   Ida]
- 611 Ida:                    and then I’m supposed to come up with that one [explicit]  
                                   and then I think of [Pause 1-3 s] well, maybe we’re sup-  
                                   posed to, I don’t know really, I’m all the time confused by  
                                   the one we figured out here [points at the recursive formula  
                                   in notes]
- 612 Alice:                no, because I do not have a clear distinction between recur-  
                                   sive and explicit (Ida: no). I don’t know what the different  
                                   formulae are, and then I can’t just shift from one to the oth-  
                                   er.

[Task 1d, Group 1]

There is no feedback potential in the milieu that could have prevented the students from approaching the explicit formula by the difference between member and position. The provided feedback is a definition of an explicit formula being “a connection between the position of a shape and the number of stars in that shape” (Task 1d). I believe that the students interpreted “connection” to mean “difference”, a construal probably influenced by their recent experience with a recursive formula, where difference is a key concept. I conjecture, further, that nor did the teacher realise their interpretation of the word “connection”.

I interpret the teacher's focus on the structure of the elements explained in this section as an attempt to make references between the diagrammatic configuration of a generic element and the algebraic symbols in an explicit formula; that is, between the geometric configuration of a "square" and an "algebraic expression of second degree". However, the teacher's intervention with respect to identification of reference between diagrammatic configuration of elements and algebraic symbols in a formula is characterised by his reluctance to be explicit. It appears that this reluctance, which is opening the possibility of producing a Topaze effect, results in an unhelpful lack of clarity for the students. Steinbring (2005) refers to shape patterns as geometric configurations. He asserts that they must not be seen simply as direct visual objects. Instead of being pictures or illustrations, "these geometric diagrams are carriers of multiple structures which yet have to be interpreted by the students" (Steinbring, 2005, p. 96). I conjecture that the students in the described episode would perhaps benefit from a reformulation of the task so that there were appropriate feedback that could help them interpret the multiple structures inherent in the pattern, and further, how to translate these structures into relationships represented by algebraic symbols. The didactical analysis presented in Chapter 5 provides insights into the matter of interpretation and algebraic representation of structures inherent in shape patterns.

The analyses presented in Section 7.1.1 and Section 7.1.2 shows how the students' generalisation process is constrained by vagueness in the definition of the concept "explicit formula". It is defined as a "connection between the position of a shape and the number of stars in that shape" (Task 1d). The concept *connection* is used to describe the relationship searched for. This is a spontaneous concept that lacks the scientific precision of the intended concept, *function*. The intended mathematical object is a formula for the general member of the sequence expressed as a function of its position.

The problems encountered by the students that were described in the previous and present sections produced a metamathematical shift and a Jourdain effect, respectively. The analyses of these episodes give insights into elements of importance for an appropriate milieu for algebraic generalisation of shape patterns. This issue will be discussed in Chapter 9, where I synthesise the analytic findings and discuss potential pedagogical implications.

In the next section I present the third manifestation of *Recursive and explicit approaches to the general member of a sequence*.

### 7.1.3 Acceptance of an incomprehensible difference

In this section I present the analysis which shows how students of Group 2 confuses explicit and recursive approaches to generality in Tasks 1b and 1c (Figure 7.3).

Task 1

Below you see the development of the first two shapes in a pattern.

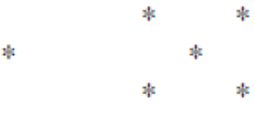

b) Count the number of stars in each of the shapes you have now, and put the results into a table. Explain how the number of stars increases from one shape to the next. Use this to calculate how many stars there are in the fifth shape.

c) What you have found in task b above is called a recursive (or indirect) formula. Can you express it in terms of mathematical symbols?

Figure 7.3. Tasks 1b and 1c

The students have identified two alternative continuations of the elements presented in Task 1: one that can be characterised as a linear pattern (reproduced in Figure 7.4 on the next page); and another that can be characterised as a quadratic pattern (reproduced in Figure 7.5 on the next page).<sup>97</sup>

I present the analysis of Group 2's engagement with the quadratic pattern.<sup>98</sup> In their search for a recursive formula for the general member of the sequence mapped from this pattern, the students have found the

---

<sup>97</sup> The students have not identified the patterns as linear and/or quadratic. These are my descriptions in accordance with different types of growth of sequences as outlined in Section 5.1 (e.g., a sequence with linear growth is mapped from a linear pattern).

<sup>98</sup> Students of Group 2 found both a recursive formula (expressed appropriately in natural language, but not in symbolic notation) and an explicit formula for the general member of the sequence mapped from the linear pattern (Figure 7.4). However, in my analysis I focus on the students' engagement with the quadratic pattern (Figure 7.5). The fact that the linear pattern was easier for these students than the quadratic pattern (in terms of success with representation of generality in algebraic notation) is consistent with Orton and Orton's (1996) findings discussed in Chapter 3 (Section 3.4), which show that linear patterns are conceived as easier for students to deal with than quadratic patterns. The reason why I focus on the alternative that is problematic for the students is due to my focus on factors that constrain students' algebraic generalisation processes.

following expression for what they believe is a recursive formula:  $a_n = n^2 + (n - 1)^2$ . This formula is, however, an explicit formula. It is developed by the students with help of the fourth element of the pattern in which the stars are painted in two colours, as shown in Figure 7.6.



Figure 7.4. One continuation of the shape pattern in Task 1 invented by Group 2 (linear pattern)



Figure 7.5. Another continuation of the shape pattern in Task 1 invented by Group 2 (quadratic pattern)



Figure 7.6. Fourth element of the quadratic shape pattern used by students of Group 2 to develop a formula (Task 1)

The students check if the conjectured formula is correct for  $n = 3$  and  $n = 5$ , and verify that the formula produces the third and fifth members in the sequence mapped from the shape pattern. Anne, however, hesitates:

- 347 Anne: and  $n^2$  well? [Pause 1-3 s]  
 348 Helen: It is correct now, isn't it?  
 349 Paul: It is in a way [Pause 1-3 s]  $(n-1)^2$  it is? [Pause 1-3 s]  
 350 Anne: Ehm?  $(n-1)^2$  is kind of what is added each time.  
 351 Paul: Yes [Pause 1-3 s]  
 352 Anne: I cannot see how  $n^2$  can be the preceding number then. Well, but [Pause 1-3 s] the answer will be correct though [laughs]. But the answer will be correct though.  
 353 Helen: It is correct for five.  
 354 Anne: Can try with six.  
 355 Paul: [indecipherable]  
 356 Anne: It is correct for six as well (Paul: uh huh) so it must be like this. But [Pause 1-3 s] it is easier to explain it with help of the shape [Figure 7.1] than thinking about those numbers (Helen: uh huh), because in my head I cannot understand that it can be right [with the numbers]. (Helen: no)

[Task 1, Group 2]

It is my interpretation that Anne understands the formula  $n^2 + (n-1)^2$  as a recurrence relation with the second term,  $(n-1)^2$ , being the first difference (turn 350). But  $(n-1)^2$  is not the difference between consecutive members of the sequence mapped from the shape pattern; it is one of the addends in the sum of consecutive squares which constitutes an explicit formula.<sup>99</sup> This is probably noticed by Anne whose utterances in turns 352 and 356 indicate that she finds it incomprehensible that  $(n-1)^2$  is “what is added each time” (in the sense of being the first difference in a recurrence relation). After this exchange Anne explains how the terms in the formula,  $a_n = n^2 + (n-1)^2$  correspond to the structure of the second and third elements in the shape pattern:

- 358 Anne: But [Pause 1-3 s] on the [second] shape you see that [Pause 1-3 s] it is one squared plus two squared [she draws a curve around the star in the middle, then draws a curve around the four stars in the next layer in the second element of the pattern] This one [about the third element] is three squared plus two squared [she connects with curves the stars that constitutes a 3x3 square, then connects the stars that constitutes a

---

<sup>99</sup> A recursive formula for the quadratic shape pattern (Figure 7.5) can be represented by  $a_n = a_{n-1} + 4(n-1)$  with initial condition  $a_1 = 1$ .

2x2 square].<sup>100</sup> (Helen: uh huh). There we see it. [Pause 1-3 s] Then I think we can continue.

[Task 1, Group 2]

The students do not discuss whether the formula is recursive or explicit, but conclude that the formula is correct. The above indicates that the students of Group 2 are not aware that they have found (a conjecture for) an explicit formula. They consider the expression  $a_n = n^2 + (n-1)^2$  to be a recursive formula. It may be that the notation they use, denoting the  $n$ -th member of the sequence mapped from the shape pattern by  $a_n$ , influences their conception of the formula as being recursive. The episode can be interpreted in terms of the didactical contract: The students' obligation according to the contract is to come up with an answer to the task which is acceptable in the classroom context. They consider it done because they have observed that the invariant structure of the shape pattern corresponds to sums of squares, represented algebraically by the formula,  $a_n = n^2 + (n-1)^2$ . Furthermore, they have verified that the conjectured formula is correct in particular cases. Anne encounters, however, a discrepancy between, on the one hand, the conception of the formula as a recurrence relation between consecutive members of the sequence mapped from the shape pattern, and, on the other hand, the conception of the term  $(n-1)^2$  as being the first difference of the mentioned sequence. That the students do not inquire into the contradiction observed by Anne can be interpreted in terms of (their interpretation of) the clauses of the didactical contract: Their obligation is not to understand the implications of a recursive (or an explicit) formula; it is to give an appropriate answer to the task set by the teacher.

In the didactical situation described in this section there is a lack of awareness of what distinguishes a recursive approach from an explicit approach to generality. The milieu for the formulation phase is therefore constrained; the students have established a formula but are not conscious of its nature. Task 1 involves establishment of, first, a recursive formula, and then an explicit formula. It is my interpretation that the students believe that they have established a recursive formula, when it is indeed an explicit one. When they later realise that what they have pro-

---

<sup>100</sup> See Figure 7.6 where the fourth element of the shape pattern is used to show that the structure of the general element is constituted from the sum of two consecutive squares.

duced,  $a_n = n^2 + (n-1)^2$ , is an explicit formula, they do not engage in reflection on what distinguishes a recursive formula from an explicit formula (nor do they engage in developing a recursive formula). The milieu does not provide the students with feedback that the formula they have developed is recursive or explicit. For instance, there is no requirement that makes it necessary for them to reflect on the nature of the formula they have established.

In the next section I show how Group 1's recursive approach to generality is left unmarked by the teacher who aims at an explicit formula. It is the fourth manifestation of *Recursive and explicit approaches to the general member of a sequence*.

#### 7.1.4 Students' recursive approach to generality unmarked by the teacher

In this section I show how the different foci (recursive and explicit approaches to generality) of Group 1 and teacher Erik constrain the situation of formulation. As explained in Section 6.1.1, the aim of Task 3d (reproduced in Figure 7.7) was for the students to express in natural language, and further, transform into algebraic notation, the mathematical statement that the sum of the first  $n$  odd numbers is equivalent to the  $n$ -th square number (RJ\_06.02.2004). The task, however, is designed such that there is flexibility with respect to the choice of approach to generality. That is, a mathematical statement induced from the shape pattern in Task 3d could be expressed as a recurrence relation: The  $n$ -th square number,  $s_n$ , is equivalent to the sum of the  $(n-1)$ -th square number and the  $n$ -th odd number ( $2n-1$ ), symbolised as  $s_n = s_{n-1} + 2n - 1$ , with initial condition  $s_1 = 1$ .

Task 3 (Part I)

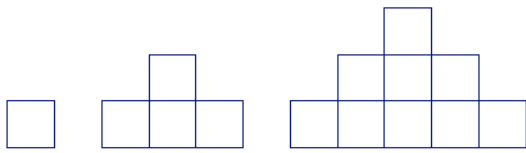

1                      2                      3

d) Can you express what the shapes seem to show, as a mathematical statement?

- In words?
- In symbols?

Figure 7.7. Task 3d

Teacher Erik was however not aware of this potential during the students' engagement with Task 3d (RJ\_06.02.2004). The milieu for the

teacher's intended mathematical statement (materialised through Task 3) is therefore not adequate. This implies a constraint to the situation of formulation.

Both groups of students have found a formula for the general member of the sequence mapped from the shape pattern in Task 3 (Part I), symbolised by  $F_n = n^2$  (Group 1) and  $a_n = n^2$  (Group 2). In presence of teacher Erik, Group 1 claims that their formula is a mathematical statement which represents what the shape pattern seems to express. The teacher then tries to encourage them to express the number of components in another way by directing their attention towards the structure of the elements of the shape pattern:

- 114 Teacher E: Then you could think, could you have expressed [Pause 1-3 s]  
115 Ida: The same thing with words?  
116 Teacher E: Well, or expressed the total number in another way, by thinking about how this shape is built up?

[Task 3 (Part I), Group 1]

The students accommodate to the teacher's request by making a recursive approach to the structure of the elements. The dialogue below shows how the students and the teacher are unaware of each other's different focus (recursive and explicit approach to generality, respectively):

- 117 Alice: It's the former plus a [Pause 1-3 s]  
118 Ida: two more on the lowest line.  
119 Teacher E: Yes it is, and when you take the former plus two more, and start by one which is on the top, what kind of numbers does emerge then?  
120 Ida: Three? [low-voiced]  
121 Sophie: Odd numbers?  
122 Teacher E: Odd numbers? Yes? One, three, five, nine  
123 Alice: seven  
124 Teacher E: well maybe seven first, yes [students laugh] uh huh [Pause 1-3 s] so that [Pause 1-3 s] uh huh [Pause 1-3 s] odd numbers that we build up, and what are we doing, and what is the result? There is a kind of connection here now. [Pause 5 s). Results in  $n$  squared, as you have said. It results in square numbers, but what do we do in order to make these square numbers appear?  
125 Sophie: What we do? We just square the shape? Or the number of the shape.  
126 Teacher E: Yes, well you do that, when you [Pause 1-3 s] but that may not be the most obvious visual picture of these towers.  
127 Sophie: That you add a line.  
128 Teacher E: Yes.  
129 Alice: That you increase at the ends with one at each side.  
130 Teacher E: Indeed.  
131 Alice: This in order to have that staircase pattern.



132 Teacher E: And then we build it line by line [Pause 1-3 s] So we are concerned with adding numbers [Pause 1-3 s] in order to get the total number of cubes [hesitantly] [Pause 1-3 s] Shape number two is one plus three [Pause 1-3 s] and the next shape is one plus three plus five [Pause 1-3 s]

[Task 3d, Group 1]

When the teacher in turn 116 challenges them to take into account how the elements of the shape pattern are built up, Alice's and Ida's responses (in the subsequent turns) indicate that they think about the recurrence relation which can be identified in the pattern. The teacher continues his attempt to make them establish an explicit relationship; that is, an equivalence relation between square numbers and the sum of odd numbers (turns 119, 124, and 126). On the teacher's request for the most obvious diagrammatic configuration of the elements, Sophie and Alice respond by describing different recurrence relations: Sophie's attention (turn 127) is on the sequence of elements (staircase towers), where the difference between consecutive members of the sequence mapped from the shape pattern is equal to an odd number. Alice's attention (turn 129), however, is on the rows of a generic staircase tower, where the difference between consecutive members of the sequence mapped from the rows of the generic staircase tower is equal to the number 2 (the rows are built up of consecutive odd numbers of cubes). Turn 132 shows that the teacher's focus continues to be on an explicit relationship (adding odd numbers and getting square numbers). Communication of the mathematics, as manifested in the excerpts from the transcript above (turns 114-132), is done in natural language. Analysis of Group 1's engagement with Task 3d shows that the situation of formulation is constrained by the complexity of expressing in natural language, reference between the position and numerical value of elements in the shape pattern. This is reported in Måsøval (2006). It is my conjecture that it perhaps would be easier for the teacher to discover the students' recursive approach if the mathematics were communicated in algebraic notation.

The missing coordination of the teacher's and the students' approaches contributed to production of Topaze effects and Jourdain effects, the analysis of which was presented in Section 6.2.3. The fact that a mathematical statement in Task 3d can be given either as a direct relationship or as an indirect relationship is not *per se* detrimental to the situation of formulation. It is my interpretation that it is the interlocutors' apparent lacking awareness (in the given situation) of the two alternatives which constrains the situation of formulation.

The analysis presented in this section has shown how the different foci of the teacher and the students constrain the situation of formulation. Teacher Erik has defined the target knowledge of Task 3 to be a mathe-

mathematical statement in terms of an equality: the statement of equivalence between square numbers and sums of odd numbers. The milieu, however, is not consistent with the intended goal. This is manifested in the possibility of formulating a mathematical statement in terms of a recurrence relation between a square number and the sum of the previous square number and an odd number, which is also an equivalence relation. The former mathematical statement (“the sum of the first  $n$  odd numbers is equivalent to the  $n$ -th square number”) is the outcome of an explicit approach whereas the latter (“the  $n$ -th square number is equivalent to the sum of the  $(n - 1)$ -th square number and the  $n$ -th odd number”) is the outcome of a recursive approach to generality. Both statements have the quality of being equivalence relations between sets of numbers (square numbers and sums of odd numbers).

In the next section I present the analysis of the complexity experienced by the students when they attempt to transform recursively expressed properties into an expression in closed form. It is the fifth manifestation of *Recursive and explicit approaches to the general member of a sequence*.

### 7.1.5 Complexity of transforming recursively expressed properties into an explicit algebraic expression

During their engagement with Task 3, the students of Group 1 are given the task of transforming from natural language into mathematical symbols the mathematical statement that “the sum of the first  $n$  odd numbers is equal to the  $n$ -th square number”. The teacher writes down, in mathematical symbols, the statement in two particular cases (when  $n = 2$  and  $n = 3$ ), before he writes down the general equivalence relation,  $1 + 3 + 5 + \dots + \text{L} + \text{ } = n^2$ , where he leaves open space for the symbolic expression for the  $n$ -th odd number (the equalities are reproduced in Table 7.3). He then gives the students the task of finding a symbolic expression for the  $n$ -th odd number:

158 Teacher E: This is square number two. (Alice: uh huh). If I take the first three [he writes  $1 + 3 + 5 = 9 = 3^2$ ] I will come up with square number three, and so on. Then I take the first  $n$  ones, but how shall I give the message about this? Then I continue here and I shall go up to odd number  $n$ . How shall I express odd number  $n$ ?

[Task 3d, Group 1]

The excerpt from the dialogue below makes evident the problem of choosing and remaining faithful to a point of reference when representing a quantity (the  $n$ -th odd number) by an explicit algebraic expression. This problem is described by Radford (2000) as the *positioning problem*, and is about how the rank of a member in a sequence relates to the member itself.

**Table 7.3. The equivalence relations in two particular cases and in the general case, as written by teacher Erik in Alice’s notebook**

$1 + 3 = 2^2$
$1 + 3 + 5 = 3^2$
$1 + 3 + 5 + L + \dots = n^2$

- 159 Sophie: Can’t we just take  $n$ ? [for the  $n$ -th odd number]
- 160 Teacher E: What is the fourth odd number?
- 161 Alice: 7.
- 162 Teacher E: The fifth odd number?
- 163 Alice?: 9.
- 164 Teacher E: So odd number  $n$  is? [Pause 1-3 s]
- 165 Ida:  $n + 2$ ?
- 166 Teacher E: Well, but it is exactly a structure like this you have to try to search for now. Odd number  $n$  cannot be  $n$ , because then odd number four would have been four. If you say  $n$  twice in a sentence, it has the same meaning. [Pause 5 s]
- 167 Ida: But it has to be something with plus two (Teacher E: ok?) because it increases by two each time.
- 168 Teacher E: Yes, but then you are on a path in a way, which is about searching, searching for a structure. Then you can start to test out. You [to Ida] have an idea that it is  $n$  plus two.
- 169 Alice: If we take five here then, so the increase from here to there is nine. [She points with her pencil at something she has written in her notebook]
- 170 Ida: What? [Sophie draws her eyebrows together]
- 171 Alice: Do you get four plus two then? [Pause 1-3 s] Is it?
- 172 Ida: I don’t know, you have to bring all this matter [about the sum of the odd numbers?] with you. That’s what I mean. I don’t know. I only [interrupted by Alice]
- 173 Alice: If we’re going to find the [indecipherable] number four. [Teacher E leaves the group room]
- 174 Ida: know that it increases by two each time. But how shall we write it? I don’t know.

[Task 3d, Group 1]

Sophie’s suggestion in turn 159 that they let  $n$  represent the  $n$ -th odd number illustrates that she does not relate the rank of the member to the member itself. The impossibility of Sophie’s suggestion is demonstrated by the counterexamples provided in turns 160 – 163. Ida’s suggestion to let the  $n$ -th odd number be represented by  $n + 2$  (turn 165) she supports by the claim that “it has to be something with plus two because it increases by two each time (turn 167). Moreover, nor does the expression  $n + 2$  relate the rank of the member to the member itself. I interpret the expressions  $n$  and  $n + 2$  in Sophie and Ida’s suggestions to be what Radford (2002a) refers to as *symbolic narratives*, where  $n$  and  $n + 2$  are

*nouns* in a referencing act (Radford, 2002b). What makes  $n$  and  $n + 2$  symbolic narratives is that these “translations” still tell a story, not in natural language, but in mathematical symbols. The expression  $n$  tells that it is the  $n$ -th member, whereas  $n + 2$  tells the story that the difference between two consecutive members in the sequence of odd numbers is equal to 2. “Adding two” describes the recursive relationship between consecutive members of the sequence of odd numbers. What is desired, however, is an explicit relationship that expresses the  $n$ -th odd number as a function of its rank.

The teacher has reformulated the task; the original task (to express in terms of a mathematical statement what the shape pattern seems to show) is reduced to finding a symbolic expression for the  $n$ -th odd number. But the requirement that the expression needs to be *explicit* (i.e., in closed form) remains implicit (the expression aimed at is the  $n$ -th term of the sum at the left hand side of the equality  $1 + 3 + 5 + \dots + \dots = n^2$ ). The new task is formulated by the teacher under the constraint that the  $n$ -th odd number is an addend in an explicit formula; therefore the  $n$ -th odd number needs to be represented in closed form. This may explain why the teacher did not choose to build on the students’ contributions about adding 2 and then help them with notation that could have enabled them to establish a recurrence relation ( $u_n = u_{n-1} + 2$  as mentioned above).

The target knowledge intended by the teacher (an equivalence relation between square numbers and sums of odd numbers) disappears as a consequence of the reformulation of the task, which is a characteristic of the Topaze effect. The reformulated task is not devolved to the students as an appropriate didactical situation. These students have limited experience with representing recurrence relations in mathematical symbols. They have solved Task 1 one week earlier, where they have found a recursive formula for the general member of the sequence mapped from the shape pattern. However, as explained in Section 6.3, there has been an incomplete institutionalisation of representation of recursive formulae.

Another incidence of complexity related to transformation of recursively expressed properties into an explicit algebraic expression occurs when Group 2 is working on the pattern of rectangles in Task 3f (Figure 7.8 on the next page). Turn 127 in the transcript shows how Anne uses empirical examples and makes a claim about the growth of the sides of the rectangles:

127 Anne: Two times three, three times five, four times seven. So the width increases by one and the length increases by two.

[Task 3f, Group 2]

Task 3 (Part II)

Below, the staircase towers have been extended into rectangles.



- f) Find an explicit formula for the total number of squares in the  $n$ -th shape. Then find an explicit formula for the number of  $\square$  in the  $n$ -th shape.

Figure 7.8. Task 3f

Both Anne and Helen write in their notebooks a table of products of two factors (reproduced in Table 7.4) which represent the width and length of rectangles in the pattern of rectangles. Helen proposes that the second factor, which represents the length of the  $n$ -th rectangle, is symbolised by  $n + 2$  (turn 138 in the transcript):

136 Helen: Shall we write it as a formula then?

137 Anne:  $a_n$  is equal to [Pause 1-3 s]  $n$  times [Pause 1-3 s]

138 Helen:  $n$  times [Pause 1-3 s] times  $n$  minus, no  $n$  plus two.

[Task 3f, Group 2]

Table 7.4. Area of rectangles in a shape pattern written as the product of width and length (Task 3f)

$a_1 = 1 \cdot 1$
$a_2 = 2 \cdot 3$
$a_3 = 3 \cdot 5$
$a_4 = 4 \cdot 7$
$a_5 = 5 \cdot$

Helen's suggested expression for the width of the general rectangle is similar to Ida's suggested expression for the  $n$ -th odd number (as discussed above) in the sense that it does not relate the rank of the general

rectangle to its measured length.<sup>101</sup> It can therefore be interpreted as a symbolic narrative, a noun in a referencing act (Radford, 2002a, 2002b).

In Section 7.1.4 I explained how Group 1's recursive approach to generality was not noticed by the teacher. An important factor in explaining that phenomenon was the students' lacking proficiency in notation for recurrence relations. Lacking proficiency in notation is also an important factor in explaining the complexity experienced by the students in transforming verbally expressed recursive properties into explicit expressions, analysed in this section.

The analysis presented in Sections 7.1.1 – 7.1.5 has shown how confusion of recursive and explicit approaches to generality in shape patterns contributes to the complexity of turning a situation of action into a situation of formulation.

In the next section I present the second subcategory of *Complexity of turning a situation of action into a situation of formulation*.

## 7.2 The syntax of algebra

The second subcategory of *Complexity of turning a situation of action into a situation of formulation* is concerned with how expectations in the milieu with respect to type of formula combined with students' limited knowledge of syntax of formulae constrain the situation of formulation. The subcategory is manifested in two circumstances: in identification of a need for knowledge of arithmetic series; and, in the students' regard (or as I will argue, disregard) of a presented formula.

### 7.2.1 Identification of need for knowledge of arithmetic series

In search for an explicit formula for the general member of the sequence mapped from the “dots-at-grid” pattern (repeated in Figure 7.9 on the next page), the students of Group 1 have written each of the first nine members of the sequence as the sum of the previous member plus the difference (with  $s_1 = 1$ ).

---

<sup>101</sup> The positioning problem is however solved for the first factor of the products which represent the area of the rectangles in the pattern of rectangles. The rank of a rectangle is equal to its measured width.



Figure 7.9. “Dots-at-grid” pattern derived from Task 1 invented by Group 1

Further, they have written the members of the sequence as sums of differences according to the recurrence relation (see Table 7.5), and identified that the first differences are numbers in the four-times table.

Teacher Thomas has helped them to focus on the number theoretical properties of the resulting sums as being one more than a number in the four-times table (written at the left column of Table 7.5). They have expressed the third, fourth, fifth, sixth and seventh element as one more than a multiple of four when Ida identifies the regularity as expressed in the utterance below:

758 Ida:                    yes [Pause 1-3 s] three, six, ten [whispers] [Pause 6 s] Yes, I know! It increases by one each time [she points at the factors 3, 6, 10, 15, 21]. If you start with three, three plus three is equal to six. Six plus four is equal to ten. Ten plus five is equal to fifteen. Fifteen plus six is equal to twenty one.

[Task 1, Group 1]

**Table 7.5. The first nine members of the sequence mapped from the shape pattern in Task 1 as developed by students of Group 1**

$(4 \cdot 0) + 1$	$s_1 = 1$
$(4 \cdot 1) + 1$	$s_1 + 4 = s_2 = 5 = 1 + 4$
$(4 \cdot 3) + 1$	$s_3 = s_2 + 8 = 1 + 4 + 8 = 13$
$(4 \cdot 6) + 1$	$s_4 = s_3 + 12 = 1 + 4 + 8 + 12 = 25$
$(4 \cdot 10) + 1$	$s_5 = s_4 + 16 = 1 + 4 + 8 + 12 + 16 = 41$
$(4 \cdot 15) + 1$	$s_6 = s_5 + 20 = 1 + 4 + 8 + 12 + 16 + 20 = 61$
$(4 \cdot 21) + 1$	$s_7 = s_6 + 24 = 1 + 4 + 8 + 12 + 16 + 20 + 24 = 85$
$(4 \cdot 28) + 1$	$s_8 = s_7 + 28 = 1 + 4 + 8 + 12 + 16 + 20 + 24 + 28 = 113$
$(4 \cdot 36) + 1$	$s_9 = s_8 + 32 = 1 + 4 + 8 + 12 + 16 + 20 + 24 + 28 + 32 = 145$

Ida talks about the difference between the multipliers of four when she says that “it increases by one each time”. The students consider the expressions at the left hand side in Table 7.5 and try to find a connection between the position (number of row) of an expression and the number

by which four is multiplied, expressed by the teacher as “a connection between the index and the number by which we multiply four” (turn 818). They do not succeed in doing so, and are encouraged by teacher Thomas to look at the structure of the elements of the shape pattern (by filling in stars at the open spaces to create squares and keep track of the open spaces in order to subtract afterwards).

The students find, as a result of engagement with filling in and subtracting stars on shapes drawn in their notepads, that the second, third, and fifth elements of the sequence can be expressed as  $3^2 - 2 \cdot 1 - 1 \cdot 2$ ,  $5^2 - 3 \cdot 2 - 2 \cdot 3$ , and  $9^2 - 5 \cdot 4 - 4 \cdot 5$ , respectively. They then conjecture that the sixth element can be expressed as  $11^2 - 6 \cdot 5 - 5 \cdot 6$ , which indicates that they have identified the invariant structure of the first three examples. The lesson ends however before they are given the opportunity to generalise algebraically the particular observations expressed as arithmetic relations.

The arithmetic relations manifested in Table 7.5 (on the previous page) can be generalised in algebraic notation in terms of

$$s_n = 1 + 4 + 8 + 12 + L + 4(n - 1) = 1 + 4(1 + 2 + 3 + L + n - 1) = 1 + 4T_{n-1},$$

where  $T_n = 1 + 2 + 3 + L + n$  is defined as the  $n$ -th triangular number. In a conversation with the two teachers after the lesson (RJ\_30.01.2004), teacher Erik (who had designed the tasks) told that he had expected that the students would recognise the triangular numbers, and hence, that

they could use the formula,  $T_n = 1 + 2 + 3 + L + n = \frac{n(n+1)}{2}$  to express

the general element of the identified pattern. Teacher Thomas said that he, like the students, had not recognised the triangular numbers.

In looking back on the students’ engagement, it can be noticed that they do not generalise the expressions written as sums of multiples of four. Nor does teacher Thomas encourage them to do so. From their diagram (Table 7.5 above), it would be possible to express the elements as shown in Table 7.6. The  $n$ -th element could then be represented by  $s_n = 1 + 1 \cdot 4 + 2 \cdot 4 + 3 \cdot 4 + L + (n - 1)4 = 1 + 4(1 + 2 + 3 + L + n - 1)$ .

**Table 7.6. Representation of elements as potential basis for generalisation**

$s_1 = 1$ $s_2 = s_1 + 4 = s_1 + 1 \cdot 4$ $s_3 = s_2 + 8 = s_2 + 2 \cdot 4 = 1 + 1 \cdot 4 + 2 \cdot 4$ $s_4 = s_3 + 12 = s_3 + 3 \cdot 4 = 1 + 1 \cdot 4 + 2 \cdot 4 + 3 \cdot 4$ etc.
---



Whether the indeterminate expression for  $s_n$  would count as an answer in the classroom context is not clear from the task. There is no feedback potential in the didactical situation that could give validity to the expression; the only thing asked for in Task 1d is an explicit formula for the “connection between the position of a shape and the number of stars in that shape”. The member  $s_n$  is equivalent to the  $n$ -th partial sum of an arithmetic series with difference four. Hence, the expression can be simplified as  $s_n = 1 + \frac{n-1}{2}[4 + 4(n-1)] = 2n^2 - 2n + 1$ . But knowledge of sums of arithmetic series is not expected prior knowledge for these students. Therefore, the indeterminate expression (the series)  $s_n = 1 + 1 \cdot 4 + 2 \cdot 4 + 3 \cdot 4 + \dots + (n-1)4 = 1 + 4(1 + 2 + 3 + \dots + n-1)$  would be an acceptable formula in mathematical symbols for the general element of the sequence mapped from the shape pattern.

It is interesting that, when the students have found expressions for  $s_1, s_2, s_3, s_4, s_5$ , and  $s_6$  (reproduced in Table 7.7), the following exchange takes place:

- 690 Alice: We are indeed writing down the whole four-times table here.  
 691 Ida: Can't we rather write [Pause 8 s]  
 692 Alice: Just write  $s_7$  as well.  
 693 Ida: I thought if we could find a [Pause 1-3 s] symbol for that? [She points at the right hand side of the diagram where the elements are expressed as sums: one plus four plus eight plus twelve, etc.]

[Task 1, Group 1]

Ida's request for a symbol to represent the sum (turn 693) could have been met by knowledge of arithmetic series, as explained above.

**Table 7.7. The diagram produced by students of Group 1**

$s_1 = 1$
$s_1 + 4 = s_2 = 5 = 1 + 4$
$s_3 = s_2 + 8 = 1 + 4 + 8$
$s_4 = s_3 + 12 = 1 + 4 + 8 + 12$
$s_5 = s_4 + 16 = 1 + 4 + 8 + 12 + 16$
$s_6 = s_5 + 20 = 1 + 4 + 8 + 12 + 16 + 20$

This episode points at generalisation of shape patterns as a context which can motivate for learning about series. It is, however, likely that the students would not have considered the indeterminate expression  $s_n = 1 + 4(1 + 2 + 3 + \dots + n-1)$  to be an adequate formula. This claim I

will support by the analysis in the next section, where I present the second manifestation of *The syntax of algebra*.

### 7.2.2 Disregard of a presented formula associated with limited knowledge of syntax of formulae

During their engagement with Task 3d, the students of Group 1 are, as explained in Section 7.1.5, given the task of transforming from natural language into mathematical symbols the mathematical statement that “the sum of the first  $n$  odd numbers is equal to the  $n$ -th square number”. The teacher has presented the conjecture in the general case,  $1+3+5+\dots+n = n^2$ , and has challenged the students to represent in mathematical symbols the  $n$ -th odd number (which is omitted in the presented equality). The students do not succeed in symbolising the  $n$ -th odd number, and start to focus on the increase from the  $(n-1)$ -th member to the  $n$ -th member of the sequence. They find out that the increase is given by  $n+(n-1)$ , but are not aware of the fact that this expression indeed represents the  $n$ -th odd number. They conjecture that the formula which describes the pattern in Task 3 (Part I) is given by  $n+(n-1) = n^2$ . The students refer to the formula as a “two-in-one formula”, because it tells them both the increase from one member to the next (left hand side of conjectured formula) and how many cubes there are totally in the  $n$ -th shape (right hand side of conjectured formula). However, they find that it cannot be correct since the two sides give different values when evaluating for particular values of  $n$ . They conclude that the failure with their formula is that it says nothing about adding odd numbers.

I notice that the students of Group 1 do not consider the teacher’s conjectured formula,  $1+3+5+\dots+n = n^2$ , as relevant. The conjecture presented by the teacher is about adding odd numbers and, hence, what is omitted (the  $n$ -th odd number) is exactly the increase from the  $(n-1)$ -th member to the  $n$ -th member of the sequence. Alice has even written the third and fourth row in the diagram with which the teacher started (as shown in Table 7.8).

**Table 7.8: Diagram showing arithmetic relations between odd numbers and square numbers (the third and fourth rows are written by Alice, the others by teacher Erik)**

$1+3 = 2^2$
$1+3+5 = 3^2$
$1+3+5+7 = 4^2$
$1+3+5+7+9 = 5^2$
$1+3+5+\dots+n = n^2$

But the students do not consider the indefinite expression with dots to be an adequate mathematical formula. Evidence for this claim is provided by the transcript below:

- 360 Teacher E: If we add them, we will get square number four [Ida nods] which is sixteen. Here we have the first odd number, the second, the third, the fourth, the fifth. [He points at the fourth row] If we add them all, then we will get the fifth square number. And how do we get the  $n$ -th square number? Then we must add all the odd numbers from the bottom [interrupted by Ida]
- 361 Ida: And how shall we write it then?
- 362 Teacher E: and up to the  $n$ -th odd number of which you have now got an expression, which is two  $n$  minus one [Pause 1-3 s] So, I don't know if you perhaps [Pause 1-3 s] think that this becomes more complicated than it really is? But actually [he writes  $2n - 1$  as the last addend of the sum at the left hand side of the equality at the bottom row, so that it becomes  $1 + 3 + 5 + \dots + 2n - 1 = n^2$ ] like this, that we can mark that we have added (Alice: uh huh) the first, the second, the third odd number up to the  $n$ -th odd number. That is the process of building with cubes. The first odd number, the second odd number and so forth, like this. Here it is concretised. [He picks up a tower that the students have built with centicubes, the image of which is shown in Figure 7.10 on the next page]
- 363 Teacher E: Here is the left hand side of that equation. [He moves the pen alongside the equality  $1 + 3 + 5 + \dots + 2n - 1 = n^2$ ]
- 364 Alice: Right.
- 365 Ida: Right.
- 366 Teacher E: The first odd number [he points at the first addend at the left hand side of the equality and thereafter at the first [top] row in the tower] plus the third odd number. [He points at the second row in the tower] Then we have joined [interrupted by Alice]
- 367 Alice: The second odd number you mean.
- 368 Teacher E: The second odd number I mean, hence I have joined that one. (Ida: uh huh). Plus the third odd number, then I have joined that one [he points at the third row in the tower] plus the fourth odd number and then we can think that it will continue [Pause 1-3 s]
- 369 Ida: Yes, but how shall, shall I kind of write [Pause 1-3 s]
- 370 Teacher E: There are not so many other ways to do it, actually. Well, there is another way, but [laughs a bit]. But for the time being you can write it like this, plus and then dot dot dot, to indicate that there is (Ida: yes) much in between.
- 371 Ida: It continues the same way?
- 373 Teacher E: Continues the same way up to the  $n$ -th odd number. (Ida: yes). And then it adds up to the  $n$ -th square number.
- 374 Alice: Is this a [Pause 1-3 s] formula?

- 375 Teacher E: *This* is a formula.  
 376 Alice: I didn't expect that we should include so much [Pause 1-3 s]  
 377 Teacher E: No, I see.  
 378 Ida: But, you remember in the textbooks in secondary school? First there was an explanation, and afterwards they only used [Pause 1-3 s] (Alice: yes, but)  $n$  squared [Pause 1-3 s] or two  $n$  minus one.  
 379 Alice: Yes, because a formula [Pause 1-3 s] that is kind of not any number [smiles].  
 380 Ida: Yes, I know [smiles].  
 [Task 3, Group 1]

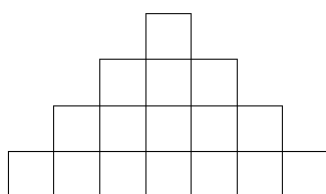

Figure 7.10. Image of the tower built in centicubes by students of Group 1

The problem for the students is how to write in mathematical symbols the general case where there is a variable number of odd numbers to be added (Ida in turns 361 and 369). The teacher writes  $2n - 1$  as the last addend of the sum at the left hand side of the equivalence relation that he had written down the last time he visited the group, so it becomes  $1 + 3 + 5 + \dots + 2n - 1 = n^2$ . His question in turn 362, if they happen to think that the formula becomes more complicated than it really is, possibly indicates that he is not aware of what they find problematic. He then explains carefully, with reference to the fourth staircase tower built in centicubes (which they have in front of them), how the process of constructing a tower with rows of (odd number of) cubes is interpreted arithmetically as adding odd numbers (turns 362, 363, 366, and 368).

Ida's question in turn 369 appears to be motivated by the teacher's description of the general case: "... then we can think that it will continue" (teacher E in turn 368). This possibly indicates that she does not know how to represent mathematically that the process of adding odd numbers will *continue* up to an indeterminate odd number. Hence, there is a problem with the syntax. Alice's question in turn 374 provides evidence that she has not considered the teacher's equivalence relation to qualify as a formula. Her explanation (turn 376) why this has been the case is supported by Ida (turn 378) who refers to secondary school textbooks. It is my interpretation of turns 376, 378 and 379 that Alice and Ida think that mathematical formulae should be simple expressions in terms of  $n$  and not a sum of several numbers.

Turns 369 – 380 indicate that the expression at the left hand side of the equality  $1 + 3 + 5 + \dots + 2n - 1 = n^2$  is unfamiliar for the students and is conceived of as non-adequate because it consists of an indeterminate sum of several numbers in addition to an algebraic expression. They have been searching for a simple (determinate) expression in terms of  $n$ , a closed formula that would represent an indeterminate sum of odd numbers. I interpret the students' conjectured formula, the expression  $n + (n - 1) = n^2$ , to be the result of their attempt to represent the requested mathematical statement by a recursive formula.

As explained in Section 7.1.4, Task 3d is designed in a way that does not exclude a mathematical statement in terms of a recursive relationship. That the students struggle with representing the mathematical statement recursively, I ascribe to their limited experience with notation for recursive relationships. Their disregard of the explicit formula presented to them by the teacher may be the result of limited knowledge of syntax of explicit formulae; an indeterminate expression was not judged adequate by the students. These phenomena constitute shortcomings in the milieu for formulation of algebraic generality in shape pattern and points at the importance of students' familiarity with symbolisation of number theoretical relationships.

The analysis presented in this section points at the necessity an *a priori* justification of the kind of interaction with the milieu which is necessary in order to develop particular forms of knowledge. To develop a recursive formula requires different interaction with the milieu (including notation) than an explicit formula requires. The analysis presented shows how inexplicit expectations with respect to type of formulae together with students' limited experience with the syntax of algebra constitute shortcomings in the milieu for formulation of a mathematical statement.

In the next section I present the third manifestation of *The syntax of algebra*.

### **7.2.3 Complicated symbolisation of relations between natural numbers, odd numbers and square numbers**

The tasks on algebraic generalisation of shape patterns given to the students are of two kinds: The patterns in Task 1, Task 2, and Task 3 (Part II) call for formulae for the numerical value of the general element of the sequence of shapes. The patterns in Task 3 (Part I) and Task 4, on the other hand, call for mathematical statements about number theoretical relationships (that is, equivalence relations between sets of numbers): The pattern in Task 3 (Part I) is intended to illustrate that the sum of the first  $n$  odd numbers is equivalent to the  $n$ -th square number. The pattern in Task 4 is intended to illustrate that the sum of the  $(n - 1)$ -th and the  $n$ -

th triangular numbers is equivalent to the  $n$ -th square number. In this section I present the analysis of the complexity experienced by Group 1 of symbolising algebraically the arithmetic relation between the  $n$ -th square number and the sum of the first  $n$  odd numbers, as intended illustrated in the shape pattern in Task 3 (Part I).

As explained in Section 6.2.1, the students of Group 1 have during engagement with the first part of Task 3 established a formula for the numerical value of the general element of the shape pattern (represented by the function  $F_n = n^2$ ). This is, as argued in Section 6.2.1, not the mathematical object aimed at. When the teacher observes that they have made the statement of function, he challenges them to express the numerical value of the general element of the shape pattern in a way that says something about how this element is built up. Section 6.2.3 presented the analysis of how this situation produces Topaze and Jourdain effects. Teacher Erik has conveyed, in natural language, that the mathematical statement aimed at asserts that the sum of the first  $n$  odd numbers is equal to the  $n$ -th square number. He then challenges them to write the statement in mathematical symbols:

152 Teacher E: Because what we have expressed now with words, is in a way an equation, that if we add the first  $n$  odd numbers, we'll get the  $n$ -th square number. And with symbols,  $n$  squared will denote square number  $n$ , so that is what we *get at*. But then you can start to think about, how can we, how can we, with symbols, write with symbols that we add the first  $n$  odd numbers? [Pause 5 s]

[Task 3, Group 1]

As explained in Section 6.3.1, teacher Erik has, further, illustrated the mathematical statement in two particular cases (for  $n = 2$  and  $n = 3$ ) and in the general case where he has omitted the representation of the  $n$ -th odd number (see Table 7.8 in the previous section). The students struggle for about 10 minutes to find out how to symbolise the  $n$ -th odd number, but do not succeed. Alice and Ida reveal that they know that the amount of odd numbers to be added is equal to the rank of the square number:

193 Alice: Here you have four, the first four odd numbers, and the answer will be four squared, right? And the next

194 Ida: There it will be twenty five, you add five numbers. But how do you say it?

[Task 3, Group 1]

But they do not know how to symbolise it, expressed as not knowing “how to say it”.

195 Alice: How do you say it?

196 Ida: How do you say that these five numbers becomes a five. Because that one is ok. [She points at the right hand side of the expression] We know how we shall write that one. It is  $n$

squared. But how do you say those? [about the left hand side of the expression] Ok, what is  $n$  then?

[Task 3, Group 1]

This I interpret as problems with the relations between  $n$ , the  $n$ -th odd number and  $n$  squared. The mathematical statement aimed at in this case is, as commented by teacher Erik in turn 152 above, a mathematical statement about equivalence of two quantities; that is, an equality. The statement of equality of two different expressions (here,  $1 + 3 + 5 + \dots + 2n - 1$  and  $n^2$ ) for the numerical value of the general element of a shape pattern is a mathematical object of a different nature than a formula for the general member of the sequence of numbers arising from the shape pattern. In the first case, the mathematical object is a mathematical statement about arithmetic relations between members of sequences of numbers (here, odd numbers and square numbers); in the second case, the mathematical object is a functional relationship between position and member of the sequence arising from the shape pattern.

As explained in the previous section, the students disregard the equivalence relation presented by the teacher as a consequence of limited knowledge of syntax of mathematical formulae. It may be that the students' problems with symbolising what they have expressed correctly in natural language (turns 193 – 196) is based on a conception that it should be possible to represent the observed arithmetic relation between odd numbers and square numbers in terms of a formula as they had done in Task 1.<sup>102</sup> But in Task 1 the assignment was to find a formula for the numerical value of the general element, which the students in Group 1 accomplished in terms of a recursive formula. In Task 3, however, the relations observed in the pattern are based on what I refer to as a two-stage process. The first stage can be interpreted as identification of a functional relationship,  $f$ , between position and numerical value of the lowest row in the shapes, which can be symbolised by  $f(i) = 2i - 1$ . The second stage can be interpreted as identification of a functional relationship,  $g$ , between position and numerical value of the complete shape, where the complete shape is defined as the composition of the rows. This

can be symbolised by  $g(n) = \sum_{i=1}^n f(i) = 1 + 3 + 5 + \dots + 2n - 1$ . The func-

---

<sup>102</sup> Group 1 has not engaged with Task 2 because they spent the whole time on Task 1. Group 2, however, has completed both Task 1 and Task 2.

tion  $g$  is defined as the  $n$ -th partial sum of an arithmetic series with difference 2. Hence,  $g$  can be written as  $g(n) = \frac{(1 + 2n - 1) \cdot n}{2} = n^2$ , which proves the intended conjecture about equality of the sum of the first  $n$  odd numbers and the  $n$ -th square number,  $1 + 3 + 5 + \dots + 2n - 1 = n^2$ .

As evidenced by the excerpts from the transcript above, the students of Group 1 understand that it is about adding odd numbers and getting square numbers as an answer. They exemplify by adding the first four odd numbers and getting four squared, and by adding the first five odd numbers and getting five squared. But they do not know how to represent the observed connection mathematically (Ida in turn 196). As presented in Section 7.2.2, the students have been introduced to the expression  $1 + 3 + 5 + \dots + \square = n^2$  by teacher Erik, and given the task of replacing the empty place (illustrated by a box in the above equality) with a symbolic expression for the  $n$ -th odd number. The analysis has shown that they disregard the presented equality, possibly due to their limited knowledge of syntax of formulae.

Recall that the students' conjecture for a mathematical statement in Task 3d is a function that identifies a relationship between position and numerical value of the general element of the pattern. An important issue is why this function is not an adequate solution to the problem. The nature of the knowledge aimed at in Task 3d rests in the definition of the concept of mathematical statement. This definition, however, is not known to the students, nor is the concept clarified in the course of the lesson. This is a weakness in the milieu for formulation, as explained in Section 7.2.1.

In the next section I give a brief summary of the findings presented in Sections 7.1 and 7.2, before I discuss the findings in Section 7.4.

### 7.3 Summary

Sections 7.1 and 7.2 have provided insights into the complexity of turning a situation of action into a situation of formulation of algebraic generality in shape patterns, as experienced by the students and teachers whom I have observed. Two properties of this complexity have been identified. The first property is related to the phenomenon of confusing recursive and explicit approaches to generality. This phenomenon is manifested in five different circumstances: in the students' over-generalisation of a recursive approach to an explicit approach to generality; in the production of a Jourdain effect; in the students' acceptance of an incomprehensible difference; in the students' and teacher's unawareness of each other's different foci with respect to approaches to generali-



ty (recursive versus explicit); and, in the complexity of transforming recursive properties into an explicit algebraic expression.

The second property of the complex nature of turning a situation of action into a situation of formulation of generality in shape patterns is related to the phenomenon of expectations regarding the syntax of the target mathematical object. This phenomenon is manifested in three circumstances: in identification of a need for knowledge of arithmetic series; in the students' disregard of a presented formula associated with their limited knowledge of syntax of formulae; and, in the complicated symbolisation of relations between natural numbers, odd numbers, and square numbers.

The diagram in Figure 7.11 (on the next page) presents the analytic category developed in this chapter with its subcategories and events. In the next section I discuss the findings presented in this chapter.

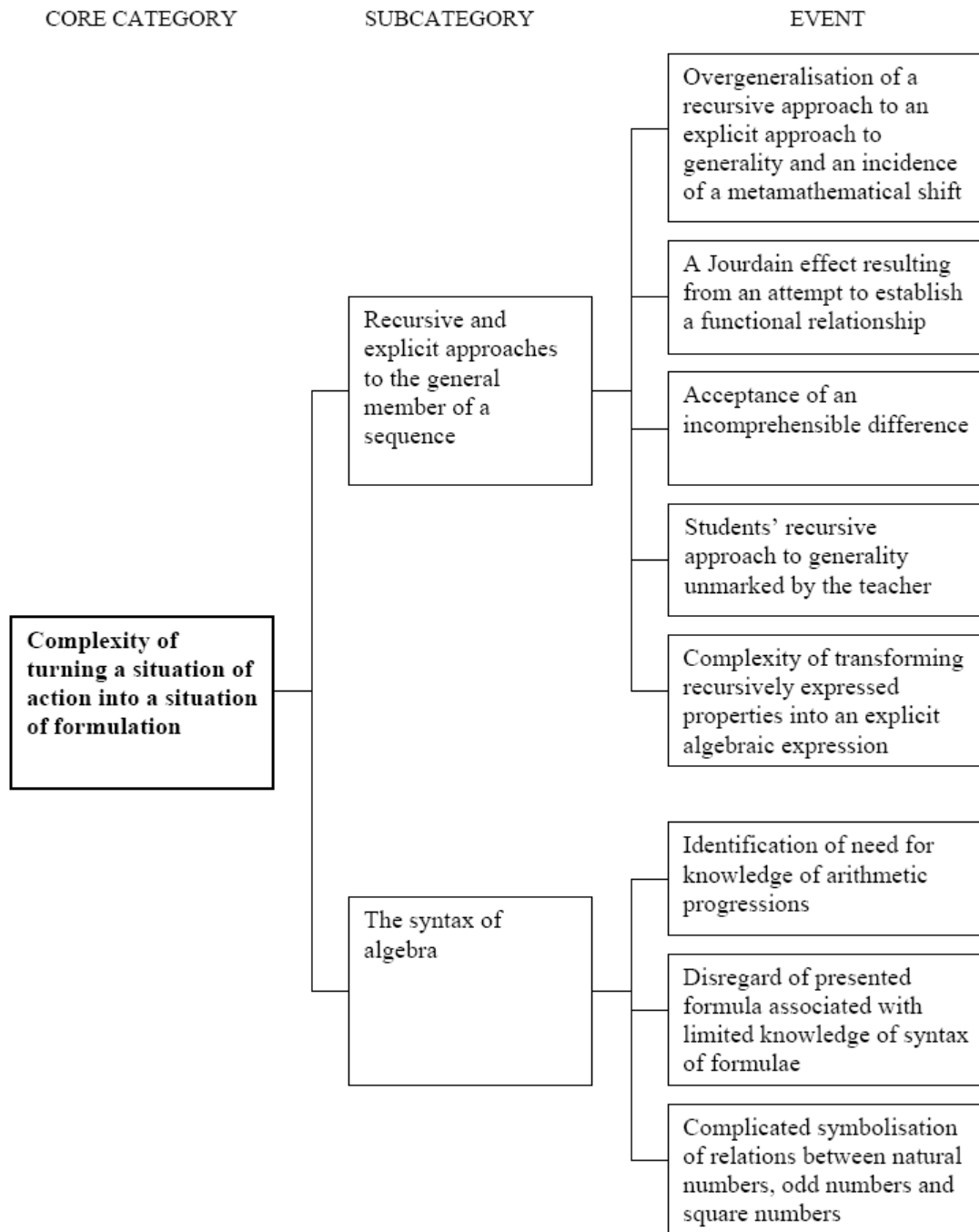

Figure 7.11. Second analytic category with subcategories and events

## 7.4 Discussion of the second analytic category

The analytic category developed in this chapter, *Complexity of turning a situation of action into a situation of formulation*, provides insights into factors that constrain students' formulation of algebraic generality in shape patterns. The discussion of these factors is presented in two parts: recursive versus explicit approaches to generality; and, algebraic symbolisation of generality in shape patterns.

### 7.4.1 Recursive versus explicit approaches to algebraic generality in shape patterns

When given the first few members of a sequence of numbers, most students are likely to apply a recursive strategy to find the next members of the sequence (English & Warren, 1998; Lannin et al., 2006; Orton & Orton, 1999; Orton et al., 1999; Stacey & MacGregor, 2001). Radford (2002b) claims that in identifying a relationship between consecutive members of a sequence, perception and natural language play a central role in the sense that the relationship can be seen and spoken about. An explicit (direct) relationship, on the other hand, requires that a point of reference is chosen and a symbolic expression in terms of a functional relationship between the point of reference (position) and the member itself is established. Here perception is much less helpful (Radford, 2002b). This may explain why many students, when they engage in generalising patterns, often focus on recursive rather than explicit relationships, as reported above.

Some researchers (e.g., Amit & Neria, 2008; Steele, 2008), however, do not consider a recursive solution to be an adequate generalisation, because it does not easily permit the calculation of values for large positions in the sequence. David W. Carraher, Mara V. Martinez, and Analúcia D. Schliemann (2008), on the other hand, point out that a recursive approach is important because “the recursive expression tends to be consistent with many young students’ conceptualizations of linear functions (p. 7). Further, Lannin et al. (2006) recommend that students should be familiar with both recursive and explicit strategies and with connections between them (see Section 3.4). This stance is supported by Dörfler (2008) who observes that the two different approaches to generality in shape patterns shed different light on the underlying relationship: A recursive approach analyses the sequence of numbers arising from the shape pattern as the position in the sequence increases; an explicit approach analyses a single generic case. The epistemological and didactical analyses in Chapter 5 have presented the mathematics potential of tasks on algebraic generalisation of shape patterns, and its potential for stimulating students’ algebraic thinking.

Results from the analysis of classroom data presented in this chapter have shown how students’ lacking awareness of the distinction between explicit and recursive approaches to generality, students’ weak fluency in symbolising relationships between variables, and the students’ and teacher’s unawareness of each other’s different foci (recursive versus explicit) have constrained the process of representing algebraic generality. It is relevant to notice that the observed students most likely had no experience in representing recursive relationships symbolically at the time the data were collected. This assumption is based on knowledge of

the mathematics curricula which were in force throughout these students' previous education: The Curriculum Guidelines for Compulsory Education in Norway, M87 (Ministry of Education and Church Affairs, 1987); The Norwegian Curriculum for Primary and Lower Secondary Education, L97 (Ministry of Education, Research and Church Affairs, 1996); and, The Norwegian Curriculum for Upper Secondary Education, R94 (Ministry of Education, Research, and Church Affairs, 1993). None of these curricula defines any learning goals or competence aims related to recursive formulae. Nor does the curriculum which replaced them do so, The National Curriculum for Knowledge Promotion in Primary and Secondary Education and Training (Directorate for Education and Training, 2006).

In the next section I argue how consideration of shape patterns contributes to generalisation in terms of algebraic notation.

#### **7.4.2 Algebraic symbolisation of generality in shape patterns**

In situations of action the observed students have engaged with the shape patterns: They have constructed subsequent elements of the respective pattern, in terms of drawings (geometric configurations) or as concrete objects (e.g., built with centicubes). Further, they have found numerical values (by counting components) of the elements, which have been used to produce tables or sequences of numbers. Additionally, they have made observations of the relationship inherent in the pattern (e.g., how the number of components grows, or how the position of an element is related to its numerical value). The students' reflections on their manipulations of the concrete or iconic models (shape patterns) are similar to the work of mathematicians, as described by Aleksandr D. Aleksandrov (1963/1999):

It is true that mathematicians also make constant use, to assist them in the discovery of their theorems and methods, of models and physical analogues, and they have recourse to various completely concrete examples. These examples serve as the actual source of the theory and as a means of discovering its theorems, but no theorem definitely belongs to mathematics until it has been rigorously proved by a logical argument. (pp. 2-3)

Aleksandrov emphasises in the last part of the quotation the need for justification of a proposed conjecture, a process I interpret to be dependent on representation of the conjectured relationships in formal mathematical notation.

The outcome of situations of action is the milieu for situations of formulation, where students formalise in mathematical notation the observations and conjectures made. Drawing on Kieran's (1989) definition of algebraic generalisation and Davydov's (1972/1990) theory of generalisation, I consider formalisation in terms of mathematical notation an important feature in the appropriation of algebraic generality. Carraher

and Schliemann (2002) claim that when students comprehensively represent relationships in mathematical notation they transform their knowledge, extending its range and significance. “Their formal representations can serve as objects of reflection and inquiry, thereby playing a role in the future evolution of their mathematical understanding” (Carragher & Schliemann, 2002, p. 299).

Mathematical objects represented in formal notation are the intended outcome of situations of formulation. In the context of algebraic generalisation of shape patterns, these objects are formulae or mathematical statements as explained in Section 6.5.2. The outcome of the situation of formulation is the milieu for the situation of validation. Justification of the proposed conjecture (a formula for the numerical value of the general element of the shape pattern, or a mathematical statement about equivalence of two expressions) depends on the conjecture being represented in formal (algebraic) notation. Its representation in algebraic notation makes it possible to manipulate the generality which represents the general element of the shape pattern. When the generality is a functional relationship (between position and member of the sequence mapped from the shape pattern), justification is in the form of a generic (decomposed) element showing references between the element and symbols in the algebraic formula. When the generality is a mathematical statement about equivalence of two expressions, justification is in the form of proving the proposed equality algebraically (by symbol manipulation).

Kieran (1996) categorises algebraic activity into three types: generational (establishing the expressions and equations that are the objects of algebra); transformational (manipulating symbols); and, global/meta-level activity. The third category of Kieran (1996) refers to activities where algebra is used as a tool but where the activities are not exclusive to algebra (e.g., problem solving, modelling, noticing structure, studying change, generalising, analysing relationships, and proving). According to Kieran (2004), the global/meta-level activities are inseparably linked to the other activities of algebra, especially the generational activities. This stance points at the importance of fluency in the syntax of algebra. Kieran claims that the algebra teacher has a crucial role to play in accentuating algebraic representations and in making students’ manipulations of them “a venue for epistemic growth” (p. 31). This statement resonates with the claims about the teacher’s role in students’ algebra learning referred to in Section 3.6 (with reference to Balacheff, 2001; Lins et al., 2001; Seeger, 1989; and Ursini, 2001).

Results from my analysis of classroom data showed that students of Group 1 did not succeed in representing the  $n$ -th odd number in algebraic notation. This circumstance I interpret to limit their ability to use the teacher’s proposed equality in their reasoning about the invariant struc-

ture of the shape pattern in Task 3d. A phenomenon that made the task even more complex is the students' and teacher's different foci (recursive versus explicit approaches), as described in Section 7.1.5. Ida expressed the  $n$ -th odd number recursively in natural language; "it has to be something with plus two because it increases by two each time" (turn 167, Task 3d). I conjecture that it perhaps would be easier for the students to reason about the  $n$ -th odd number with respect to the given task if they managed to represent Ida's observation in algebraic notation:  $u_n = u_{n-1} + 2$ , with  $u_1 = 1$  (for  $n \in \bullet \setminus \{1\}$ ).

Based on the analytic findings and discussion presented in this chapter, it is possible to reflect on relevant elements in an *a priori* analysis of a teaching situation aiming at algebraic generality in shape patterns. I consider these questions as important elements: "What is the nature of the mathematical object aimed at (functional relationship or theorem)?", "What is the nature of the intended mathematical relationship (recursive or explicit)?", "What do the intended mathematical objects require of the milieu?", "What types of representations and syntax of formulae are expected to be familiar to the students (iconic configurations, natural language, algebraic notation, graphic)?", "What should happen if they are not?", "How can the knowledge developed by students in situations of action, formulation and validation be institutionalised?"

In Chapter 9 I will present a synthesis of the analytic categories developed in my study, which includes a discussion of the complexity of developing the scientific concept of "mathematical statement" (Section 9.2). In the next chapter I present the third analytic category that emerged from the analysis. It is referred to as *Complexity of operating in the situation of validation*.

## 8 Complexity of operating in the situation of validation

In this chapter I present the third analytic category that emerged from the exploration of the student teachers' collaborative work on algebraic generalisation of shape patterns. I have analysed classroom data only from Group 1. The reason for this is that Group 1 was the only one where a teacher intervened in the situation of validation.<sup>103</sup> The data are analysed with the purpose of finding answers to the research question presented in Chapter 4, "What factors constrain students' appropriation of algebraic generality in shape patterns?" The analysis draws on the epistemological and didactical analyses of the mathematics potential in the tasks presented in Chapter 5. The analytic category is called *Complexity of operating in the situation of validation* and consists of two subcategories which are phenomena that define the category.

First, I present a feature of the milieu for the situation of validation which is about the pertinence of concepts, where spontaneous concepts do not "carry" the mathematical rigor required (Section 8.1). Then, I present a feature of the milieu for the situation of validation which is about the distinction between empirical reasoning and mathematically valid reasoning (Section 8.2). Next, a summary of the findings is presented (Section 8.3). The chapter closes with a discussion of how the identified features constitute shortcomings in the milieu for validation of algebraic generality in shape patterns (Section 8.4).

### 8.1 Pertinence of concepts (spontaneous versus scientific concepts)

In this section I present the first subcategory of *Complexity of operating in the situation of validation*. The subcategory presents features of the milieu for validation, and provides insights into how the students' justification of algebraic generality in shape patterns is constrained. It is manifested in the act of explaining what is meant by "structure" and "structural relationship".

---

<sup>103</sup> Students of Group 2 also engaged with the justification part of Task 3, but their (empirical) reasoning was not challenged at any time. Hence, they were left to believe that they had accomplished a valid proof, even if their proof did not have the required rigor, as explained in Section 6.1.2.

### 8.1.1 Explaining what is meant by “structure” and “structural relationship”

During their engagement with the first part of Task 3 (the staircase tower pattern in which the objective is to produce a mathematical statement about equivalence of two expressions), the students of Group 1 have, with some help from teacher Erik, formulated that the sum of the first  $n$  odd numbers is equal to the  $n$ -th square number. The mathematical statement is represented in algebraic symbols by the equality  $1 + 3 + 5 + \dots + 2n - 1 = n^2$  and has been verified for  $n \in \{2, 3, 4, 5\}$ . The teacher asserts that because this equality is not obvious, it is necessary to prove mathematically that it is true in all cases. He continues:

392 Teacher E: For the time being we have a hypothesis because we have tried with three and four and five and perhaps more, but we have still tried only for a finite number of cases. We just have some examples, so at present it is about raising ourselves to a more superior plane and see the structure.

[Task 3, Group 1]

I interpret this utterance by the teacher to be his way of mediating what distinguishes, in this situation, mathematical reasoning from empirical reasoning. Recall from Section 6.1.2 (Figure 6.3) that he has designed the second part of Task 3 with the intention that the students use structural arguments to prove the conjecture from the first part of Task 3. The structural reasoning intended by the teacher is based on the students' familiarity with two types of shapes: First, it is based on familiarity with rectangles, which involves that the students use that the number of components is equal to the product of the number of columns and the number of rows, thus relating the number of components to the area of a rectangle. Second, it is based on familiarity with triangular numbers, which involves that the students know that the number of components of the  $n$ -th triangular number is equal to  $\frac{n}{2}(n + 1)$ . Next, the task is based on the

recognition that an element of the staircase tower pattern can be seen as a rectangle where two triangles are removed. Arithmetically, this means that a member of the sequence mapped from the staircase tower pattern is equal to the difference between a member of the sequence mapped from the rectangle pattern and a member of the sequence mapped from twice the triangle number pattern.

The students of Group 1, however, establish a formula for the general member of the sequence mapped from the rectangle pattern by empirical reasoning based on the first four elements of the pattern of rectangles as drawn by Sophie (Figure 8.1 on the next page). Table 8.1 (on the next page) is a reproduction of the table made by Sophie. The students find



that a formula for the  $n$ -th element of the sequence of rectangles is given by  $n^2 + n \cdot (n - 1)$  (their reasoning is illustrated in Figure 6.4, Section 6.2.1). The way they justify generality by empirical reasoning is shown in the transcript below.

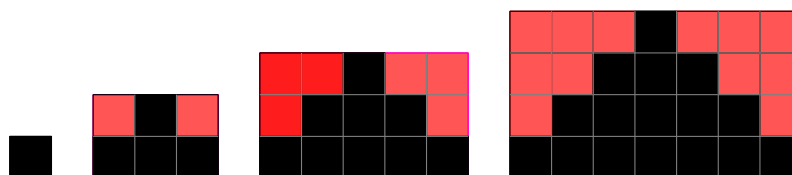

Figure 8.1. Sophie's illustration of the first four rectangles in the pattern in Task 3 (Part II)

**Table 8.1. The number of black and red squares in the rectangles as written by Sophie**

N	1	2	3	4	5
number	1	(4 + 2)	(9 + 6)	(16 + 12)	
468 Ida:		Four plus two?			
469 Sophie:		Yes, if you look here at the second [element] (Ida: uh huh) then we have got two three four black (Ida: yes) and two red [Sophie counts black and red squares in the second element in her pattern as drawn in Figure 8.1 above] (Ida: uh huh). Hence I write four plus two.			
470 Ida:		Ok.			
471 Sophie:		Shape three, here you have got one two three four five six seven eight nine black			
472 Ida:		plus six			
473 Sophie:		one two three four five six. [Pause 9 s] And here you have got one two three four five six yes seven [Pause 1-3 s] no nine ten eleven twelve thirteen fourteen fifteen sixteen plus twelve (Ida: uh huh). Sixteen black plus twelve red. [Pause 20 s]			
474 Sophie:		We can indeed try to make or calculate with seven and afterwards draw and look if it is correct. (Ida: uh huh).			
M					
478 Ida:		Seven times six is 42. 49 plus 42. [Sophie draws a tower with 1+3+5+7+9+11+13 black squares and then picks up the red pen] No, just continue to draw. [Ida counts how many rows the tower spans]			
479 Sophie:		What?			
480 Ida:		I will just check how many there are. [She counts the number of squares at the bottom row] Thirteen.			
481 Alice:		It is seven times thirteen.			
482 Ida:		Yes.			

- 483 Alice: Haven't calculated this [product]. [Sophie colours with red the rest of the rectangle. Ida verifies that  $49 + 42$  is equal to  $7 \cdot 13$  by calculation]
- 484 Ida: It becomes true. This is correct. Good, Sophie! [excited voice]
- 485 Sophie: Ok then [smiles] [Pause 1-3 s]
- 486 Ida: Was it correct for more values? Have you done several? [to Alice]
- 487 Alice: No, I have only checked for [element number] four. There it is correct.
- 488 Ida: Yes, and it's correct for seven [Pause 1-3 s]  
[Draws a frame around the formula like this  
 $n^2 + n \cdot (n - 1)$ ]

[Task 3, Group 1]

Turns 469, 471, and 473 suggest that Sophie is concerned with the number of black and red squares; she is not focusing on the structure of the elements in terms of shape. This is signified by her counting the black and red components from the beginning in the second, third, and fourth elements of the pattern. She verifies that the addends  $n^2$  and  $n(n - 1)$  in the formula they have established correspond to the numbers of black and red squares in the rectangles, respectively. Justification of their conjectured formula by Sophie in turns 469 – 473 is seen to be done by *naïve empiricism* (Balacheff, 1988) for  $n \in \{2, 3, 4\}$ . In turn 474 Sophie suggests that they test the conjecture for  $n = 7$ , which I interpret as a call for a *crucial experiment* (Balacheff, 1988) to be carried out. Ida's verification of the fact that the sum of the addends in the formula when  $n = 7$  is equal to the product of the width and length of the seventh rectangle (as commented in turn 483) leads her to assume that the conjectured formula is correct. The conclusive nature of Ida's assumption is indicated by her excited voice in turn 484 and her drawing of a frame around the formula, as commented in turn 488.

As Balacheff (1988) observes, justification of a mathematical statement by naïve empiricism or by a crucial experiment is not a valid mathematical proof. The intention with including the sequence of staircase towers in a sequence of rectangles was to use familiar shapes, as explained above. This is what the teacher referred to when he talked about seeing the *structure* (turn 392 above). When the teacher realises how the

students of Group 1 have justified their conjectured formula, he claims that a number of examples, regardless how many, can never prove that a property is true in all cases.<sup>104</sup> The following exchange takes place:

- 549 Teacher E: In order to be quite sure, we have to raise ourselves in the sense of seeing a superior structure in our system. What we now *believe* is that the number of dark squares is  $n$  squared. But we don't know it because we have only verified it in some particular cases. [Sophie looks at the teacher with slightly lifted eyebrows; Alice leans the head in her left arm]
- 550 Ida: So this isn't quite correct? [She laughs and points at the expression  $n^2 + n \cdot (n - 1)$ ]
- 551 Teacher E: Not correct in the sense that you can kind of defend it in a trial yet.
- 552 Ida: It is not the one that we were supposed to obtain.
- 553 Sophie: But it is correct [Pause 1-3 s] or what?
- 554 Teacher E: Correct, in what way is it correct?
- 555 Sophie: It is correct if we put the numbers in [the formula]. Put them in.
- 556 Teacher E: Yes, but then you have [verified] it only for some examples.
- 557 Sophie: Yes, but this applies for all the formulae that we invent, doesn't it?
- 558 Teacher E: Well, so this is really the first time we have challenged you to go beyond [Pause 1-3 s] No we have in fact done that before. But there is actually a leap from testing some examples and getting a conjecture, to really proving that it is true. And in order to prove that it really is true, we have to see a structure that is *independent* of choosing three or five or seven, which is more about the whole [Ida nods] and the structural relationship in a way. And that is not so obvious to see in these shapes [he points at the sequence of staircase towers] so the reason why I have added the white squares here was to help you. It may be easier to identify the structure of this pattern [sequence of rectangles] than of that pattern [sequence of staircase towers].
- 559 Sophie: I can't really get the picture here now. I don't quite understand. [Pause 1-3 s] What, what are we supposed to get at then?

[Task 3, Group 1]

---

<sup>104</sup> The teacher's claim may be experienced by himself as a truth, whereas the students may sense the truth value only because the teacher says it is so. It is possible that the students have no experience of when the type of naïve empiricism they have employed in this problem breaks down.

The first sentence of turn 549, which basically repeats the teacher's utterance in turn 392, is the teacher's guidance for action. It is supposed to mediate what needs to be done in order for the conjectured formula to become a theorem (i.e., to prove it). However, Ida's and Sophie's questions in turns 550, 552, 553, 555, and 557 indicate that they have not understood what is asked for. An attempt to explain what he means by "raising ourselves to a more superior plane and see the structure" (turn 392) and "seeing a superior structure in our system" (turn 549) is made when he says that "in order to prove that it really is true, we have to see a structure that is *independent* of choosing three or five or seven, which is more about the whole and the structural relationship in a way (turn 558). Expressions used by the teacher (turns 392, 549, and 558) to mediate and explain what it takes to accomplish a mathematical proof are: "raise oneself"; "structure"; "structural relationship"; "the whole"; "superior structure"; "superior plane"; and, "system". Later, the teacher uses the formulation "level above the level of examples" to mediate that it takes more than examples to justify mathematically that a formula is correct:

577 Teacher E:        So that  $n$  squared must be the result of a process which must be on a level above the level of examples.

[Task 3, Group 1]

These concepts have particular connotations when used in this situation; they carry with them the meaning of generality and regularity (invariance). However, the concepts used by the teacher also have everyday meanings, without the theoretical meaning as referred to above. If the students attach the everyday meanings of the concepts, it is less likely that they develop awareness of the nature of a mathematical proof (and of what distinguishes it from naïve empiricism).

Sophie's confusion as expressed in turn 559 I interpret to be about the role of the two different sequences of which the teacher talks (staircase tower pattern, and rectangle pattern). This interpretation is supported by the next utterances from the transcript:

560 Teacher E:        You can prove the formula for that pattern [he points at the sequence of staircase towers] by finding the formula for this pattern [he points at the sequence of rectangles]. We are

- supposed to find a deeper connection for the black shapes by utilising the structure of this pattern [rectangles].<sup>105</sup>
- 561 Sophie: Yes, but how is it? [Pause 1-3 s] What do you talk about now? Are we supposed to find a deeper connection for that one [staircase towers] or this one [rectangles]? It is indeed this one [rectangles] we have worked on.
- 562 Teacher E: In fact, *that* one. [He points at the sequence of staircase towers]
- 563 Sophie: That one? Well, but then we have to look at another formula which we have established.
- 564 Alice: Yes, we have  $n$  squared as a formula for that one.
- 565 Teacher E: Well, that is a conjecture.
- 566 Alice: Ok.

[Task 3, Group 1]

The teacher presents in turn 560 the role played by the sequence of rectangles in proving the formula from the first part of the task. Sophie reveals in turns 561 and 563 that she is unaware of the role of the rectangles in proving the original conjecture about a relationship between odd numbers and square numbers. As explained in Section 6.1.2, this suggests that the students treat the second part of Task 3 as a new generalisation task aiming at a formula for the general member of the sequence mapped from the rectangle pattern (instead of a proof of the conjecture about equivalence of the  $n$ -th square number and the sum of the first  $n$  odd numbers).

The students of Group 1 seem unaware that *the way* they derive the formula for the general member of the sequence mapped from the rectangle pattern is of crucial importance. This will be explained in the next section, where I present the second subcategory of *Complexity of operating in the situation of validation*.

## 8.2 Distinction between empirical reasoning and formal, rigorous mathematical reasoning

In this section I present the second subcategory of *Complexity of operating in the situation of validation*. The subcategory presents features of the milieu for validation, and provides insights into a tension between empirical reasoning and mathematical reasoning. The phenomenon de-

---

<sup>105</sup> Recall that the “black shapes” are included in the rectangle pattern (see Figure 7.8 in Section 7.1.5); they represent the elements of the staircase tower pattern from the first part of the task.

scribed by this subcategory is manifested in two circumstances: in consciousness of the importance of how a formula is derived; and, in the act of explaining the disparity between two equivalent formulae that are derived in different ways.

### 8.2.1 Unawareness of the importance of how a formula is derived

The following exchange supports the plausibility of the interpretation that the students of Group 1 do not have in mind that the formula for the rectangle pattern has a role in proving the formula for the staircase tower pattern:

- 571 Alice: That pattern [the staircase towers] is the same as the black squares in this pattern [rectangles] and that is the one with which we are going to start now, so there we haven't made up our minds or done anything yet.
- 572 Teacher E: Well, I thought you might have done that because you have written this down. [He makes a circle around the formula for the rectangles in Ida's notebook,  $n^2 + n \cdot (n - 1)$ ]
- 573 Sophie: This is indeed the formula.
- 574 Alice: The reason why we used  $n$  squared here is that we used  $n$  squared in the first part of the task. Hence, it was just replicated down here.

[Task 3, Group 1]

As explained in Section 6.1.2, Task 3 (Part II) is designed to evoke a proof of the conjecture about equivalence of two expressions. The point is to establish the validity of two formulae: First, a formula for the general member of the sequence mapped from the rectangle pattern by utilising structural relationships. Second, a formula for the general member of the sequence mapped from the white squares pattern (triangular numbers, assumed known structure). The essence is that the general member of the sequence mapped from the staircase tower pattern is equal to the difference between the two formulae. Alice shows in turn 574 how they have figured out the total number of squares in the  $n$ -th rectangle: Instead of having established a formula for the general member of the sequence mapped from the rectangle pattern by utilising structure (width times length), they have written the total number of squares in the  $n$ -th rectangle as the sum of the number of black squares,  $n^2$ , and the number of white squares,  $n \cdot (n - 1)$ , in the  $n$ -th rectangle. The number of black squares in the  $n$ -th rectangle they write as  $n^2$ , a consequence of replicating the conjecture from the first part of the task. Because this is what they are supposed to prove, the proof process as intended by the teacher collapses.

There is a disparity between a formula being a conjecture based on empirical reasoning (guess-and-check) and a formula derived from structural reasoning (utilising structural relationships). This disparity does not

necessarily occur at the symbolisation level; a formula derived from empirical reasoning can be (syntactically) identical with a formula derived from structural relationships. This fact contributes to the complexity of understanding that it is not the formula as such that may be inadequate – the point is *how it is derived*. The students' formula,  $n^2 + n \cdot (n - 1)$ , does indeed represent the generality in the sequence of rectangles. But it is derived by a chain of empirical reasoning rooted in the numbers, not by reasoning on the basis of structural relationships evident in the shapes. When the teacher, as a response to their having used the conjecture that they were supposed to prove, claims that they have just repeated the hypothesis, Alice says:

576 Alice:                    So actually, we should have found a completely different formula for the rectangles? If we were to enter a new plane, we should not have used what we had first?

[Task 3, Group 1]

Alice's utterance illustrates the intricacy of the connection between generalisation and proof. To come up with a different formula, as Alice indicates, is not the point because (as commented above) different formulae for the same pattern will be equivalent. It is possible to derive identical syntactical expressions by empirical and structural reasoning. However, empirical reasoning does not, within accepted convention, justify the formula arrived at, whereas structural reasoning (using the properties of one of the elements in the shape pattern, a generic example) justifies the formula (Balacheff, 1988). Sophie does not seem to understand what is wrong with their original formula for the rectangles. When the teacher tries to explain that structure has to do with expressing the width and length of the  $n$ -th rectangle in terms of  $n$ , Sophie says:

580 Sophie:                    Yes, but we have indeed written in parenthesis nine plus six. Nine black ones plus six white ones.

581 Teacher E:                Yes, indeed. I do not doubt that, you see.

582 Sophie:                    Then it will be [Pause 1-3 s]

583 Alice:                     It is the wording of the formula which is, is not what [Pause 1-3 s] is not desirable [Pause 1-3 s] because it is a bit too [Pause 1-3 s] shallow or how shall I put it. [Laughs a bit]

[Task 3, Group 1]

Alice's hesitation and tentative formulation in turn 583 about wording and properties of their original formula indicate the complexity of mediating what is involved in establishing a formula by structural reasoning. With guidance from teacher Erik, Alice succeeds in expressing the width and length of the  $n$ -th rectangle. Afterwards the group collaborates and develops a formula by structural reasoning. Sophie, however, is not familiar with the reason why they need to establish the formula once again.

After she has taken part in developing the formula,  $n \cdot (2n - 1)$ , by utilising structure, she asks:

708 Sophie:           What was wrong with the first one [the formula] that we made? That it wasn't [Pause 1-3 s] correct?

[Task 3, Group 1]

It is not surprising that this question comes up, because their original formula had turned out to give the correct values in the cases checked. Sophie is probably convinced by empirical reasons that their formula is correct and does not understand why they should consider it inadequate.

In the next section I present the complexity of explaining the difference between a formula based on naïve empiricism and a formula based on structural reasoning. It is the second manifestation of *Distinction between empirical reasoning and formal, rigorous mathematical reasoning*.

### 8.2.2 Explaining the disparity between two equivalent formulae

When Sophie asks what was wrong with the first formula they had developed, the subsequent dialogue reveals the intricacy of explaining and understanding the disparity between the two equivalent formulae for the rectangles.

709 Alice:           Well, it is written here later, it is written that we shall discuss if the conjecture from earlier in the task can be considered proved now. If we get the same [formula] now, we can say that it is proved because we are on a higher plane.

710 Sophie:         Yes, but this one, we did indeed make one for the dark ones first?

711 Ida:             Uh huh

712 Alice:         Yes, that one [interrupted by Sophie]

713 Sophie:         It [the first formula] doesn't work?

[Task 3, Group 1]

Sophie in turns 710 and 713 refers to the conjectured formula for the general member of the sequence mapped from the staircase tower pattern from the first part of the task (the statement of a function,  $a_n = n^2$ ). I interpret her questions to demonstrate that she does not have a clear conception of the intention with the second part of the task (its role in proving the conjecture from the first part of the task, as explained in the previous section).



Then follows an exchange between the students that reveals confusion about three formulae: first, the formula for the rectangles<sup>106</sup> (derived by naïve empiricism); second, the formula for the rectangles developed with the teacher’s guidance (derived by structural reasoning); and third, the formula for the staircase towers (derived by naïve empiricism). The pronouns “it”, “this”, and “that” are used to denote the formulae at stake. In some of the utterances these words create uncertainty about which formula is referred to (e.g., turns 719, 721, 729, 732, 734, 735 in the transcript).

- 714 Alice:  $n$  squared doesn’t work?  
 715 Ida: Right.  
 716 Alice: Because it is not [a formula] for the black [ones]?  
 717 Sophie: Indeed it is.  
 718 Alice: No [Pause 1-3 s] it was for the whole figure?<sup>107</sup>  
 719 Sophie: No, it was *this* one.  
 720 Alice: The first one we made for the whole figure [the rectangle pattern] is the one you have written in red there. [Refers to the expression  $n^2 + n \cdot (n - 1)$ ]  
 721 Ida: But this one was wrong.  
 722 Sophie: So, this one is wrong? [Points at the expression  $n^2 + n \cdot (n - 1)$ ]  
 723 Ida: Or well, we couldn’t use it.  
 724 Teacher E: Not *wrong*  
 725 Ida: not wrong but we couldn’t [interrupted by Alice]  
 726 Alice: It was not on the *right plane*  
 727 Ida: yes [Alice and Ida laugh]  
 728 Teacher E: But you took for granted that the number of black ones was  $n$  squared (Alice: uh huh) [Pause 1-3 s] whereas the point was that [interrupted by Ida]  
 729 Ida: Then we made a new one for the black [components] because *that* [she points in Sophie’s notes] is the black [interrupted by Sophie]  
 730 Sophie: no  
 731 Ida: not the *whole* I mean. This was the one we *had* for the whole.  
 732 Sophie: No, we had this one for the black

---

<sup>106</sup> “Formula for the rectangles” is shorthand for the stringent expression “formula for the general member of the sequence mapped from the rectangle pattern”. The same applies to subsequent references to formulae (for the same or for other patterns) in this text.

<sup>107</sup> The “whole figure” refers to the pattern of rectangles as presented in Task 3 (Part II). The “black ones” refer to the pattern of staircase towers included in the rectangles.

- 733 Alice: no  
 734 Sophie: no this one was for the *whole*, right?  
 735 Ida: But we couldn't use it though.  
 736 Teacher E: We don't have anything else [interrupted by Sophie]  
 737 Sophie: And that one was the whole previously and this one is the whole now. [Refers to the formulae  $n^2 + n \cdot (n-1)$  and  $n \cdot (2n-1)$ , respectively]  
 738 Ida and Alice: uh huh  
 739 Teacher E: The expressions are indeed the same, but it is on the mental plane they are different [Pause 1-3 s]  
 740 Ida yes [very low voice]  
 [Task 3, Group 1]

When Ida claims that the first formula they developed for the rectangles was wrong (turn 723), teacher Erik corrects her by saying “not wrong” (turn 724). Alice then adjusts her statement by saying that it was “not on the *right plane*” (turn 726), and thereby repeats what she said in turn 709 about being on a “higher plane”. This wording by Alice and her emphasis on the words “right plane”, I interpret to be the result of taking over speech from the teacher when he tried to explain what it means to prove something mathematically. He said that “it is about raising ourselves to a more superior plane and see the structure” (turn 392, Section 8.1.1). Ida and Alice’s laughter in turn 727 may signify that Alice’s observation (turn 726) is just a recitation of the teacher’s utterance (turn 392) and that it is not really understood by them.

The above shows that there is confusion caused by the fact that there are two equivalent formulae: the formula for the rectangles developed by the students (based on naïve empiricism), and the formula developed under guidance from the teacher (based on structural relationships). The teacher acknowledges that the formulae are equivalent and expresses that it is on the mental plane they are different (turn 739). He further attempts to explain what distinguishes a hypothesis based on empirical reasoning from a mathematically valid argument:

- 741 Teacher E: There is a disparity between, on the one hand, having a hypothesis that it will be  $n$  squared, and, on the other hand, being able to see it at a level where we are independent of having checked for four and seven and ten and so on. We kind of [Pause 1-3 s] lift ourselves from the particular examples up to a more like [Pause 1-3 s] a plane where we see [Pause 1-3 s] structure. That may be an appropriate word for it. [Low voice in whole turn]

[Task 3, Group 1]

Teacher Erik here tries to convey what I interpret to be the utility of a generic example, where he talks about generality and structure (regularity). His low voice and tentative formulation in the last sentence, howev-

er, may indicate that he finds it complex to convey the nature of mathematical rigor. The teacher then leaves the students to finalise the task.

The students then compute the difference between the expressions derived by structural reasoning,  $n \cdot (2n - 1) - n \cdot (n - 1)$ , and find that it is equal to  $n^2$ , as conjectured. The transcript below shows their discussion about whether they then can consider the conjecture as proved:

- 787 Alice: Now it is proved because we have indeed gone the whole way once more.
- 788 Sophie: Yes.
- 789 Ida: But the way we started, why wasn't it proved then?
- 790 Alice: Because we hadn't taken the complete, heavy way as we have done now.
- 791 Ida: I don't quite understand what heavy way we have gone.
- 792 Alice: Because now we didn't look only at [Pause 1-3 s] we did not look, we hadn't drawn them all and [Pause 1-3 s] well, here it may be a connection, and there it may be a connection. We rather looked at [Pause 1-3 s] we considered a single one and found out that it applied for all.
- 793 Ida: Ok.
- 794 Sophie: Well, but [holds the task sheet up in the air] [Pause 1-3 s]
- 795 Alice: The next subtask is just for those who want. [Proof by induction of the same formula]
- 796 Sophie: I don't think we are qualified to do the rest of the task. [All three laugh loudly]

[Task 3, Group 1]

Alice's answer (turn 790) to Ida's question why the formula was not proved by their first approach does not give any information about the character of the formula developed under the teacher's guidance. The notion "to be developed by the heavy way" gives no information about what distinguishes it from their original formula. Alice just repeats her opinion as put forward in 787, on the basis of which Ida's responses (turns 789 and 791) are made. This indicates the intricacy of verbalising what it means to utilise structural relationships. Alice, however, in her follow-up response (turn 792), does to some extent describe the quality of the last formula by the way she expresses that they, rather than having looked at several examples, considered a single example and found out that it applied to all. This is an important property of a generic example (Balacheff, 1988; Mason & Pimm, 1984) which is possibly understood by Alice, though not so precisely formulated.

Even if Ida and Sophie pose no further questions related to the distinction between the two formulae, it is plausible that they do not completely understand it. This claim is supported by Sophie's statement (turn 796) about their lacking qualification to accomplish the optional subsequent subtask (which involves a proof by induction to justify the intend-

ed mathematical statement). Their subsequent laughter I interpret as reinforcing the validity of the assumption about lacking comprehension.

In the next section I give a brief summary of the findings presented in Sections 8.1 and 8.2, before I discuss the findings in Section 8.4.

### 8.3 Summary

Sections 8.1 and 8.2 have provided insights into the nature of operating in the situation of validation of algebraic generality in shape patterns, as experienced by the students and teachers whom I have observed. Two properties of this nature have been identified. The first property is related to pertinence of concepts (spontaneous versus scientific concepts) related to explanation of what it means to accomplish a mathematical proof. This phenomenon is manifested in one circumstance: in the act of mediating what is meant by the notions “structure” and “structural relationship”.

The second property of the nature of operating in the situation of validation is related to the distinction between empirical reasoning and formal, rigorous mathematical reasoning. This phenomenon is manifested in two circumstances: in consciousness of the importance of how a formula is derived; and, in the act of explaining the disparity between two equivalent formulae.

The diagram in Figure 8.2 presents the analytic category developed in this chapter with its subcategories and events.

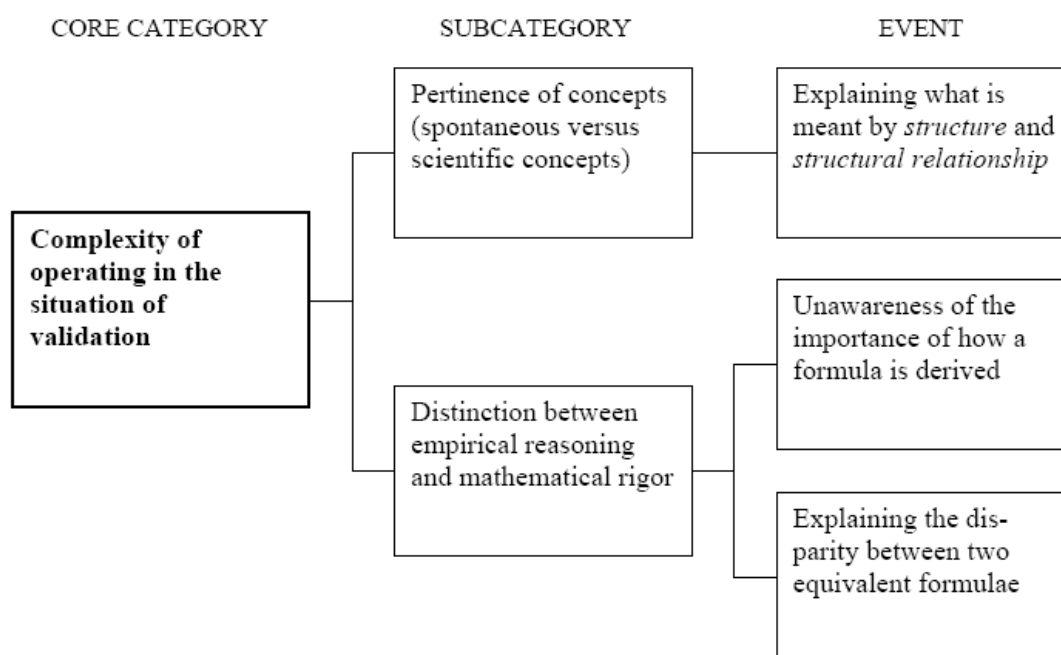

Figure 8.2. Third analytic category with subcategories and events

In the next section I discuss the findings presented in this chapter.

## 8.4 Discussion of the third analytic category

The analytic category developed in this chapter, *Complexity of operating in the situation of validation*, provides insights into factors which constrain students' justification of algebraic generality in shape patterns. The discussion of these factors is presented in two parts: an attitude of proof; and, validity of reasoning.

### 8.4.1 An attitude of proof

As outlined in Section 2.4.3, the situation of validation is about establishment of theorems. Brousseau (1997) claims that “to state a theorem is not to communicate information, it is always to confirm that what one says is true in a certain system” (p. 15). By this I understand the practice of using definitions, axioms, and previously proved results to establish the truth of statements one puts forward by utilising deductive logic. Such a practice depends on a stance which Brousseau (1997) refers to as an *attitude of proof*. He claims that such an attitude is not innate in persons, and that it therefore needs to be developed and sustained through specific didactical situations; that is, situations of validation.

Balacheff (1991) emphasises the importance of designing validation situations in such a way that students come to realise that there is a *risk attached to uncertainty*, and hence, motivate students to find a mathematically acceptable solution. Drawing on Bourdieu's<sup>108</sup> principle of *economy of logic*, Balacheff claims that students “are likely to bring into play no more logic than what is necessary for practical needs” (p. 180). Hence, “most of the time students do not act as theoreticians, but as practical persons” (Balacheff, 1991, p. 187). The students' task is to give a solution to the mathematical problem given to them by the teacher, which is acceptable in the classroom situation:

[The most important thing for] the practical person is to be efficient, not to be rigorous. It is to produce a solution, not to produce knowledge. Thus the problem solver does not feel the need to call for more logic than is necessary for practice. That means that beyond the social characteristics of the teaching situation, we must analyse the nature of the target it aims at. If students see the target as “doing”, more than “knowing”, then their debate will focus more on efficiency and reliability, than on rigor and certainty. (Balacheff, 1991, p. 188)

---

<sup>108</sup> Bourdieu, P. (1980). *Le sens pratique*. Paris, France: Éditions de Minuit.

Balacheff's claims about students' behaviour during engagement with mathematical proofs are supported by results from a study he accomplished with students in eighth and tenth grade. Based on these claims, it is relevant to concentrate on how to make the students focus on rigor and certainty. The question is how to negotiate students' acceptance of new rules, rules which involve that the goal is to establish the *truth* of some statement, not just to obtain *agreement* of the validity of the statement.

As explained in Section 6.1.2, the second part of Task 3 is designed with the intention of guiding the students step by step towards a proof of the conjecture developed in the first part of Task 3. That is, to prove the mathematical statement that the sum of the first  $n$  odd numbers is equal to the  $n$ -th square number. The analysis of the two groups' engagement with the proof was presented in Section 6.1.2. It showed how Group 1 accomplished the subtasks, one at a time, apparently without awareness of the role of the subtasks in proving the conjecture about equivalence of two expressions. The students of Group 2 were aware of the role of the different subtasks in proving the conjecture, but failed in producing a valid proof because they did not justify each step in the proof process.

The task (Task 3, Part II), designed to evoke a proof of the conjectured equivalence relation, consists of a detailed description of stepwise action. The well-structured subtasks leave little initiative to the students to decide what to do. It is a matter of the task allowing the students to be efficient instead of rigorous, because if they do the subtasks, one at a time, they are supposed to constitute a valid proof. But success in proving the original conjecture does nevertheless depend upon the students having an attitude of proof. This means that the constituents of the proof established in the subtasks (from which the target mathematical statement is supposed to be deduced) need to be justified. As accounted for in Section 6.1.2, both groups fail in this respect: Group 1 because they take as a premise what they are supposed to prove; Group 2 because they use naïve empiricism to establish a mathematical statement used to deduce the original mathematical statement.

The analytic findings presented in this chapter give insights into the complexity of getting students to grasp what distinguishes reasoning based on examples from mathematically valid reasoning. It has been presented how words with an everyday meaning fall short in communicating mathematical rigor. Even concepts like "structure" and "structural relationship" (commonly used in mathematics) do not seem to be helpful for the students in explaining what it means to produce a valid proof of a mathematical statement about generality in a shape pattern. I conjecture that the students of Group 1 perhaps would benefit from the concept of structure being elaborated and discussed in the context of the given task (what is meant by "structure"). The expressions used in the dialogue to

mediate what it takes to make a mathematical proof were these: “raise oneself”; “structure”; “structural relationship”; “the whole”; “superior structure”; “superior plane”; “system”; and, “level above the level of examples”. These expressions can be characterised as spontaneous concepts, but they are used by the teacher with a scientific meaning (i.e., they are scientific concepts; Vygotsky, 1934/1987). The many different expressions indicate that it is complicated for the teacher to explain what distinguishes empirical reasoning from mathematically valid reasoning. Similarly, it is difficult for the students to understand precisely what the teacher is after because of the everyday connotation of these expressions.

#### 8.4.2 Validity of reasoning

Several studies have showed that students struggle to establish the validity of general statements and, further, that students are likely to rely on empirical validation (Balacheff, 1988; Chazan, 1993; Healy & Hoyles, 2000; Hoyles, 1997; Lannin, 2005; Martin & Harel, 1989).

Task 3 (Part II) is designed such that there is no risk (Balacheff, 1991) involved with being practical (do the subtasks) instead of being rigorous (make sure that all steps are justified). The analysis presented in this chapter shows that the students, when solving Task 3, developed formulae without focusing on their general nature. The students in the observed episode are seen to be practical; they produce answers which they have reason to believe is acceptable in the classroom context: They have accomplished all the subtasks and thereby established a formula,  $n^2 + n \cdot (n - 1)$ , which generates correct values for several positions in the rectangle pattern (see Section 8.2.2). The adidactical situation turns into a didactical situation when the teacher intervenes and explains to the students that what they have done is not adequate. The students are convinced by empirical reasons that their formula is right; output values of the formula are in agreement with numbers arising from counting components of the first few elements of the shape pattern. That their formula is unsatisfactory is therefore surprising for them.

Following Kieran (1989), algebraic generalisation is a process which aims at representing a generality by algebraic notation. In the context of shape patterns, it means to find a mathematical object which represents the general member of a sequence mapped from geometrical configurations which constitute the pattern. As elaborated in Section 5.2.1, there are different approaches to this generality, which brings about the formula aimed at. At the level of *representing* generality, a formula is judged only by its utility to represent generality correctly. Its algebraic manifestation can vary, but syntactically different formulae (if correct) are equivalent. However, at the level of *justifying* generality (proving that a formula is correct in all cases), it is significant *how* a formula for gener-

ality is derived. That is, it is important that all steps towards the formulaic expression are justified.

The analysis presented in this chapter has given insights into the complexity of distinguishing between two types of reasoning about algebraic generality: empirical reasoning and structural reasoning. The complexity is related to explication and comprehension of what is meant by a mathematical proof. This has been identified in two factors which constrain the milieu for the situation of validation: first, in the use of everyday concepts which lack the necessary scientific precision; second, in students' lacking consciousness of the importance of how a formula is derived.

It is my conjecture that the teacher and the students perhaps would benefit from operating with the concept of a *generic example* (see Section 3.2 and Section 5.2). It has the potential to capture the meaning of the concepts "structure" and "structural relationship. According to Mason (1996), it is important for teachers (and I would add, for students) to explain what makes an example generic, because students often see an example presented by the teacher as just a particular case and do not experience it as an example of a general notion. Mason & Pimm (1984) pose the question:

How can you expose the genericity of an example to someone who sees only its specificity? Apart from stressing and ignoring, and repeating the general statement over and over, how can the necessary act of perception, of seeing the general in the particular, be fostered? (p. 287)

In the context of generalisation of shape patterns, I suggest the act of decomposition (presented in Section 5.2) by dividing the first few geometrical configurations into different partitions (to identify the invariant structure of the shape pattern) would be an answer to Mason and Pimm's question. Important in this respect is teachers' and students' articulation of what makes an example generic. In this sense, the concept of generic example is a *paramathematical notion* (Brousseau, 1997) as explained in Chapter 2.

In the next chapter I present a synthesis of the analytic findings, together with reflections on strengths and limitations of the research I have undertaken, and potential pedagogical implications of the research.



## 9 Synthesis

The research question which I set out to address was: *What factors constrain students' appropriation of algebraic generality in shape patterns?* The student teachers I observed were in their first academic year in a programme for teacher education with emphasis on mathematics and science subjects. I report from observation of the first encounter the students had with a generalisation perspective on algebra in the mathematics course in the programme on which they were enrolled.

The answers to my research question are structured by the three analytic categories which emerged dialectically between my exploration of the empirical material and engagement with the theory of didactical situation. Hence, the factors interpreted to constrain students' algebraic generalisation of shape patterns are classified into these phenomena: constrained feedback potential in didactical situations; complexity of turning a situation of action into a situation of formulation; and, complexity of operating in the situation of validation.

In this chapter I present my interpretation of relationships between the categories that emerged from the analysis (Section 9.1). Further, I discuss the complexity of students' development of the scientific concept of "mathematical statement" (Section 9.2). Next, I present reflections on strengths and limitations that I perceive in the research I have undertaken (Section 9.3). The chapter closes with a reflection on possible pedagogical implications of the findings (Section 9.4).

### 9.1 Relationships between categories, and dimensions of subcategories

In this section I present my interpretation of relationships between the three categories that emerged from the analysis. The analytic categories are categories of constraints to students' algebraic generalisation of shape patterns. The first category, *Constrained feedback potential in didactical situations*, embraces the second and third categories, *Complexity of turning a situation of action into a situation of formulation*, and *Complexity of operating in the situation of validation*. The first category conceptualises general properties of the milieu for algebraic generality; it refers to the level of design and devolution of didactical situations. The second and third analytic categories conceptualise properties that are specific for situations of formulation and validation of algebraic generality, respectively; they refer to the level of implementation of didactical situations in which the students are supposed to engage.

Situations of action, formulation, and validation are (intentionally) didactical situations where each situation has a feedback potential on

which the success of the situation depends. The first analytic category conceptualises different properties of the didactical milieu for algebraic generalisation of shape patterns. The outcome of my analysis shows how the success of situations of action, formulation, and validation (whether they manage to establish an adequate milieu for the succeeding situation) depends upon the adaptedness of design of tasks, clarity of concepts, and outcome of institutionalisation of previous knowledge. These attributes are subcategories of *Constrained feedback potential in didactical situations*; they are conceptualisations of different properties of the didactical milieu.

The quality of the didactical milieu for situations of formulation and validation (with which the second and third analytic categories deal) depends upon the feedback potential in didactical situations with which the first analytic category deals. Hence, there is a relationship between the first category and the second and third categories. The subcategories of the second category (distinctiveness of recursive and explicit approaches, and engagement with the syntax of algebra) are conceptualisations of different properties of the milieu for formulation of algebraic generality in shape patterns. In an equivalent way, the subcategories of the third category (pertinence of concepts, and validity of reasoning) are conceptualisations of different properties of the milieu for validation of algebraic generality in shape patterns.

The relationships between categories and subcategories are illustrated in Figure 9.1 (on the next page): The diagram illustrates core categories (placed within thick-edged rectangles) and subcategories, the latter with *dimensions* of the property of the subcategory on a continuum. The relationships between the first category and the second and third categories, are illustrated in the diagram in the way the first category is placed in relation to the others: The first category is placed above the two other main categories, with arrows pointing from the subcategories of the first category to the second and third categories. The arrows represent the act of contribution. By this I mean that the subcategories of *Constrained feedback potential in didactical situations* lead to *Complexity of turning a situation of action into a situation of formulation* and to *Complexity of operating in the situation of validation*.

The subcategories in the diagram in Figure 9.1 are neutral categories. Extreme values on the continuum of the dimension of a subcategory define the range of a property of the subcategory. In the following paragraphs I present the extreme values between which the dimension of each subcategory spans.

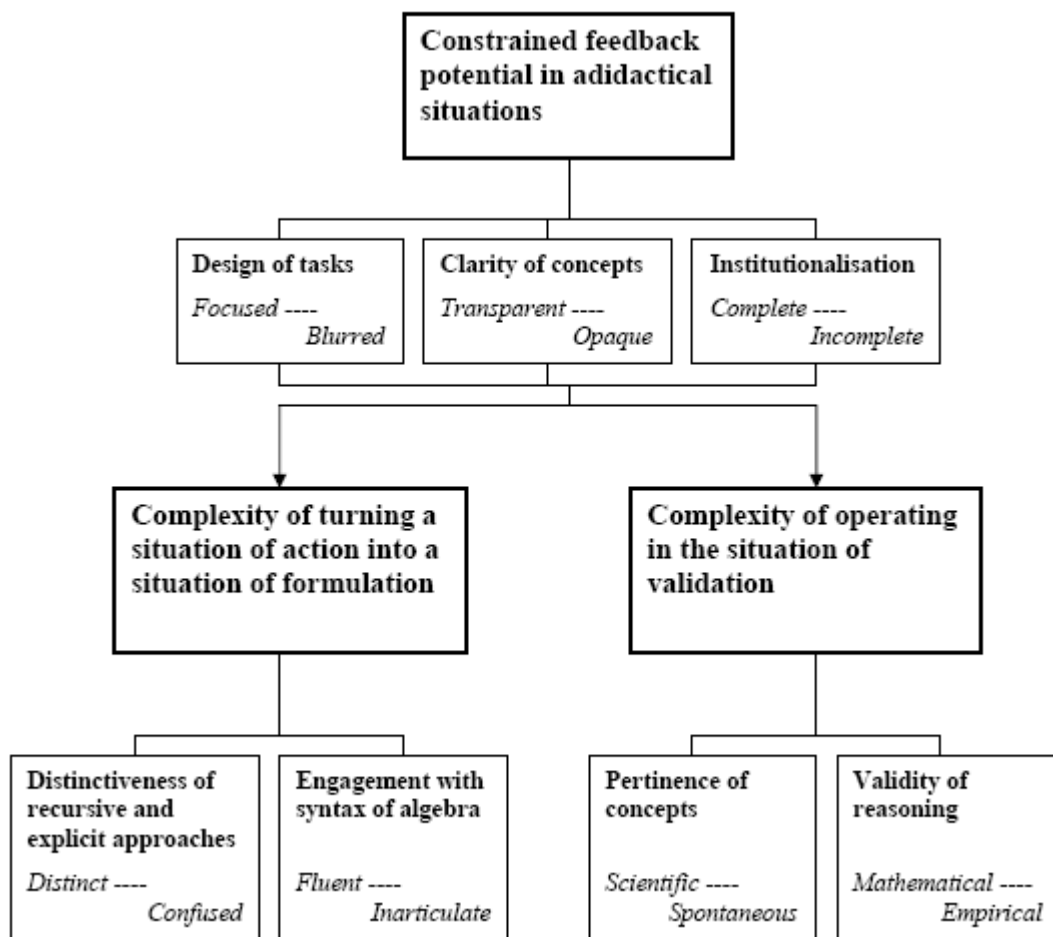

Figure 9.1. Categories (placed within thick-edged rectangles) and subcategories with dimensions (the extreme values of the dimensions are written in italics; the continuum of the dimensions are represented by dotted lines)

Recall from Section 5.1 the introduction of two different types of shape pattern, referred to as arbitrary shape patterns and shape patterns illustrating number theoretical relationships. Some of the dimensions of subcategories are created by the different nature of shape patterns. The extreme values of the dimensions will therefore be explained in the context of two different types of shape patterns: one where the target knowledge is a mathematical statement; another where the target knowledge is a functional relationship. The first shape pattern, referred to as Example 9.1, is the shape pattern presented in Figure 9.2 (on the next page), intended to illustrate that the sum of the first  $n$  odd numbers is equivalent to the  $n$ -th square number. The target mathematical knowledge in this example is a mathematical statement about the generality in the shape pattern, represented in algebraic notation by the equality  $1 + 3 + 5 + \dots + 2n - 1 = n^2$ .

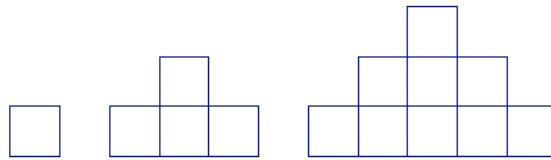

Figure 9.2. The first three elements of a shape pattern which is imagined as continuing to infinity (Example 9.1)

The second shape pattern, referred to as Example 9.2, is the shape pattern presented in Figure 9.3, where the target knowledge is a formula for the numerical value of the  $n$ -th element of the shape pattern. Below follows a presentation of the dimension (with extreme values) of each subcategory.

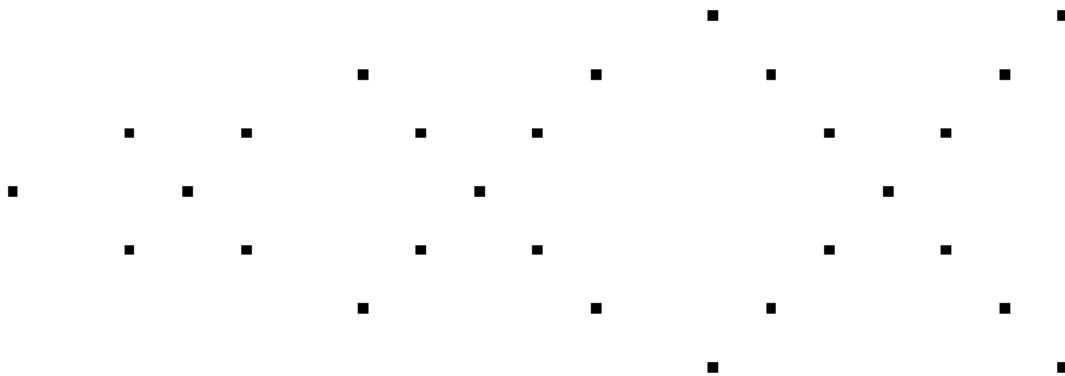

Figure 9.3. The first four elements of a shape pattern imagined as continuing to infinity (Example 9.2)

1) *Adaptedness of design of tasks* spans between *focused* and *not focused* with respect to the target mathematical knowledge: A task design that is focused on the target mathematical knowledge in Example 9.1 concentrates on an *equivalence relation* between odd numbers and square numbers in the first few shapes (that is, encourages algebraic thinking based on formulation of the arithmetic equalities:  $1=1^2$ ,  $1+3=4=2^2$ ,  $1+3+5=9=3^2$ , etc.). A task design that is not focused on the target mathematical knowledge is one that for instance allows the total number of components in each shape to be the focal point, without attention to the structure of the shapes in the pattern. In this case, generality may be proposed as a *functional relationship* between position and member of the sequence mapped from the shape pattern,  $f(n) = n^2$  (which is not the target knowledge).

2) *Clarity of concepts* spans between *transparent* and *opaque* concepts: In Example 9.1 “mathematical statement” is a transparent concept

if it is understood that it is a statement about a mathematical relationship, which needs to be proved, and it is told what the mathematical relationship is *about* (here, odd numbers and square numbers). “Mathematical statement” is an opaque concept if students conceive of it as denoting an expression in mathematical notation, which does not need to be proved, and which could be represented for instance by a function (in Example 9.1:  $f(n) = n^2$ ).

3) *Level of institutionalisation* spans between *complete* and *incomplete* institutionalisation of previous knowledge: In Example 9.1 the target knowledge is the statement of equality; that is, of an equivalence relation between the  $n$ -th square number and the sum of the first  $n$  odd numbers. A complete institutionalisation of previous knowledge about odd numbers (which could be reused in this example) would be that the  $n$ -th odd number can be represented by  $2n - 1$  for  $n \in \mathbb{N}$ . An incomplete institutionalisation (of odd numbers) with respect to reuse in Example 9.1, would be a representation of the  $n$ -th odd number in terms of a recursive relationship (e.g.,  $o_{n+1} = o_n + 2$ , where  $o_n$  denotes the  $n$ -th odd number and  $o_1 = 1$ ). Further, its incompleteness is conditioned by students’ incapacity to transform the recursive relationship into an explicit one.

4) *Distinctiveness of recursive and explicit approaches* spans between *distinct* and *confused* awareness of recursive and explicit approaches to generality: A distinct awareness of recursive and explicit approaches to generality in Example 9.2 would be awareness about how the two approaches are different. It involves knowing that a recursive approach focuses on differences between consecutive members of the sequence mapped from the shape pattern, and that the generality will be expressed in terms of a relationship between consecutive members of the mentioned sequence (i.e., a recursive formula). Further, a distinct awareness involves knowing that an explicit approach focuses on a functional relationship between position and member of the sequence mapped from the shape pattern, and that the generality in this case will be a function (i.e., an explicit formula). A confused awareness of recursive and explicit approaches involves that properties of the two approaches (as described above) are undistinguishable. This may be manifested for instance in the search of an explicit formula on the background of a relationship different from a functional one (e.g., when a formula is attempted to be developed from the differences between numerical value and position of elements of the shape pattern).

5) *Engagement with the syntax of algebra* spans between *fluent* and *inarticulate* involvement: A fluent engagement with the syntax of algebra would comprise the capacity to transform the observation that one

gets the next member of the sequence (Example 9.2) by “adding four to the previous member” (recursively expressed property) into the algebraic explicit expression “ $4n$ ”. An inarticulate engagement with the syntax of algebra would be if the observation that “the next member equals the current member plus four” is translated into the algebraic expression “ $n + 4$ ”, intended to represent the  $(n + 1)$ -th member of the sequence mapped from the shape pattern in Example 9.2.

6) *Pertinence of concepts* spans between *scientific concepts* and *spontaneous concepts*. The concept “generic example” is a scientific concept that would make it possible to establish references between an element of a shape pattern and an explicit formula represented by an algebraic expression. In Figure 9.4 the fourth element of the shape pattern presented in Example 9.2 is used as a generic example to show that the element is composed by one dot (in the middle) plus four “arms”, each with one dot less than the position of the respective element in the pattern.

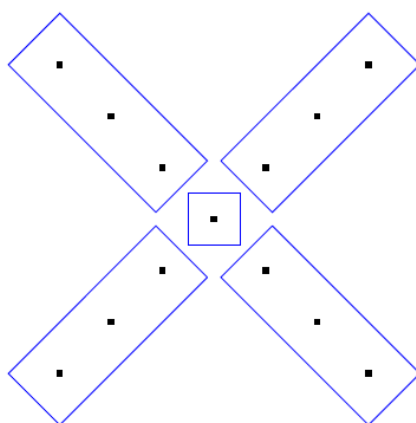

Figure 9.4. The fourth element of the shape pattern presented in Example 9.2, used as a generic example

The point is to make references between the elements of the shape pattern and an explicit formula which represents the regularity of the pattern,  $f(n) = 1 + 4(n - 1)$ . The concept “structure”, used by a teacher in connection with justification of a formula for the general member of a sequence mapped from a shape pattern, would be a spontaneous concept if it is understood by students in an everyday sense and (for them) lacks clarity of its intention (which might be communicated for instance by use of the concept generic example).

7) *Validity of reasoning* spans between reasoning that is *mathematically valid* and reasoning that is *mathematically invalid* (referred to in the diagram as “mathematical ---- empirical”). Reasoning that is mathe-

mathematically valid in justification of the formula in Example 9.2,  $f(n) = 1 + 4(n - 1)$ , would be reasoning by showing references between the partitions of a generic example (e.g., Figure 9.4) and symbols in the algebraic expression which constitutes the formula. Reasoning which is empirical (and mathematically invalid) would be reasoning by claiming that the formula is correct by observing that one gets the right values if evaluating the formula when  $n$  equals one, two, three, four, and up to a finite position.

Figure 9.1 above presented categories of constraints to students' algebraic generalisation of shape pattern which might prove useful to any teacher or teacher educator in analysing didactical situations in which students engage with mathematical tasks on algebraic generalisation. The diagram is a neutral setting out of the categories and dimensions of my study. The analysis of the transcripts from the groups of students that I have studied leads me to assert that: The tasks were not sharply focused on the mathematics (Section 6.1); concepts with which the students were supposed to engage lacked clarity (Section 6.2); institutionalisation of the mathematics was left incomplete (Section 6.3); there was confusion with respect to distinctiveness of recursive and explicit approaches to generality (Section 7.1); there were problems with the syntax of algebra (Sections 7.1 and 7.2); everyday concepts did not interact adequately with scientific concepts in explanation of the notion of mathematical proof (Section 8.1); and, students were reasoning empirically rather than mathematically (Section 8.2). These assertions are illustrated in Figure 9.5 (on the next page). They are findings which are answers to my research question about what factors constrain students' appropriation of algebraic generality in shape patterns.

I want to stress that these constraints became evident after many hours of painstaking analysis of transcripts or recordings. In the regular course of events, teachers have neither the opportunity nor time to make such an analysis. My conjecture is (and I cannot validate this from my data) that the constraints I have observed, and perhaps others, are rather commonplace in mathematics teaching at all levels. As noted by the UK Committee of Inquiry into the teaching of mathematics in schools (Cockcroft, 1982), mathematics is a difficult subject both to teach and to learn. These weaknesses in the milieu that have just been listed draw into sharp focus some of the specific issues that make teaching mathematics so challenging and the significance of thorough epistemological analysis.

According to the epistemological analysis presented in Chapter 5, the target mathematical object in tasks on algebraic generalisation of shape patterns is either a formula for the general member of the sequence mapped from the shape pattern, or a mathematical statement that expresses a number theoretical relationship mapped from the shape pattern.

“Formula” and “mathematical statement” are both scientific (mathematical) concepts. In the next section I explain how the students’ formulation of a mathematical statement is constrained in the didactical situation.

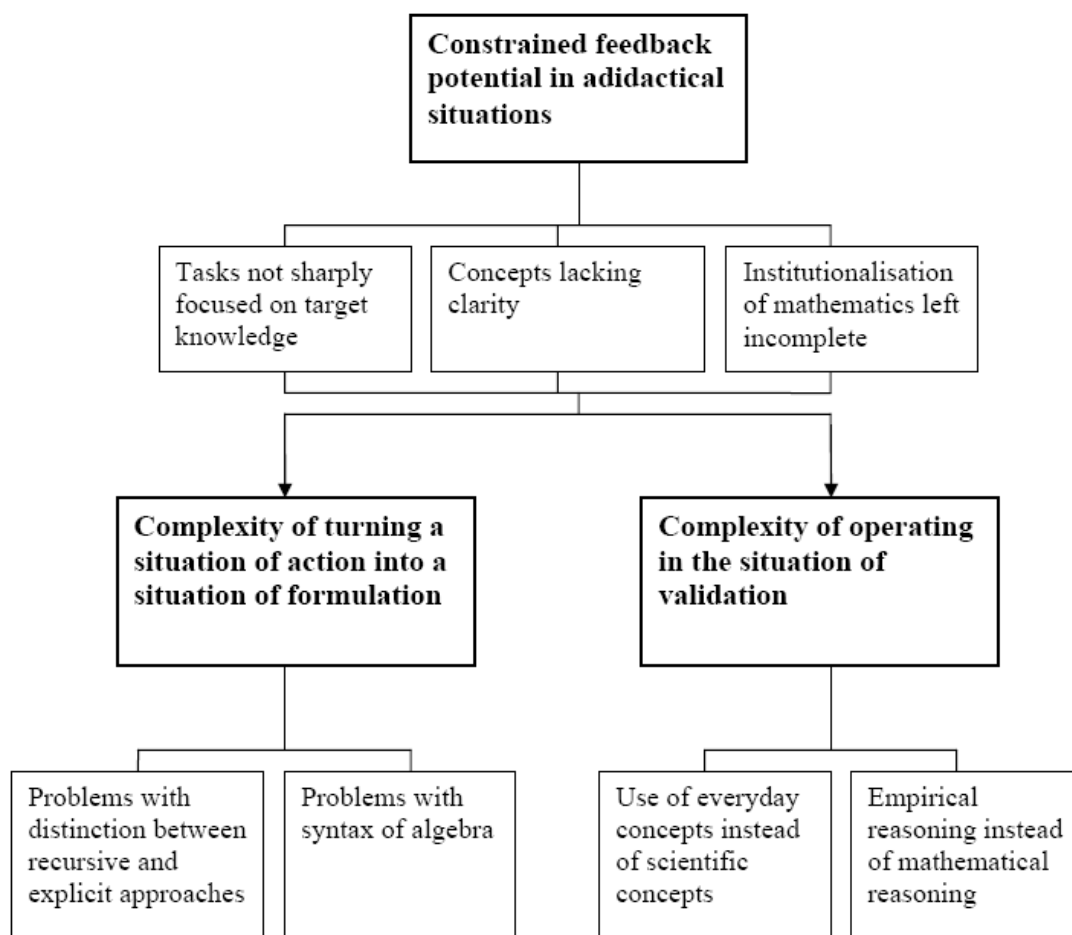

Figure 9.5. Relationships between categories and subcategories as developed through analysis of the empirical material

## 9.2 Complexity of developing the scientific concept “mathematical statement”

The concept of mathematical statement is used in Task 3 and Task 4 (see Appendix A) as a mediational means to refer to the mathematical object aimed at (the algebraic generality that represents the regularity of the respective shape pattern). The first parts of the mathematical tasks (Tasks 3a, 3b, 3c, and Tasks 4a, 4b) are designed to provide the students with experiences with invariant structures in shape patterns. These parts I interpret as intended to activate students’ spontaneous concepts, which in the last part of the tasks (Task 3d, Task 4c) are intended to be saturated with the scientific concept of mathematical statement. The analysis shows, however, how the milieu for formulation and validation of a mathematical statement is constrained: First, there are obstacles in terms



of a constrained feedback potential in didactical situations (first analytic category). Second, there are constraints in terms of complexity of formulating in mathematical notation what they have experienced and expressed in everyday or spontaneous concepts (second analytic category). Third, there are constraints in terms of complexity of mediating the idea of mathematical proof (third analytic category). In Sections 9.2.1, 9.2.2, and 9.2.3 I explain how these constraints are manifested in the didactical situation that aims at the students' formulation of a mathematical statement about number theoretical relationships.

In the next section I explain how the feedback potential in didactical situations is constrained and constitutes constraints to the formulation of a mathematical statement expressed in algebraic notation.

### **9.2.1 Formulation of a mathematical statement constrained by features of the milieu**

In Chapter 6 I presented how the feedback potential in didactical situations is constrained. The identified constraints can be interpreted as weaknesses in the milieu for formulation of a mathematical statement in three senses: First, there is a weakness in the objective milieu caused by the design of the tasks: The students produce adequate solutions to sub-tasks but these solutions do not prepare a milieu for the formulation of a mathematical statement (see Section 6.1.1); and, the idea of proof as intended by the teacher is not transparent for the students who treat the proof assignment as a new generalisation task which they solve by using naïve empiricism (see Section 6.1.2).

Second, there is a weakness in the milieu for formulation of a mathematical statement caused by missing clarification of the concepts of mathematical statement and generic example: The students establish a formula for the general member of the actual sequence instead of a mathematical statement about a relationship between odd numbers and square numbers (see Section 6.2.1); the teacher uses a generic example without the students' awareness of its general meaning (see Section 6.2.2); and, Topaze effects are produced because the students have made the statement of a function instead of a conjecture about number theoretical relationships (see Section 6.2.3).<sup>109</sup>

---

<sup>109</sup> The students have made the statement of a function (the general member of a sequence is expressed as a function of its position). This is a statement of quantity based on empirical

Third, there is a weakness in the milieu for formulation of a mathematical statement caused by incomplete institutionalisation of previous knowledge: The symbolic representation of an odd number is not reusable for the students because it originates from a Topaze effect and has not been institutionalised (see Section 6.3.1); the students formulate a mathematical statement which is inadequate as a consequence of incomplete institutionalisation of syntax and notation for recursive relationships (see Section 6.3.2); and, the students are inhibited from following the teacher's explication because it presupposes prior knowledge which the students do not have (see Section 6.3.3).

In the next section I explain how the students' everyday concepts about invariant structures in a shape pattern are complicated to transform into a mathematical statement in algebraic notation.

### **9.2.2 Complexity of transforming experiences with invariant structures expressed in everyday concepts into the scientific concept of a mathematical statement**

The students' formulation in scientific concepts of what they have expressed in everyday concepts is constrained in two senses. First, there is a constraint caused by the students' confusion of recursive and explicit approaches to the general member of the sequence mapped from the shape pattern: The students' experiences with a recursive formula are used inadequately to find an explicit formula (See Section 7.1.1); a Jourdain effect is produced when the teacher interprets a functional relationship in a student's description of properties in spontaneous concepts (see Section 7.1.2); the students accept an incomprehensible difference because they confuse an explicit formula with a recursive formula (see Section 7.1.3); the students' and teacher's different approaches (recursive vs. explicit) are unmarked by both parts (see Section 7.1.4); and, the students' have difficulties in transforming recursively expressed properties into an explicitly expressed mathematical statement (see Section 7.1.5).

Second, there is a constraint to the formulation of a mathematical statement caused by expectations with respect to the syntax of the mathematical object aimed at: The students' desire to write an indeterminate sum (the  $n$ -th partial sum of an arithmetic series) in an easier way is an indication of the need (and potential) for knowledge about arithmetic

---

facts (counting components of the elements). It is not a theorem that needs to be justified by a mathematical proof.

series (see Section 7.2.1); the students do not benefit from the teacher's intervention because they have limited knowledge about syntax of formulae (see Section 7.2.2); and, the epistemological properties of the relationships between natural numbers, odd numbers, and square numbers (as illustrated in the shape pattern) expressed in spontaneous concepts by the students are complicated to transform into the scientific concept of a mathematical statement in symbolic notation (see Section 7.2.3).

In the next section I explain how it is complicated for the teacher to communicate and for the students to understand the idea of mathematical proof.

### **9.2.3 Complexity of mediating the idea of (and need for) mathematical proof**

As referred to in Section 5.1.5, mathematical statements, which are the main currency of the discipline of mathematics, are defined by the feature that they are established by means of a mathematical proof (Gowers, 2008). This requirement of the mathematical object aimed at in Task 3 and Task 4 is a feature which involves an attitude of mathematical proof. There are constraints in the situation of validation caused by the distance between the students' everyday meaning of justification (manifested as reasoning by naïve empiricism) and the rigorous requirements of a mathematical proof. The activity in the situation of validation is constrained in two senses. First, there is a constraint in the milieu for validation related to the use of concepts which have both an everyday and a scientific connotation: The teacher uses the concepts "structure" and "structural relationships" when he tries to make the students focus on the regularity (relationship between position and number of components based on geometrical configuration) of the shape pattern (see Section 8.1.1); and, the teacher uses the concepts "plane" and "level" when he attempts to explain the distinction between empirical reasoning and structural reasoning (see Section 8.1.2).

Second, there is a constraint in the milieu for validation of a conjectured mathematical statement caused by the students' unawareness of the inadequacy of empirical reasoning: The students are unaware of the importance of how a formula or mathematical statement is derived (see Section 8.2.1); and, it is complicated to explain and understand the disparity between two formulae that are syntactically identical but derived in different ways (by empirical versus structural reasoning; see Section 8.2.2).

In the next section I use Vygotsky's theory to explain how the concept of mathematical statement fails to be institutionalised.

### 9.3 Degenerated situation of institutionalisation

As outlined in Section 2.6.2 with reference to Daniels (2001) and Karpov (2003), there is a fundamental need for instruction in the development of scientific concepts. The insights provided by the research reported in this dissertation are relevant with respect to the development and use of the concept of mathematical statement in the context of shape patterns: It gives insights into the outcome of an adidactical situation aimed at algebraic generalisation when students attach the everyday meaning of words they encounter (e.g., “statement”). Teachers<sup>110</sup> (as did the teacher in the observed lessons) may want to spare students from esoteric mathematical definitions and use what is believed to be more comprehensible terms (e.g., avoid the notion “theorem”). However, in so doing, teachers may inhibit students from learning the characteristics of the concept at play and potentially leave students to use didactical reasoning instead of mathematical reasoning. The students in the observed groups were seen to search for didactical markers (in the tasks and in the teacher’s utterances) when they solved the tasks because they were not familiar with the definition of “mathematical statement” (see Section 6.2.1). The concept of mathematical statement was not institutionalised, either in or after the observed lessons. As a consequence of missing knowledge about the mathematical object aimed at (that a mathematical statement needs to be proved), the students did not appropriate the number theoretical relationships aimed at.

In the observed episodes the term “mathematical statement” was questioned by the students (Task 3 and Task 4). The teacher responded in a way quite common for teachers (Mason, 1996): he presented an example (one for each task) which I interpret to be generic for him but not for the students. This terminated the possibility of the notion “mathematical statement” to become “the object of communicative activity” (Minick, 1987, p. 27), a function of the word which leads to development of scientific concepts (Vygotsky, 1934/1987). Communication about a mathematical concept is exactly the enterprise of a situation of institutionalisation (see Section 2.4.3 and Section 2.6.2). Institutionalisation involves that the teacher takes responsibility for an object of teaching and identifies its status as manifested in the processes and knowings developed by the students in situations of action, formulation, and valida-

---

<sup>110</sup> Here and in the following, I include myself in the noun “teachers”.

tion. It is important that the student takes into account the object of knowing, and that the teacher takes into account the student's learning. This double recognition is defined by Brousseau (1997) to be the object of institutionalisation.

Institutionalisation of knowledge developed by the groups took place within the collaborative lessons. The teacher interacted with the groups, on the students' as well as on the teacher's own initiative. There were no whole-class lessons where knowledge collected from the small-group collaboration were compared, decontextualised, and reformulated in conventional notation to become cultural, reusable knowledge. This constitutes a possible weakness in the design of the teaching units aimed at algebraic formulae or mathematical statements representing generality in shape patterns (see Section 6.5.3).

#### *What is researched and what is not researched*

The research question set out to expose constraints in the teaching-learning situation. The analysis of data reported in Chapters 6, 7 and 8, and summarised above, has drawn attention to a number of constraints seen through the lens of the theory of didactical situations. It would be very easy to conclude from the analysis that nothing positive emerged from the teaching-learning during the observed classes. Such a conclusion would be inappropriate because the research did not set out to expose the learning that occurred. My purpose in this research was to look deeply into didactical situations so that I might be more aware of constraints that may arise in my own practice, and to report these constraints so that other teachers might learn alongside me. The students I observed, who very generously allowed me to look into their collaborative engagement with mathematical tasks, are not exceptional, in any way – apart from their willingness to be exposed in research such as my own. The teachers involved are my closest colleagues, for whom I have the highest regard as mathematics educators. Their willingness to allow me to explore constraints that emerged in didactical situations in their classrooms reveals their concern to contribute to the development of our practice. We have learned together in this research enterprise and it is hoped that their readiness for their practice to be exposed in this report will support other dedicated teachers in learning more about their own practice.

In the next section I discuss strengths and limitations of the research reported in this dissertation.

## **9.4 Strengths and limitations of the reported research**

Reliability and validity, which are important criteria for evaluating the quality of quantitative research, are not indisputably applicable to qualitative research (Bryman, 2001). Yvonna S. Lincoln and Egon G. Guba

(1985) propose *trustworthiness* as a criterion for evaluating a qualitative study. They draw on Guba (1981) when they propose that trustworthiness has four criteria, each of which has an analogous criterion in quantitative studies: *credibility*, which parallels internal validity; *transferability*, which parallels external validity; *dependability*, which parallels reliability; and, *confirmability*, which parallels objectivity.

The research design and methods I have chosen to ensure trustworthiness can be summarised in the following points: First, I have researched a “regular” class in the teacher education programme; nothing special has been done regarding content or approach for my inquiry. Second, there has been minimum disruption of routine; special arrangements have been made on ethical grounds (choice of participants) and on practical grounds (choice of participants and room). Third, a non-intrusive approach has been used in that there has been no engagement between researcher and participants. Fourth, I was familiar with the routine; I did not need to acclimatise myself to the context. Fifth, the analysis is based on a dialectic between theory and data; theory has been used to explore the data, and data has been used to test the theory. Sixth, results from the analysis have been open to critical peer review through presentations at conferences and seminars, and through peer reviewed publications.

In the following sections I examine more closely the research reported in this dissertation against the four criteria of trustworthiness presented above.

#### **9.4.1 Credibility**

Credibility is about whether the reported research “rings true”. As stated above, Lincoln and Guba (1985) propose that credibility parallels internal validity in quantitative studies. Joseph A. Maxwell (1992) claims that *understanding* is a more fundamental concept for qualitative research than validity. He distinguishes among different types of understanding that may emerge from a qualitative study: descriptive understanding addresses what happened in specific situations; interpretive understanding addresses what it meant to the people involved; theoretical understanding addresses the theoretical constructs (and their relationships) used or developed by the researcher; and, evaluative understanding involves the application of an evaluative judgement of the objects under study (Maxwell, 1992). The understanding developed through my study is theoretical in that it goes beyond concrete description and interpretation and explicitly addresses the concepts of the theory of didactical situations in mathematics: The function of my account is, as well as a description and interpretation, an *explanation* of the phenomenon under study (constraints to students’ algebraic generalisation of shape patterns). The analytic categories that emerged from the analysis are conceptualisations of

key aspects of the data, and the dissertation presents an interpretation of relationships between the categories (Section 9.1).

Strengths of the reported research I claim to be the following: First, I have studied a *regular class* which is minimally disturbed from routine (see Section 4.3). I have used a non-intrusive approach; there has been no didactic engagement between researcher and participants during observation. Second, in writing this report, the aim has been to provide the reader with “thick description” (Geertz, 1973) that will enable him/her to recognise the context (see Section 4.3). Third, I have studied didactical situations in mathematics (more specifically, relationships between the teacher, the students, and the target mathematical knowledge). Hence, there is coherence between theory and data. Fourth, I have done a *methodological triangulation* (as explained in Section 4.4.3). The analysis of the transcript data draws on two other sources: first, on the epistemological and didactical analyses of the mathematics potential in the tasks with which the students engaged; second, it draws on conversations with the teacher who has designed the tasks. Fifth, mathematics teacher educators and researchers in mathematics education have been engaged in peer critique. This has taken place through presentations at conferences and seminars<sup>111</sup>, and through peer reviewed publications (Måsøval, 2006, 2007, 2009; Goodchild, Jaworski, & Måsøval, 2007). Peer critique is also provided by my two supervisors. In addition, aspects of the theoretical foundation of the study have been discussed with other researchers in mathematics education.<sup>112</sup>

A weakness of the chosen methodology is the inevitability of disturbance. The context is changed because the participants know that they are part of a research project, and that they are being recorded. In social research this phenomenon is referred to as the *Hawthorne effect*, “the fact that any intervention tends to have positive effects merely because of the attention of the experimental team to the subjects’ welfare” (Brown, 1992, p. 163). As a teacher and teacher educator I have found it chal-

---

<sup>111</sup> Conferences: PME 28 (2004); NORMA 05 (Forth Nordic Conference on Mathematics Education, 2005); NORMA 08 (Fifth Nordic Conference on Research in Mathematics Education, 2008). Seminars with researchers in mathematics education: Sør-Trøndelag University College (2006); University of Agder (2005, 2008); Loughborough University (2007); and, Norwegian University of Science and Technology (2010).

<sup>112</sup> These include Nicolas Balacheff, Guy Brousseau, Stephen Lerman, Marie-Jeanne Perrin-Glorian, and Carl Winsløw.

lenging to don the mantel of a classroom researcher and avoid being judgemental. However, the analysis is based on what is observed. I have included a lot of data to enable the critical reader to test my interpretations and assertions and reach his/her own conclusions.

#### **9.4.2 Transferability**

Transferability is about whether the research findings apply to other situations. A quality of the chosen methodology is that the analysis is based on strong theoretical foundation that has enabled *analytic generalisation*. This concept is explained by William A. Firestone (1993) as “extrapolation using a theory” (p. 16). I have provided an extended introduction to the theory of didactical situations in mathematics. This is done to familiarise the reader with the theoretical concepts used and to make it easier for him/her to judge whether the theory is used appropriately in an analytic generalisation. The reason for including a lengthy explication of Brousseau’s theory is that many find this theory difficult to understand, a stance acknowledged by Sierpinska (2005).

The analytic generalisations presented in this dissertation are in the form of *fuzzy generalisations* (Bassey, 1999), as explained in Section 4.2.1. The intention with the research reported here is two-fold: First, it is to report from my educational case study what factors constrain students’ establishment of algebraic generality in shape patterns. Second, it is to explore the power of the theory of didactical situations in mathematics to expose critical features of teaching and learning mathematics on a teacher education programme.

The thick description provided enables a type of extrapolation that Firestone (1993) refers to as *case-to-case translation*. It is up to the reader to make a judgement about whether the groups I describe fit their own context. In this way, responsibility for application to another case is passed from the researcher to the reader, which should be facilitated by the thick description of the context that has been provided. According to Firestone (1993), the claims of a study using case-to-case translation, while legitimate, are weaker than when generalisation is done by extrapolation from sample to population, or by extrapolation using a theory.

A limitation of the chosen methodology is that there have been changes in the teacher education programme since the data were collected. This could mean that similar groups of students would not appear. My research will in this case be historically bound, held fast like a “fly in amber”. However, I want to assert that the general issues highlighted by the theoretical perspective transcend minor historical changes in the constitutional order. It is easy to change the curriculum; it is not so easy to transform students or teachers.



### 9.4.3 Dependability

Dependability is about whether other analysts would make the same interpretations and assertions. A strength of the reported research is the amount of data reproduced in the report, and that the interpretations have been open to critical peer review (as explained in Section 9.4.1). In writing this report, my intention has been to provide sufficient examples from the data to allow other researchers to judge the strength of the interpretations made and allow them to exercise their own critical judgement (whether the interpretations presented in the report are reliable given the collected data). In addition, in Chapter 4, I have described in detail how the data were collected, how decisions were made throughout the inquiry, and how analytic categories were derived. Sharan B. Merriam (2009) claims that such descriptions are preconditions for an *audit trail* procedure to be accomplished. An audit trail is a way of ensuring what Lincoln and Guba (1985) refer to as *dependable data*.

A weakness of the chosen methodology is the adherence to one theory (Brousseau's theory of didactical situations in mathematics, augmented by Vygotsky's theory of concept development). Other theoretical perspectives might produce different interpretations. However, I have provided one interpretation that could be used by teachers to examine their own practice and learning opportunities of their students.

### 9.4.4 Confirmability

Confirmability is about whether the findings would be consistently repeated if the study were replicated in the same (or similar) context with the same (or similar) participants. Miles and Huberman (1994) explain that confirmability is about "relative neutrality and reasonable freedom from researcher biases – at the minimum, explicitness about the inevitable biases that exist" (p. 278). My account of the ontological and epistemological assumptions that underlie the inquiry (Section 4.1), together with the epistemological and didactical analyses of the mathematics potential in the tasks with which the participants engaged (Chapter 5), are made to make my assumptions and preconceptions explicit.

A quality of the chosen approach is that the data could be re-analysed by other researchers if wanted. With respect to the classroom observations, there are ethical regulations that prevent others from seeing the video recordings (The National Committee for Research Ethics in the Social Sciences and the Humanities, 2006). The transcript data, however, are available for re-analysis. The mathematical tasks used in the observed didactical situations are reproduced in the dissertation, and hence available for other researchers to make their own epistemological and didactical analyses. Transcripts and summaries from conversations with the teacher who designed the tasks are also available for use in a re-analysis by others. Further, as mentioned in the previous section, the

study's general methods and procedures are described explicitly and in detail. Furthermore, data reduction and analysis products are available for inspection; these include theoretical memos and summaries such as condensed notes.

A weakness of the chosen research design is that it is impossible to replicate because reproduction of the same context is unattainable; every teaching situation is unique. But it would be possible for a teacher or researcher to record group activity with teacher interaction and subject it to the same type of analysis. The points on the dimensions of categories might be different, but it would be possible to confirm the categories as providing a description of the data.

In the next section I reflect on possible pedagogical implications of the research reported in this dissertation.

## 9.5 Potential pedagogical implications

As explained in Section 5.2.3 there is a two-fold purpose of students' engagement with algebraic generalisation of shape pattern: One is to provide a context for algebraic generalisation where the aim is to promote students' algebraic thinking. This can be considered as an approach to algebra through pattern generalisation. The other is to lead students to experience patterns as mathematical structures as an aim in itself, where the focus is on infinite processes and generalisation. In this perspective, algebra is a mediational means to represent invariant structures in the patterns. The potential of pattern generalisation as an entrance to algebraic knowledge is noted by Miriam Amit and Dorit Neria (2008) who write:

The importance of pattern problems – linear, and particularly non-linear ones – lies in their extensive mathematical potential. They not only encourage generalization, they also require students to pool their existing knowledge resources and build upon them. Thus, they are a gateway to new knowledge, in this case, algebraic knowledge. (p. 128)

### *Different nature of the target mathematical knowledge*

In my study there are two kinds of mathematical objects which are potential outcome of algebraic generalisation of shape patterns: one is a functional relationship; the other is a theorem. These mathematical objects correspond to different types of shape patterns (see Section 5.1.3 and Section 6.5.2). One type can be referred to as *arbitrary* shape patterns whose generalisation points at a formula for the  $n$ -th member of the sequence mapped from the shape pattern, where the formula is given as a function of  $n$ . The other type can be referred to as *relational* shape patterns whose generalisation points at a theorem about general numerical relationships. The theorem will be a mathematical statement about

equivalence of two algebraic expressions for the numerical value of the general element of the shape pattern.

It is relevant for mathematics teachers<sup>113</sup> to take the different nature of the target knowledge into consideration when they design teaching units aimed at algebraic generalisation of shape patterns. Whereas a formula (in terms of a function) is inevitably connected to the presented shape pattern, a mathematical statement is decontextualisable in the sense that it has relevance beyond the shape pattern from which it originates. Institutionalisation of the knowledge in the case when algebraic generalisation of a shape pattern aims at a formula is not institutionalisation of the formula per se. It is institutionalisation of how the invariant structure of the pattern is interpreted into arithmetic relations and how these in turn are generalised algebraically in terms of a formula (for the general member). The cultural, reusable knowledge in this case is the nature of the relationship between the algebraic expression and its referent (a generic element of the pattern). On the other hand, institutionalisation of the knowledge in the case when algebraic generalisation aims at a mathematical statement involves decontextualisation of the mathematical statement from the shape pattern on the basis of which it is developed. The cultural, reusable knowledge in this case is algebraic generalisation of arithmetic relations between sequences of numbers.

The challenge that faces mathematics teachers at all levels is to design a milieu that enables students to experience the intended mathematical challenge and appropriate the desired mathematical knowledge. The analytic categories presented in Figure 9.1 (Section 9.1) could be used by mathematics teachers in preparing teaching units aimed at algebraic generalisation. The core categories, which emerged from exploration of the empirical material, indicate two types of constraints which could be anticipated in didactical situations aiming at students' algebraic generalisation: The first type of constraint deals with how students' "free production of knowledge"<sup>114</sup> in a teaching-learning situation can be constrained. That is, how the feedback potential in didactical situations can be limited. The other type of constraint deals with the complexity of different

---

<sup>113</sup> In the following I include teacher educators of mathematics in the noun "mathematics teachers".

<sup>114</sup> "Free production of knowledge" refers to knowings developed by students as a response to a mathematical problem given to them, without didactical reasoning and without interventions by the teacher.

phases in the teaching-learning situation; that is, situations of formulation and validation. In the following paragraphs I explain in more detail potential pedagogical implications of the analytic findings.

*Generalisation process focused on the target knowledge*

The reported research reveals that when we (mathematics teachers) design tasks on algebraic generalisation of shape patterns, we have to be rather cautious to ensure that the tasks are focused on the target mathematical knowledge. The target knowledge (whether it is a functional relationship or a theorem) is algebraic generalisation of arithmetic relations arising from the elements of the shape pattern. For epistemological reasons, the focus in the tasks therefore should be on those arithmetic relations, rather than on just the total number of components of the elements.

I conjecture that the process of decomposition and the concept of generic example, as outlined in Chapter 5, would be useful for teachers in communicating ideas of structure and relationships between variables. Decomposition can help to focus on a relationship between the algebraic expression (of a formula or a mathematical statement) and its referent (a generic element). This could help to avoid an isolated focus on the total number of components of elements, an unhelpful focus which is likely to be accompanied by a guess-and-check approach to a formula.

*Recursive and explicit approaches*

Several researchers recommend that students should be familiar with both recursive and explicit strategies for algebraic generalisation of shape patterns (e.g., Dörfler, 2008; Lannin et al., 2006). Based on findings related to constraints in students' generalisation processes reported in this dissertation, I suggest that it is important to let students experience and express the different nature of the two approaches, and how the outcomes of the two diverge. This includes developing awareness about the different relationships expressed by recursive and explicit formulae or mathematical statements, and notation for the two types. This includes that students should develop awareness about the different nature of the two approaches: that a recursive approach analyses the relationship between members in the sequence mapped from the shape pattern (i.e., it analyses the sequence as the position in the sequence increases); and, that an explicit approach analyses the relationship between position and member of the sequence in this position (i.e, it analyses a single generic element of the sequence).

In the observed lessons, which comprised these students' first experiences with algebraic generalisation and shape patterns in this course, there were five manifestations of confusion of recursive and explicit approaches to generality. This leads me to suggest that the two different approaches should be introduced with some distance in time. It is also important that teachers design the milieu in accordance with the target

mathematical object. That is, that there is feedback provided which tells the students whether they have developed an appropriate (recursive or explicit) formula or mathematical statement. An a priori analysis of the mathematics potential in tasks done by the teacher will give insights into the issue of alternatives; that is, whether the solution can be given both as a recursive and as an explicit relationship. This is important for a teacher's possibility to notice and respond appropriately to students' contributions.

### *An attitude of proof*

With respect to situations of validation, my research can be helpful in the way it points at the necessity of developing students' awareness of the distinction between empirical reasoning and mathematical reasoning. Further, it points at the intricacy of explaining the inadequacy of empirical reasoning, and shows how concepts like "structure", "higher plane" and "superior level" fall short in explaining what it takes to justify an assertion mathematically. I conjecture that the concept of "generic example" would be beneficial in situations of validation to mediate between a shape pattern and the structural relationships it is intended to illustrate. A generic example can be used to make explicit the reasons for the truth of an assertion. This applies both when the assertion is a formula for the general member of the sequence mapped from an arbitrary pattern, and when the assertion is a theorem about equivalence of two general expressions mapped from a relational pattern. The above points at the necessity of students being taught what distinguishes formal, rigorous mathematical reasoning from empirical reasoning. We cannot expect students to discover or adapt an attitude of mathematical proof for themselves, no matter how well the situation of validation is designed.

A potential pedagogical implication of another character is the theoretical foundation for a pattern based approach to algebra provided in Chapter 3. This outline could be useful for mathematics teachers and teacher educators as a foundation for organisation and facilitation of students' learning of algebra through pattern generalisation.

## **9.6 Closing remark**

Based on the experience with the research reported here, I will make the point that an a priori epistemological analysis of mathematical knowledge, while necessary, is not adequate for assessing the epistemological constraints of mathematical knowledge in a didactical situation. The knowledge exposed in this report is a component of epistemological knowledge of mathematics in social learning settings in the way that it is a result of analyses of teaching-learning situations drawing on epistemological analysis of the mathematical knowledge at stake. Steinbring (1998) claims that this kind of epistemological knowledge

is not a systematized, canonical knowledge corpus which could be taught to future teachers in the way of a fixed curriculum. Rather, the epistemological knowledge consists of exemplary knowledge elements as it refers to case studies of analyses of teaching episodes or of interviews with students, and comprises historical, philosophical, and epistemological conceptual ideas. (Steinbring, 1998, p. 160)

The case study reported in this dissertation is about the interplay between the didactical constraints of the communicative process aiming at students' appropriation of algebraic generality, on the one hand, and the epistemological structure of this target mathematical knowledge (algebraic generality and related concepts), on the other. The knowledge exposed in this report, supported by Steinbring's (1998) notices about elements of epistemological knowledge for mathematics teachers, offers guidance for the way I, as a teacher educator of mathematics, will work with student teachers: It is important for student teachers to analyse teaching-learning situations from the perspective of an epistemological analysis of the mathematical knowledge in play.

## 10 References

- Aleksandrov, A. D. (1999). A general view of mathematics. In A. D. Aleksandrov, A. N. Kolmogorov, & M. A. Lavrent'ev (Eds.), *Mathematics: Its content, methods and meaning* (Vol. 1, pp. 1-64). Mineola, NY: Dover Publications. (Original work published 1963)
- Al-Khwārizmī. (n.d.). In *Encyclopædia Britannica online*. Retrieved from <http://www.britannica.com/EBchecked/topic/317171/al-Khwarizmi>
- Amit, M., & Neria, D. (2008). "Rising to the challenge": Using generalization in pattern problems to unearth the algebraic skills of talented pre-algebra students. *ZDM – The International Journal on Mathematics Education*, 40, 111-129.
- Artigue, M. (1992). Didactic engineering. In R. Douady & A. Mercier (Eds.), *Research in didactique of mathematics: Selected papers* [Extra issue of Recherches en Didactique des Mathématiques] (pp. 41-66). Grenoble, France: La Pensée Sauvage.
- Artigue, M. (1994). Didactical engineering as a framework for the conception of teaching products. In R. Biehler, R. W. Scholz, R. Strässer, & B. Winkelmann (Eds.), *Didactics of mathematics as a scientific discipline* (pp. 27-39). Dordrecht, The Netherlands: Kluwer.
- Artigue, M., & Perrin-Glorian, M.-J. (1991). Didactic engineering, research and development tool: Some theoretical problems linked to this duality. *For the Learning of Mathematics*, 11(1), 13-18.
- Bachelard, G. (2001). *The formation of the scientific mind: A contribution to a psychoanalysis of objective knowledge* (M. M. Jones, Trans.). Manchester, UK: Clinamen Press. (Original work published 1938)
- Balacheff, N. (1988). Aspects of proof in pupil's practice of school mathematics. In D. Pimm (Ed.), *Mathematics, teachers and children* (pp. 216-235). London, UK: Hodder & Stoughton in association with Open University.
- Balacheff, N. (1991). The benefits and limits of social interaction: The case of mathematical proof. In A. J. Bishop, S. Mellin-Olsen, & J. van Dormolen (Eds.), *Mathematical knowledge: Its growth through teaching* (pp. 175-192). Dordrecht, The Netherlands: Kluwer.

- Balacheff, N. (1993). Artificial intelligence and real teaching. In C. Keitel & K. Ruthven (Eds.), *Learning from computers: Mathematics education and technology* (pp. 131-158). Berlin, Germany: Springer-Verlag.
- Balacheff, N. (2001). Symbolic arithmetic vs. algebra: The core of a didactical dilemma. In R. Sutherland, T. Rojano, A. Bell, & R. Lins (Eds.), *Perspectives on school algebra* (pp. 249-260). Dordrecht, The Netherlands: Kluwer.
- Bassey, M. (1999). *Case study research in educational settings*. London, UK: Open University Press.
- Bauersfeld, H. (1988). Interaction, construction and knowledge: Alternative perspectives for mathematics education. In D. A. Grouws, T. J. Cooney, & D. Jones (Eds.), *Effective mathematics teaching* (pp. 27-46). Reston, VA: NCTM & Lawrence Erlbaum.
- Becker, J. R., & Rivera, F. (2005). Generalization strategies of beginning high school algebra students. In H. Chick & J. L. Vincent (Eds.), *Proceedings of the 29th Conference of the International Group for the Psychology of Mathematics Education* (Vol. 4, pp. 121-128). Melbourne, Australia: PME.
- Becker, J. R., & Rivera, F. (2006). Establishing and justifying algebraic generalization at the sixth grade level. In J. Novotná, H. Moraová, M. Krátká, & N. Stehlíková (Eds.), *Proceedings of the 30th Conference of the International Group for the Psychology of Mathematics Education* (Vol. 4, pp. 465-472). Prague, Czech Republic: PME.
- Bednarz, N., Kieran, C., & Lee, L. (1996). Introduction. In N. Bednarz, C. Kieran, & L. Lee (Eds.), *Approaches to algebra: Perspectives for research and teaching* (pp. 3-12). Dordrecht, The Netherlands: Kluwer.
- Bishop, A. J. (1988). Mathematics education in its cultural context. *Educational Studies in Mathematics*, 19, 179-191.
- Bishop, J. W., & Stump, S. L. (2000). Preparing to teach in the new millennium: Algebra through the eyes of pre-service elementary and middle school teachers. In M. Fernandez (Ed.), *Proceedings of the 22nd Annual Meeting of the North American Chapter of the International Group for the Psychology of Mathematics Education* (pp. 107-113). Columbus, OH: ERIC Clearinghouse for Science, Mathematics, and Environmental Education.



- Bjerg, M., Christensen, L., Hartz, V., Helsing, S., Korsgaard, J., Kragh, L., . . . Rosborg, J. (2000). *Matematik til tiden*. [Mathematics for the present]. Samsø, Denmark: Forlaget Matematik.
- Blanton, M., & Kaput, J. J. (2004). Elementary grades students' capacity for functional thinking. In M. J. Høines & A. B. Fuglestad (Eds.), *Proceedings of the 28th Conference of the International Group for the Psychology of Mathematics Education* (Vol. 2, pp. 135-142). Bergen, Norway: PME.
- Blanton, M., & Kaput, J. J. (2005). Characterizing a classroom practice that promotes algebraic reasoning. *Journal for Research in Mathematics Education*, 36, 412-446.
- Bloedy-Vinner, H. (2001). Beyond unknowns and variables: Parameters and dummy variables in high school algebra. In R. Sutherland, T. Rojano, A. Bell, & R. Lins (Eds.), *Perspectives on school algebra* (pp. 177-190). Dordrecht, The Netherlands: Kluwer.
- Bosch, M., Chevallard, Y., & Gascón, J. (2005). Science or magic? The use of models and theories in didactics of mathematics. In M. Bosch (Ed.), *Proceedings of the Fourth Congress of the European Society for Research in Mathematics Education* (pp. 1254-1263). Barcelona, Spain: Universitat Ramon Llull Editions.
- Bourbaki, N. (1968). *Elements of mathematics: Theory of sets* (A translation of *Éléments de mathématique: Théorie des ensembles*). Reading, MA: Addison-Wesley. (Original work published 1939)
- Brousseau, G. (1997). *The theory of didactical situations in mathematics: Didactique des mathématiques, 1970-1990* (N. Balacheff, M. Cooper, R. Sutherland, & V. Warfield, Eds. & Trans.). Dordrecht, The Netherlands: Kluwer.
- Brousseau, G. (1999). Research in mathematics education: Observation and . . . mathematics. In I. Schwank (Ed.), *Proceedings of the First Conference of the European Society for Research in Mathematics Education* (Vol. 1, pp. 35-48). Osnabrück, Germany: Forschungsinstitut für Mathematikdidaktik.
- Brousseau, G. (2000). Education et didactique des mathématiques. *Educacion Matematica*, 12(1), 5-39. Retrieved from [http://hal.archives-ouvertes.fr/docs/00/46/62/60/PDF/Mexico\\_2000\\_HAL.pdf](http://hal.archives-ouvertes.fr/docs/00/46/62/60/PDF/Mexico_2000_HAL.pdf)

- Brousseau, G. (2006). Mathematics, didactical engineering, and observation. In J. Novotná, H. Moraová, M. Krátká, & N. Stehlíková (Eds.), *Proceedings of the 30th Conference of the International Group for the Psychology of Mathematics Education* (Vol. 1, pp. 3-18). Prague, Czech Republic: PME.
- Brousseau, G., Brousseau, N., & Warfield, V. (2004). Rationals and decimals as required in the school curriculum. Part 1: Rationals as measurement. *Journal of Mathematical Behavior*, 23, 1-20.
- Brousseau, G., & Gibel, P. (2005). Didactical handling of students' reasoning processes in problem solving situations. In C. Laborde, M.-J. Perrin-Glorian, & A. Sierpinska (Eds.), *Beyond the apparent banality of the mathematics classroom* (pp. 13-58). Dordrecht, The Netherlands: Springer.
- Brown, A. L. (1992). Design experiments: Theoretical and methodological challenges in creating complex interventions in classroom settings. *The Journal of the Learning Sciences*, 2(2), 141-178.
- Bruner, J. S. (1964). The course of cognitive growth. *American Psychologist*, 19, 1-15.
- Bruner, J. S. (1985). Vygotsky: A historical and conceptual perspective. In J. V. Wertsch (Ed.), *Culture, communication and cognition: Vygotskian perspectives* (pp. 21-34). Cambridge, UK: Cambridge University Press.
- Bryman, A. (2001). *Social research methods*. Oxford, UK: Oxford University Press.
- Burrell, G., & Morgan, G. (1979). *Sociological paradigms and organisational analysis: Elements of the sociology of corporate life*. London, UK: Heinemann.
- Carr, W., & Kemmis, S. (1986). *Becoming critical: Education, knowledge and action research*. London, UK: RoutledgeFalmer.
- Carraher, D. W., & Schliemann, A. (2002). Modeling reasoning. In K. Gravemeijer, R. Lehrer, B. van Oers, & L. Verschaffel (Eds.), *Symbolizing, modeling and tool use in mathematics education* (pp. 295-304). Dordrecht, The Netherlands: Kluwer.
- Carraher, D. W., Martinez, M. V., & Schliemann, A. (2008). Early algebra and mathematical generalization. *ZDM – The International Journal on Mathematics Education*, 40, 3-22.

- Chazan, D. (1993). High school geometry students' justification for their views of empirical evidence and mathematical proof. *Educational Studies in Mathematics*, 24, 359-387.
- Chevallard, Y. (1990). On mathematics education and culture: Critical afterthoughts. *Educational Studies in Mathematics*, 21, 3-27.
- Chevallard, Y. (1992). Fundamental concepts in didactics: Perspectives provided by an anthropological approach. In R. Douady & A. Mercier (Eds.), *Research in didactique of mathematics: Selected Papers* [Extra issue of *Recherches en Didactique des Mathématiques*] (pp. 131-167). Grenoble, France: La Pensée Sauvage.
- Chevallard, Y. (1999). Didactique? ~~Is it a plaisanterie?~~ You must be joking! A critical comment on terminology. *Instructional Science*, 27, 5-7.
- Cockcroft, W. H. (1982). *Mathematics counts*. London, UK: Her Majesty's Stationery Office.
- Cohen, L., Manion, L., & Morrison, K. (2007). *Research methods in education* (6th ed.). London, UK: Routledge.
- Cole, M., Engeström, Y., & Vasquez, O. A. (1997). Introduction. In M. Cole, Y. Engeström, & O. A. Vasquez (Eds.), *Mind, culture, and activity: Seminal papers from the Laboratory of comparative human cognition* (pp. 1-21). Cambridge, UK: Cambridge University Press.
- Daniels, H. (1996). Introduction: Psychology in a social world. In H. Daniels (Ed.), *An introduction to Vygotsky* (pp. 1-27). London, UK: Routledge.
- Daniels, H. (2001). *Vygotsky and pedagogy*. London, UK: Routledge Falmer.
- Daniels, H. (2007). Pedagogy. In H. Daniels, M. Cole, & J. V. Wertsch (Eds.), *The Cambridge companion to Vygotsky* (pp. 307-331). Cambridge, UK: Cambridge University Press.
- Davydov, V. V. (1962). An experiment in introducing elements of algebra in elementary school. *Soviet Education*, 5, 27-37.
- Davydov, V. V. (1988). The concept of theoretical generalization. *Studies in Soviet Thought*, 36, 169-202.

- Davydov, V. V. (1990). *Types of generalization in instruction: Logical and psychological problems in the structuring of school curricula. Soviet studies in mathematics education* (Vol. 2). Reston, VA: National Council of Teachers of Mathematics. (Original work published 1972)
- Denzin, N. K. (1978). *The research act: A theoretical introduction to sociological methods* (2nd ed.). New York, NY: McGraw-Hill Book Company.
- Denzin, N. K., & Lincoln, Y. S. (2005). Introduction. In N. K. Denzin & Y. S. Lincoln (Eds.), *Handbook of qualitative research* (3rd ed.) (pp. 1-32). Thousand Oaks, CA: Sage.
- Department for Education and Employment. (1999). *The National Curriculum for England: Mathematics, Key stages 1 – 4*. London, UK: Qualifications and Curriculum Authority.
- Dettori, G., Garuti, R., & Lemut, E. (2001). From arithmetic to algebraic thinking using a spreadsheet. In R. Sutherland, T. Rojano, A. Bell, & R. Lins (Eds.), *Perspectives on school algebra* (pp. 191-207). Dordrecht, The Netherlands: Kluwer.
- Devlin, K. (1994). *Mathematics: The science of patterns*. New York, NY: Scientific American Library.
- Dey, I. (2004). Grounded theory. In C. Seale, G. Gobo, J. B. Gubrium, & D. Silverman (Eds.), *Qualitative research practice* (pp. 80-93). London, UK: Sage.
- Diénès, Z. P. (1963). *An experimental study of mathematics-learning*. London, UK: Hutchinson International.
- Directorate for Education and Training. (2006). *Læreplanverket for kunnskapsløftet* [The national curriculum for knowledge promotion in primary and secondary education and training]. Oslo, Norway: Author.
- Doerr, H. M. (2004). Teachers' knowledge and the teaching of algebra. In K. Stacey, H. Chick, & M. Kendal (Eds.), *The future of the teaching and learning of algebra: The 12th ICMI Study* (pp. 267-290). Dordrecht, The Netherlands: Kluwer.
- Dörfler, W. (1991). Forms and means of generalization in mathematics. In A. J. Bishop, S. Mellin-Olsen, & J. van Dormolen (Eds.),

*Mathematical knowledge: Its growth through teaching* (pp. 63-85). Dordrecht, The Netherlands: Kluwer.

Dörfler, W. (2008). En route from patterns to algebra: Comments and reflections. *ZDM – The International Journal on Mathematics Education*, 40, 143-160.

Doxiadis, A. (2003). *Embedding mathematics in the soul: Narrative as a force in mathematics education*. Opening address to the Third Mediterranean Conference of Mathematics Education, Athens, 2003. Retrieved from <http://www.apostolosdoxiadis.com/en/files/essays/embeddingmath.pdf>

Dubinsky, E., & Lewin, P. (1986). Reflective abstraction and mathematics education: The genetic decomposition of induction and compactness. *Journal of Mathematical Behavior*, 5, 55-92.

Duval, R. (2006). A cognitive analysis of problems of comprehension in a learning of mathematics. *Educational Studies in Mathematics*, 61, 103-131.

English, L. D., & Warren, E. (1998). Introducing the variable through pattern exploration. *The Mathematics Teacher*, 9, 166-171.

Firestone, W. A. (1993). Alternative arguments for generalizing from data as applied to qualitative research. *Educational Researcher*, 22(4), 16-23.

Flinders, D. J. (1992). In search of ethical guidance: Constructing a basis for dialogue. *International Journal of Qualitative Studies in Education*, 5(2), 101-116.

Freudenthal, H. (1991). *Revisiting mathematics education: China lectures*. Dordrecht, The Netherlands: Kluwer.

Gascón, J. (2003). From the cognitive program to the epistemological program in didactics of mathematics. Two incommensurable scientific research programs? *For the Learning of Mathematics*, 23(2), 44-55.

Geertz, C. (1973). Thick description: Toward an interpretive theory of culture. In C. Geertz (Ed.), *The interpretation of cultures* (pp. 3-30). New York, NY: Basic Books.

Glaser, B. G. (1978). *Theoretical sensitivity: Advances in the methodology of grounded theory*. Mill Valley, CA: Sociology Press.

- Goodchild, S., Jaworski, B., & Måsøval, H. S. (2007). Workshop on classroom research: Analysis of transcript data. In C. Bergsten, B. Grevholm, H. S. Måsøval, & F. Rønning (Eds.), *Relating practice and research in mathematics education: Proceedings of NORMA 05, Fourth Nordic Conference on Mathematics Education* (pp. 133-147). Trondheim, Norway: Tapir Academic Press.
- Gowers, T. (2008). General goals of mathematical research. In T. Gowers (Ed.), *The Princeton companion to mathematics* (pp. 48-76). Princeton, NJ: Princeton University Press.
- Guba, E. (1981). Criteria for assessing the trustworthiness of naturalistic inquiries. *Educational Communication and Technology Journal*, 29, 75-92.
- Hardy, G. H. (1992). *A mathematician's apology*. Cambridge, UK: Cambridge University Press. (Original work published 1940)
- Hart, K. M. (1981). Ratio and proportion. In K. M. Hart (Ed.), *Children's understanding of mathematics: 11-16* (pp. 88-101). London, UK: John Murray.
- Healy, L., & Hoyles, C. (2000). A study of proof conceptions in algebra. *Journal for Research in Mathematics Education*, 31, 396-428.
- Herbst, P., & Kilpatrick, J. (1999). Pour lire Brousseau. *For the Learning of Mathematics*, 19(1), 3-10.
- Hersant, M., & Perrin-Glorian, M.-J. (2005). Characterization of an ordinary teaching practice with the help of the theory of didactical situations. In C. Laborde, M.-J. Perrin-Glorian, & A. Sierpiska (Eds.), *Beyond the apparent banality of the mathematics classroom* (pp. 113-151). Dordrecht, The Netherlands: Springer.
- Herscovics, N., & Linchevski, L. (1994). A cognitive gap between arithmetic and algebra. *Educational Studies in Mathematics*, 27, 59-78.
- Hewitt, D. (1994). Train spotters' paradise. In M. Selinger (Ed.), *Mathematics teaching* (pp. 47-51). London, UK: Routledge.
- Hitchcock, G., & Hughes, D. (1995). *Research and the teacher: A qualitative introduction to school-based research* (2nd ed.). London, UK: Routledge.

- Hoyles, C. (1997). The curricular shaping of students' approaches to proof. *For the Learning of Mathematics*, 17(1), 7-16.
- Hoyles, C., Noss, R., & Pozzi, S. (2001). Proportional reasoning in nursing practice. *Journal for Research in Mathematics Education*, 32, 4-27.
- Husén, T. (1988). Research paradigms in education. In J. P. Keeves (Ed.), *Educational research, methodology, and measurement: An international handbook* (pp. 17-20). Oxford, UK: Pergamon Press.
- James, G., & James, R. C. (1992). *Mathematics dictionary* (5th ed.). New York, NY: Chapman & Hall.
- Kalman, D. (1997). *Elementary mathematical models: Order aplenty and a glimpse of chaos*. Washington, DC: Mathematical Association of America.
- Kaput, J. J. (1995). A research base supporting long term algebra reform? In D. T. Owens, M. K. Reed, & G. M. Millsaps (Eds.), *Proceedings of the 17th Annual Meeting of the North American Chapter of the International Group for the Psychology of Mathematics Education* (Vol. 1, pp. 71-94). Columbus, OH: ERIC Clearinghouse for Science, Mathematics, and Environmental Education.
- Kaput, J. J. (1998). Transforming algebra from an engine of inequity to an engine of mathematical power by “algebrafying” the K-12 curriculum. In S. Fennel (Ed.), *The nature and role of algebra in the K-14 curriculum: Proceedings of a national symposium* (pp. 25-26). Washington, DC: National Research Council, National Academy Press.
- Kaput, J. J. (1999). Teaching and learning a new algebra. In E. Fennema & T. Romberg (Eds.), *Mathematics classrooms that promote understanding* (pp. 133-155). Mahwah, NJ: Lawrence Erlbaum.
- Kaput, J. J., & Blanton, M. (2001a). Algebrafying the elementary mathematics experience. Part I: Transforming task structures. In H. Chick, K. Stacey, J. Vincent, & J. Vincent (Eds.), *The future of the teaching and learning of algebra. Proceedings of the 12th ICMI Study Conference* (Vol. 1, pp. 344-351). Melbourne, Australia: The University of Melbourne.

- Kaput, J. J., & Blanton, M. (2001b). Student achievement in algebraic thinking: A comparison of 3rd graders' performance on a state 4th grade assessment. In R. Speiser, C. Maher, & C. Walter (Eds.), *Proceedings of the 23rd Annual Meeting of the North American Chapter of the International Group for the Psychology of Mathematics Education* (Vol. 1, pp. 99-107). Columbus, OH: ERIC Clearinghouse for Science, Mathematics, and Environmental Education.
- Kaput, J. J., & Blanton, M. (2003). Developing elementary teachers' "algebra eyes and ears". *Teaching Children Mathematics*, 10, 70-77.
- Karplus, R., Pulos, S., & Stage, E. K. (1983). Early adolescents' proportional reasoning on "rate" problems. *Educational Studies in Mathematics*, 14, 219-233.
- Karpov, Y. V. (2003). Vygotsky's doctrine of scientific concepts. In A. Kozulin, B. Gindis, V. S. Ageyev, & S. M. Miller (Eds.), *Vygotsky's educational theory in cultural context* (pp. 65-82). Cambridge, UK: Cambridge University Press.
- Karpov, Y. V. (2006). Neo-Vygotskian activity theory: Merging Vygotsky's and Piaget's theories of cognitive development. In M. A. Vanchevsky (Ed.), *Frontiers in cognitive psychology* (pp. 31-51). New York, NY: Nova Science.
- Kieran, C. (1989). A perspective on algebraic thinking. In G. Vergnaud, J. Rogalski, & M. Artigue (Eds.), *Proceedings of the 13th Conference of the International Group for the Psychology of Mathematics Education* (Vol. 2, pp. 163-171). Paris, France: PME.
- Kieran, C. (1992). The learning and teaching of school algebra. In D. Grouws (Ed.), *Handbook of research on teaching and learning* (pp. 390-419). New York, NY: Macmillan.
- Kieran, C. (1996). The changing face of school algebra. In C. Alsina, J. Alvarez, B. Hodgson, C. Laborde, & A. Pérez (Eds.), *8th International Congress on Mathematical Education: Selected lectures* (pp. 271-290). Seville, Spain: S.A.E.M. Thales.
- Kieran, C. (1998). Complexity and insight. [Review of the book *The theory of didactical situations in mathematics*, by G. Brousseau]. *Journal for Research in Mathematics Education*, 29, 595-601.



- Kieran, C. (2004). The core of algebra: Reflections on its main activities. In K. Stacey, H. Chick, & M. Kendal (Eds.), *The future of the teaching and learning of algebra: The 12th ICMI Study* (pp. 21-33). Dordrecht, The Netherlands: Kluwer.
- Kirshner, D. (2001). The structural algebra option revisited. In R. Sutherland, T. Rojano, A. Bell, & R. Lins (Eds.), *Perspectives on school algebra* (pp. 83-98). Dordrecht, The Netherlands: Kluwer.
- Kozulin, A. (2003). Psychological tools and mediated learning. In A. Kozulin, B. Gindis, V. S. Ageyev, & S. M. Miller (Eds.), *Vygotsky's educational theory in cultural context* (pp. 15-38). Cambridge, UK: Cambridge University Press.
- Küchemann, D. (1981). Algebra. In K. M. Hart (Ed.), *Children's understanding of mathematics: 11-16* (pp. 102-119). London, UK: John Murray.
- Laborde, C., & Perrin-Glorian, M.-J. (2005). Introduction. In C. Laborde, M.-J. Perrin-Glorian, & A. Sierpiska (Eds.), *Beyond the apparent banality of the mathematics classroom* (pp. 1-12). Dordrecht, The Netherlands: Springer.
- Laborde, C., Perrin-Glorian, M.-J., & Sierpiska, A. (Eds.). (2005). *Beyond the apparent banality of the mathematics classroom*. Dordrecht, The Netherlands: Springer.
- Lakatos, I. (1976). *Proofs and refutations*. Cambridge, UK: Cambridge University Press.
- Lannin, J. K. (2005). Generalization and justification: The challenge of introducing algebraic reasoning through patterning activities. *Mathematical Thinking and Learning*, 7, 231-258.
- Lannin, J. K., Barker, D. D., & Townsend, B. E. (2006). Recursive and explicit reasoning: How can we build student algebraic understanding? *Journal of Mathematical Behavior*, 25, 299-317.
- Lave, J. (1996). The practice of learning. In S. Chaiklin & J. Lave (Eds.), *Understanding practice: Perspectives on activity and context* (pp. 3-32). Cambridge, UK: Cambridge University Press.
- Lave, J., & Wenger, E. (1991). *Situated learning: Legitimate peripheral participation*. Cambridge, UK: Cambridge University Press.

- Lee, L. (1996). An initiation into algebraic culture through generalisation activities. In N. Bednarz, C. Kieran, & L. Lee (Eds.), *Approaches to algebra: Perspectives for research and teaching* (pp. 87-106). Dordrecht, The Netherlands: Kluwer.
- Leontèv, A. N. (1981). The problem of activity in psychology. In J. V. Wertsch (Ed.), *The concept of activity in Soviet psychology* (pp. 37-71). Armonk, NY: M. E. Sharpe.
- Lerman, S. (1996). Intersubjectivity in mathematics learning: A challenge to the radical constructivist paradigm? *Journal for Research in Mathematics Education*, 27, 133-150.
- Linchevski, L., & Herscovics, N. (1996). Crossing the cognitive gap between arithmetic and algebra: Operating on the unknown in the context of equations. *Educational Studies in Mathematics*, 30, 39-65.
- Lincoln, Y. S., & Guba, E. G. (1985). *Naturalistic inquiry*. Newbury Park, CA: Sage.
- Lins, R. (2001). The production of meaning for algebra: A perspective based on the theoretical model of semantic fields. In R. Sutherland, T. Rojano, A. Bell, & R. Lins (Eds.), *Perspectives on school algebra* (pp. 37-60). Dordrecht, The Netherlands: Kluwer.
- Lins, R., & Kaput, J. J. (2004). The early development of algebraic reasoning: The current state of the field. In K. Stacey, H. Chick, & M. Kendal (Eds.), *The future of the teaching and learning of algebra: The 12th ICMI Study* (pp. 47-70). Dordrecht, The Netherlands: Kluwer.
- Lins, R., Rojano, T., Bell, A., & Sutherland, R. (2001). Introduction. In R. Sutherland, T. Rojano, A. Bell, & R. Lins (Eds.), *Perspectives on school algebra* (pp. 1-11). Dordrecht, The Netherlands: Kluwer.
- MacGregor, M., & Stacey, K. (1992). A comparison of pattern-based and equation-solving approaches to algebra. In B. Southwell, B. Perry, & K. Owens (Eds.), *Space – The first and final frontier: Proceedings of the 15th Annual Conference of the Mathematics Education Research Group of Australasia* (pp. 362-371). Sydney, Australia: MERGA.
- MacGregor, M., & Stacey, K. (1993). Seeing a pattern and writing a rule. In J. Hirayabashi, N. Nohda, K. Shigematsu, & F.-L. Lin (Eds.), *Proceedings of the 17th Conference of the International Group for*

*the Psychology of Mathematics Education* (Vol. 1, pp. 181-188). Tsukuba, Japan: PME.

MacGregor, M., & Stacey, K. (1995). The effect of different approaches to algebra on students' perceptions of functional relationships. *Mathematics Education Research Journal*, 7(1), 69-85.

Margolinas, C., Coulange, L., & Bessot, A. (2005). What can the teacher learn in the classroom? In C. Laborde, M.-J. Perrin-Glorian, & A. Sierpinska (Eds.), *Beyond the apparent banality of the mathematics classroom* (pp. 205-234). Dordrecht, The Netherlands: Springer.

Martin, W. G., & Harel, G. (1989). Proof frames of preservice elementary teachers. *Journal for Research in Mathematics Education*, 20, 41-51.

Mason, J. (1989). Mathematical abstraction seen as a delicate shift of attention. *For the Learning of Mathematics*, 9(2), 2-8.

Mason, J. (1996). Expressing generality and roots of algebra. In N. Bednarz, C. Kieran, & L. Lee (Eds.), *Approaches to algebra: Perspectives for research and teaching* (pp. 65-86). Dordrecht, The Netherlands: Kluwer.

Mason, J., & Davis, J. (1991). *Fostering and sustaining mathematics thinking through problem solving*. Geelong, Australia: Deakin University Press.

Mason, J., Graham, A., Pimm, D., & Gowar, N. (1985). *Routes to / Roots of algebra*. Milton Keynes, UK: The Open University Press.

Mason, J., & Pimm, D. (1984). Generic examples: Seeing the general in the particular. *Educational Studies in Mathematics*, 15, 277-289.

Maxwell, J. A. (1992). Understanding and validity in qualitative research. *Harvard Educational Review*, 62, 279-300.

Merriam, S. B. (2009). *Qualitative research: A guide to design and implementation* (3rd ed.). San Francisco, CA: Jossey-Bass.

Miles, M. B., & Huberman, A. M. (1994). *Qualitative data analysis: An expanded sourcebook* (2nd ed.). Thousand Oaks, CA: Sage.

Minick, N. (1987). Introduction. In R. W. Rieber & A. S. Carton (Eds.), *The collected works of L. S. Vygotsky: Vol. 1. Problems of general psychology* (pp. 17-36). New York, NY: Plenum Press.

- Ministry of Education and Church Affairs. (1987). *Mønsterplan for grunnskolen: M87* [Curriculum guidelines for compulsory education: M87]. Oslo, Norway: Author.
- Ministry of Education and Research. (2003). *Rammeplan og forskrift til rammeplan for allmennlærerutdanningen. Fastsatt 3. april 2003 av Utdannings- og forskningsdepartementet* [Framework and regulations for general teacher education for primary and lower secondary education. Established by the Ministry of Education and Research 3 April, 2003]. Oslo, Norway: Author.
- Ministry of Education, Research, and Church Affairs. (1993). *Læreplanverket for videregående opplæring: R94* [National curriculum for upper secondary education and training: R94]. Oslo, Norway: Author.
- Ministry of Education, Research, and Church Affairs. (1996). *Læreplanverket for den 10-årige grunnskolen: L97* [Curriculum for the 10-year compulsory school in Norway: L97]. Oslo, Norway: Nasjonalt læremiddelsenter.
- Molière, J. B. (1732). *Le bourgeois gentilhomme. Comédie-Ballet* [The cit turn'd gentleman. A comedy with interludes]. London, UK: Printed for John Watts at the Printing-Office in Wild-Court near Lincoln's-Inn Fields. (Original work published 1670)
- Moss, J., & Beatty, R. (2006). Knowledge building in mathematics: Supporting collaborative learning in pattern problems. *Computer-Supported Collaborative Learning, 1*, 441-465.
- Måsøval, H. S. (2005). When negotiation of mathematical meaning is replaced by striving for fulfilment of the didactical contract. In C. Winsløw (Ed.), *Didactics of mathematics: The French way* (pp. 21-34). Copenhagen, Denmark: Center for Naturfagenes Didaktik, Københavns Universitet.
- Måsøval, H. S. (2005). Student reasoning constrained by the didactical contract. *Nordic Studies in Mathematics Education, 10*(3-4), 83-99.
- Måsøval, H. S. (2007). Efficiency or rigor? When students see the target as 'doing' more than 'knowing' mathematics. In C. Bergsten, B. Grevholm, H. S. Måsøval, & F. Rønning (Eds.), *Relating practice and research in mathematics education: Proceedings of NORMA 05, Fourth Nordic Conference on Mathematics Education* (pp. 402-415). Trondheim, Norway: Tapir Academic Press.

- Måsøval, H. S. (2009). Complexity of operating beyond naive empiricism when proving a conjectured formula for the general term of a geometrical pattern. In C. Winsløw (Ed.), *Nordic Research in Mathematics Education. Proceedings from NORMA 08* (pp. 25-33). Rotterdam, The Netherlands: Sense.
- National Council of Teachers of Mathematics. (2000). *Principles and standards for school mathematics*. Reston, VA: Author.
- [Nilssen, V. L. \(2007\). Seeing the kids, seeing the student teachers, dealing with two arenas the whole way: A case study of a cooperating teacher mentoring first-year student teachers' mathematics teaching. \(Unpublished doctoral dissertation\). Norwegian University of Science and Technology, Trondheim, Norway.](#)
- Noss, R., Healy, L., & Hoyles, C. (1997). The construction of mathematical meanings: Connecting the visual with the symbolic. *Educational Studies in Mathematics*, 33, 203-233.
- Ontario Ministry of Education and Training. (2005). *The Ontario curriculum, Grades 1 – 8: Mathematics* (Rev. ed.). Retrieved from <http://www.edu.gov.on.ca/eng/curriculum/elementary/math18curr.pdf>
- Orton, A., & Orton, J. (1996). Making sense of children's patterning. In L. Puig & A. Gutiérrez (Eds.), *Proceedings of the 20th Conference of the International Group for the Psychology of Mathematics Education* (Vol. 4, pp. 83-90). València, Spain: PME.
- Orton, A., & Orton, J. (1999). Pattern and the approach to algebra. In A. Orton (Ed.), *Pattern in the teaching and learning of mathematics* (pp. 104-120). London, UK: Cassel Wellington House.
- Orton, A., Orton, J., & Roper, T. (1999). Pictorial and practical contexts and the perception of pattern. In A. Orton (Ed.), *Pattern in the teaching and learning of mathematics* (pp. 121-136). London, UK: Cassel Wellington House.
- Parlett, M., & Hamilton, D. (1976). Evaluation as illumination: A new approach to the study of innovatory programmes (pp. 140-157). In G. Glass (Ed.), *Evaluation Studies Review Annual, 1*. London, UK: Sage.
- Piaget, J. (1970). Piaget's theory. In P. H. Mussen (Ed.), *Carmichael's manual of child psychology* (3rd ed.) (Vol. 1, pp. 703-732). New York, NY: Wiley.

- Pring, R. (2000). *The philosophy of educational research*. London, UK: Continuum.
- Queensland Studies Authority. (2004). *Mathematics Years 1 – 10 syllabus*. Retrieved from [http://www.qsa.qld.edu.au/downloads/early\\_middle/kla\\_maths\\_syll.pdf](http://www.qsa.qld.edu.au/downloads/early_middle/kla_maths_syll.pdf)
- Radford, L. (1996). Some reflections on teaching algebra through generalization. In N. Bednarz, C. Kieran, & L. Lee (Eds.), *Approaches to algebra: Perspectives for research and teaching* (pp. 107-111). Dordrecht, The Netherlands: Kluwer.
- Radford, L. (2000). Signs and meanings in students' emergent algebraic thinking: A semiotic analysis. *Educational Studies in Mathematics*, 42, 237-268.
- Radford, L. (2002a). On heroes and the collapse of narratives: A contribution to the study of symbolic thinking. In A. D. Cockburn & E. Nardi (Eds.), *Proceedings of the 26th Conference of the International Group for the Psychology of Mathematics Education* (Vol. 4, pp. 81-88). Norwich, UK: PME.
- Radford, L. (2002b). The seen, the spoken and the written: A semiotic approach to the problem of objectification of mathematical knowledge. *For the Learning of Mathematics*, 22(2), 14-23.
- Radford, L. (2006). Algebraic thinking and the generalization of patterns: A semiotic perspective. In S. Alatorre, J. L. Cortina, M. Sáiz, & A. Méndez (Eds.), *Proceedings of the 28th Annual Meeting of the North American Chapter of the International Group for the Psychology of Mathematics Education* (Vol. 1, pp. 2-21). Mérida, México: Universidad Pedagógica Nacional.
- Redden, T. (1996). "Wouldn't it be good if we had a symbol to stand for any number?": The relationship between natural language and symbolic notation in pattern description. In L. Puig & A. Gutiérrez (Eds.), *Proceedings of the 20th Conference of the International Group for the Psychology of Mathematics Education* (Vol. 4, pp. 195-202). València, Spain: PME.
- Resnik, M. D. (1981). Mathematics as a science of patterns: Ontology and reference. *Noûs*, 15, 529-550.
- Salomon, G. (1993). No distribution without individuals' cognition: A dynamic interactional view. In G. Salomon (Ed.), *Distributed cogni-*

tions: *Psychological and educational considerations* (pp. 111-138). Cambridge, UK: Cambridge University Press.

- Seeger, F. (1989). *Davydov's theory of generalization: Theoretical thinking and representation in learning and teaching algebra* (Occasional paper 117). Bielefeld, Germany: Institut für Didaktik der Mathematik der Universität Bielefeld.
- Sensevy, G., Schubauer-Leoni, M.-L., Mercier, A., Ligozat, F., & Perrot, G. (2005). An attempt to model the teacher's actions in the mathematics class. In C. Laborde, M.-J. Perrin-Glorian, & A. Sierpiska (Eds.), *Beyond the apparent banality of the mathematics classroom* (pp. 153-181). Dordrecht, The Netherlands: Springer.
- Servais, W., & Varga, T. (1971). *Teaching school mathematics: A UNESCO source book*. Middlesex, UK: Penguin Books.
- Sfard, A. (1991). On the dual nature of mathematical conceptions: Reflections on processes and objects as different sides of the same coin. *Educational Studies in Mathematics*, 22, 1-36.
- Sfard, A. (1992). Operational origins of mathematical notions and the quandary of reification: The case of function. In G. Harel & E. Dubinsky (Eds.), *The concept of function: Aspects of epistemology and pedagogy* (MAA Notes, Vol. 25, pp. 59-84). Washington, DC: Mathematical Association of America.
- Sfard, A. (1995). The development of algebra: Confronting historical and psychological perspectives. *Journal of Mathematical Behavior*, 14, 15-39.
- Sieber, J. E. (1992). *Planning ethically responsible research: A guide for students and internal review boards*. Newbury Park, CA: Sage.
- Sierpiska, A. (1995). Some reflections on the phenomenon of French didactique. *Journal für Mathematik-Didaktik*, 16(3/4), 163-192.
- Sierpiska, A. (1999). *Lectures on the theory of didactic situations* [Lecture notes]. Retrieved from <http://annasierpiska.wkrib.com/pdf/TDSLecture%208.pdf>
- Sierpiska, A. (2005). Preface. In C. Laborde, M.-J. Perrin-Glorian, & A. Sierpiska (Eds.), *Beyond the apparent banality of the mathematics classroom* (pp. v-viii). Dordrecht, The Netherlands: Springer.

- Skemp, R. R. (1976). Relational understanding and instrumental understanding. *Mathematics Teaching*, 77, 20-26.
- Skemp, R. R. (1982). Communicating mathematics: Surface structures and deep structures. *Visible Language*, 16, 281-288.
- Skoogh, L., Pedersen, P. I., & Breiteig, T. (1994). *Regnereisen 9A: Grunnbok*. [The calculating journey 9A: Basic book]. Oslo, Norway: Aschehoug.
- Stacey, K. (1989). Finding and using patterns in linear generalising problems. *Educational Studies in Mathematics*, 20, 147-164.
- Stacey, K., & MacGregor, M. (2001). Curriculum reform and approaches to algebra. In R. Sutherland, T. Rojano, A. Bell, & R. Lins (Eds.), *Perspectives on school algebra* (pp. 141-153). Dordrecht, The Netherlands: Kluwer.
- Stake, R. E. (1995). *The art of case study research*. London, UK: Sage.
- Stake, R. E. (2005). Qualitative case studies. In N. K. Denzin & Y. S. Lincoln (Eds.), *Handbook of qualitative research* (3rd ed.) (pp. 443-466). Thousand Oaks, CA: Sage.
- Stečkin, S. B. (1999). Theory of functions of a real variable. In A. D. Aleksandrov, A. N. Kolmogorov, & M. A. Lavrent'ev (Eds.), *Mathematics: Its content, methods and meaning* (Vol. 3, pp. 3-36). Mineola, NY: Dover Publications. (Original work published 1963)
- Steele, D. (2008). Seventh-grade students' representations for pictorial growth and change problems. *ZDM – The International Journal on Mathematics Education*, 40, 97-110.
- Steffe, L. P., & Gale, J. (Eds.). (1995). *Constructivism in education*. Hillsdale, NJ: Lawrence Erlbaum.
- Steinbring, H. (1997). Epistemological investigation of classroom interaction in elementary mathematics teaching. *Educational Studies in Mathematics*, 32, 49-92.
- Steinbring, H. (1998). Elements of epistemological knowledge for mathematics teachers. *Journal of Mathematics Teacher Education*, 1, 157-189.



- Steinbring, H. (2005). *The construction of new mathematical meaning in classrooms interaction: An epistemological perspective*. Berlin, Germany: Springer.
- Stenhouse, L. (1988). Case study methods. In J. P. Keeves (Ed.), *Educational research, methodology, and measurement: An international handbook* (pp. 49-53). Oxford, UK: Pergamon Press.
- Stoll, R. R. (1979). *Set theory and logic*. Mineola, NY: Dover. (Original work published 1963)
- Tall, D., & Vinner, S. (1981). Concept image and concept definition in mathematics with particular reference to limits and continuity. *Educational Studies in Mathematics*, 12, 151-169.
- The Faculty Board. (2003). *Fagplan for Matematikk 1: Vedtatt av Avdelingsstyret i møte 17. juni, 2003*. [Study plan for Mathematics 1: Established by The Faculty Board 17 June, 2003]. Trondheim, Norway: Sør-Trøndelag University College. Retrieved from <http://www.hist.no/attachment.ap?id=639>
- The National Committee for Research Ethics in the Social Sciences and the Humanities. (2006). *Forskningsetiske retningslinjer for samfunnsvitenskap, humaniora, jus og teologi* [Guidelines for research ethics in the social sciences, the humanities, law, and theology]. Oslo, Norway: Author. Retrieved from <http://www.etikkom.no/Forskningsetikk/Etiske-retningslinjer/Samfunnsvitenskap-jus-og-humaniora/>
- Ursini, S. (2001). General methods: A way of entering the world of algebra. In R. Sutherland, T. Rojano, A. Bell, & R. Lins (Eds.), *Perspectives on school algebra* (pp. 209-230). Dordrecht, The Netherlands: Kluwer.
- Van der Veer, R. (2001). The idea of units of analysis: Vygotsky's contribution. In S. Chaiklin (Ed.), *The theory and practice of cultural-historical psychology* (pp. 93-106). Aarhus, Denmark: Aarhus University Press.
- Vergnaud, G. (1983). Multiplicative structures. In R. Lesh & M. Landau (Eds.), *Acquisition of mathematics concepts and processes* (pp. 127-174). New York, NY: Academic Press.

- von Glasersfeld, E. (1995). A constructivist approach to teaching. In L. P. Steffe & J. Gale (Eds.), *Constructivism in education* (pp. 3-15). Hillsdale, NJ: Lawrence Erlbaum.
- Vygotsky, L. S. (1978). *Mind in society: The development of higher psychological processes* (M. Cole, V. John-Steiner, S. Scribner, & E. Souberman, Eds.). Cambridge, MA: Harvard University Press.
- Vygotsky, L. S. (1981a). The instrumental method in psychology. In J. V. Wertsch (Ed.), *The concept of activity in Soviet psychology* (pp. 134-143). Armonk, NY: M. E. Sharpe.
- Vygotsky, L. S. (1981b). The genesis of higher mental functions. In J. V. Wertsch (Ed.), *The concept of activity in Soviet psychology* (pp. 144-188). Armonk, NY: M. E. Sharpe.
- Vygotsky, L. S. (1987). Thinking and speech (N. Minick, Trans.). In R. W. Rieber & A. S. Carton (Eds.), *The collected works of L. S. Vygotsky: Vol. 1. Problems of general psychology* (pp. 39-285). New York, NY: Plenum Press. (Original work published 1934)
- Vygotsky, L. S. (1997a). Analysis of higher mental functions (M. J. Hall, Trans.). In R. W. Rieber (Ed.), *The collected works of L. S. Vygotsky: Vol. 4. The history of the development of higher mental functions* (pp. 65-82). New York, NY: Plenum Press. (Original work published 1931)
- Vygotsky, L. S. (1997b). Mind, consciousness, the unconscious (R. Van der Veer, Trans.). In R. W. Rieber & J. Wollock (Eds.), *The collected works of L. S. Vygotsky: Vol. 3. Problems of the theory and history of psychology* (pp. 109-121). New York, NY: Plenum Press. (Original work published 1930)
- Warren, E. (2000). Visualisation and the development of early understanding in algebra. In T. Nakahara & M. Koyama (Eds.), *Proceedings of the 24th Conference of the International Group for the Psychology of Mathematics Education* (Vol. 4, pp. 273-280). Hiroshima, Japan: PME.
- Warren, E. (2005). Young children's ability to generalise the pattern rule for growing patterns. In H. L. Chick & J. L. Vincent (Eds.), *Proceedings of the 29th Conference of the International Group for the Psychology of Mathematics Education* (Vol. 4, pp. 305-312). Melbourne, Australia: PME.

- Warren, E., Cooper, T. J., & Lamb, J. T. (2006). Investigating functional thinking in the elementary classroom: Foundations for early algebraic thinking. *Journal of Mathematical Behavior*, 25, 208-223.
- Weisstein, E. W. (Ed.). (2009). *CRC Encyclopedia of mathematics* (3rd ed., Vols. 1-3). Boca Raton, FL: Chapman & Hall/CRC.
- Weldon, M. S. (2000). Remembering as a social process. In D. L. Medin (Ed.), *The psychology of learning and motivation* (pp. 67-120). San Diego, CA: Academic Press.
- Wertsch, J. V. (1984). The zone of proximal development: Some conceptual issues. In B. Rogoff & J. V. Wertsch (Eds.), *Children's learning in the "Zone of proximal development"* (pp. 7-18). San Francisco, CA: Jossey-Bass.
- Wertsch, J. V. (1985). *Vygotsky and the social formation of mind*. Cambridge, MA: Harvard University Press.
- Wertsch, J. V. (1991). *Voices of the mind: A sociocultural approach to mediated action*. Cambridge, MA: Harvard University Press.
- Wertsch, J. V. (1994). The primacy of mediated action in sociocultural studies. *Mind, Culture, and Activity*, 1(4), 202-208.
- Wertsch, J. V. (1998). *Mind as action*. New York, NY: Oxford University Press.
- Wertsch, J. V., del Río, P., & Alvarez, A. (1995). Sociocultural studies: History, action, and mediation. In J. V. Wertsch, P. del Río, & A. Alvarez (Eds.), *Sociocultural studies of mind* (pp. 1-34). Cambridge, UK: Cambridge University Press.
- Whitehead, A. N. (1947). *Essays in science and philosophy*. New York, NY: Philosophical Library.
- Wittgenstein, L. (1978). *Remarks on the foundations of mathematics* (Rev. ed.). Cambridge, MA: Massachusetts Institute of Technology Press. (Original work published 1956)
- Yin, R. K. (2009). *Case study research: Design and methods* (4th ed.). Los Angeles, CA: Sage.
- Zazkis, R., & Liljedahl, P. (2002). Generalization of patterns: The tension between algebraic thinking and algebraic notation. *Educational Studies in Mathematics*, 49, 379-402.



# 11 Appendices<sup>115</sup>

Appendix A: Four mathematical tasks with which the students engaged	302
Appendix B: Brief summary of students' solutions to tasks	305
Appendix C: Disposition for information about PhD-project to potential research participants	312
Appendix D: Consent form	314
Appendix E: Consent form for showing of video recordings	315
Appendix F: Transcription codes	316

---

<sup>115</sup> Appendices are translated into English by the author.

## Appendix A: Four mathematical tasks with which the students engaged

---

### Task 1

Below you see the development of the first two shapes in a pattern.

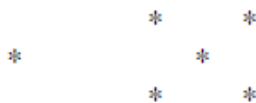

- Draw the third and fourth shapes in this pattern. You may use the squared paper.
- Count the number of stars in each of the shapes you have now, and put the results into a table. Explain how the number of stars increases from one shape to the next. Use this to calculate how many stars there are in the fifth shape.
- What you have found in task b) above is called a recursive (or indirect) formula. Can you express it in terms of mathematical symbols?
- Try to find a connection between the position of a shape and the number of stars in that shape. This is called an explicit formula. Can you express such a formula in terms of mathematical symbols?
- You have got a box with 200 stars that you are going to use to make as big a figure as possible in this pattern. (You are not supposed to start with figure number one and make all successive figures). How big a figure can you make?

### Task 2<sup>116</sup>

- A growing picture made of stars is presented below. Express the number of stars in this pattern as a function of  $n$ .



---

<sup>116</sup> Task 2a is reproduced from *Regnereisen 9A* (Skogh, Pedersen, & Breiteig, 1994, p. 189), a mathematics textbook for Grade 9, written in accordance with the Curriculum Guidelines for Compulsory Education in Norway, M87 (Ministry of Education and Church Affairs, 1987).

- b) Task a) asked for an explicit formula for the pattern. Can you find also a recursive formula?
- c) Can you draw a shape that would precede the ones given above which would be consistent with the given pattern?

### Task 3 (Part I)

Look at the shapes below. You may use centicubes to concretise.

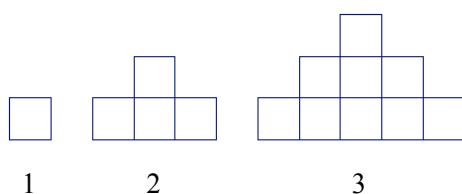

- a) How many cubes will there be in the fourth shape? And in the fifth?
- b) How many do you think there will be in shape number 10? And in shape number  $n$ ?
- c) What kinds of numbers are present in these shapes? In each row, and totally in the shape?
- d) Can you express what the shapes seem to show, as a mathematical statement?
  - In words?
  - In symbols?

### Task 3 (Part II)

The mathematical statement that you have formulated above is only based on a few observations. It is therefore just a conjecture. In order for it to become a justified statement, it needs to be proved. We will now look at a possible way to do this.

Below, the staircase towers have been extended into rectangles.

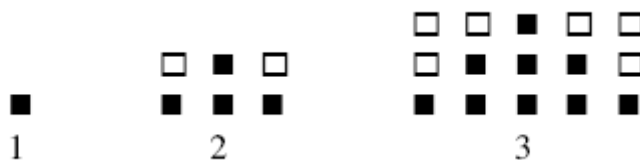

- e) Build or draw (using two colours or symbols) the next shape in this pattern.
- f) Find an explicit formula for the total number of squares in the  $n$ -th shape. Then find an explicit formula for the number of  $\square$  in the  $n$ -th shape.
- g) Use this to find the number of  $\blacksquare$  in shape number  $n$ .
- h) Discuss if the conjecture from earlier in the task can be considered proved now.
- i) An alternative way to prove it may be through a so-called proof by induction (see last page). Those who want to go a bit further here can try that!

#### Task 4



Thorvaldsen's museum in Copenhagen contains several floor mosaics with mathematical content. We looked at one mosaic last Friday, and here we shall look at another one. (The picture is reproduced from the book *Matematik til tiden* by Bjerg et al., 2000).

This pattern can be thought of as built up by equal squared areas containing bright and dark mosaic tiles.

On the shape below the pattern is reproduced schematically with ■ for each of the dark squared tiles and □ for each of the bright ones.

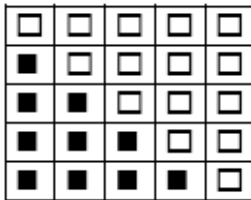

- If this shape were part of a sequence of shapes, what would the next one look like?
- What kinds of figurate numbers do you find in the bright and the dark areas, and in the shape as a whole?
- Express what the shape tells you about these numbers in terms of a mathematical statement.



## Appendix B: Brief summary of students' solutions to the mathematical tasks

---

### Task 1 – Group 1 (Ida & Alice; Sophie is sick)

a) Pattern:



b)

Fig. no.	1	2	3	4	5	6
Numb. of stars	1	5	13	25	41	61
		+4	+8	+12	+16	+20

“The increase of the number of stars increases by four each time”.

c) Recursive formula:  $((n-1) \cdot 4) + (s_{n-1}) = s_n$  (with maieutic practice by teacher T).

d) Explicit formula:

$$\begin{aligned}
 (4 \cdot 0) + 1 & \quad s_1 = 1 \\
 (4 \cdot 1) + 1 & \quad s_1 + 4 = s_2 = 5 = 1 + 4 \\
 (4 \cdot 3) + 1 & \quad s_3 = s_2 + 8 = 1 + 4 + 8 = 13 \\
 (4 \cdot 6) + 1 & \quad s_4 = s_3 + 12 = 1 + 4 + 8 + 12 = 25 \\
 (4 \cdot 10) + 1 & \quad s_5 = s_4 + 16 = 1 + 4 + 8 + 12 + 16 = 41 \\
 (4 \cdot 15) + 1 & \quad s_6 = s_5 + 20 = 1 + 4 + 8 + 12 + 16 + 20 = 61 \\
 (4 \cdot 21) + 1 & \quad s_7 = s_6 + 24 = 1 + 4 + 8 + 12 + 16 + 20 + 24 = 85 \\
 (4 \cdot 28) + 1 & \quad s_8 = s_7 + 28 = 1 + 4 + 8 + 12 + 16 + 20 + 24 + 28 = 113 \\
 (4 \cdot 36) + 1 & \quad s_9 = s_8 + 32 = 1 + 4 + 8 + 12 + 16 + 20 + 24 + 28 + 32 = 145
 \end{aligned}$$

The students do not succeed in generalising the pattern in terms of an explicit formula. Teacher T tries to help them generalise the multiplier of 4 in the products to the left, but claims himself not able to generalise it either. Last part of lesson is used on trying to calculate the number of stars as the difference between the total number of stars when empty places are filled in, and the number of stars filled in. Time runs out.

e) There was no time left to do this task. The students spent the whole time on the previous tasks.

## Task 1 – Group 2 (Paul, Anne & Helen)

a) Pattern alternatives:

Paul and Anne (Pattern 1):



Helen (Pattern 2):



b) Pattern 1:

Paul:

Figur	1	2	3	4	5
	1	5	13	25	41
		$1+1 \cdot 4$	$5+2 \cdot 4$	$13+3 \cdot 4$	$25+4 \cdot 4$

Helen:

1	1	
2	5	+4
3	13	+8
4	25	+12
5	41	+16

“First, it increases by four then by eight and then by twelve”. “By the four times table”.

Pattern 2:

Paul:

Figur	1	2	3	4	5
	1	5	9	13	17

Helen:

Antall stjerner	1	2	3	4	5
	1	5	9	13	17

4                      4                      4                      4

”Plus four each time”.

- c) Recursive formula: They believe they have found the recursive formulae when it is indeed the explicit formulae. When reading the next task (asking for explicit formula), they conclude that they have indeed found the explicit formulae. They do not pay more attention to representing the recursive formulae by mathematical symbols.
- d) Pattern 1:  $a_n = n^2 + (n-1)^2$
- Pattern 2:  $a_n = 1 + (n-1)4$
- e) They solve the quadratic equation  $n^2 - 2n + 1$  on calculator and write:  $n = 10,5 \vee n = \cancel{9,5}$ . Concludes that the largest figure they can build with 200 stars is the 10th figure.

### Task 2 – Group 1 (Ida & Alice; Sophie is sick)

Did not come this far in the task sheet. They spent all time on Tasks 1a-d.

### Task 2 – Group 2 (Paul, Anne & Helen)

- a) Function of  $n$ :  $a_n = (2n+1)^2 - n^2$ .
- b) Recursive formula:  $a_{n+1} = a_n + 6n + 1$ .
- c) One star.

### Task 3 – Group 1 (Sophie, Ida & Alice)

- a) Number of cubes in figure; 4th: 16; 5th: 25.
- b) 10th: Does not pay attention to this. The  $n$ -th:  $n^2$ .
- c) In each row: Odd numbers. Totally in the figure: Square numbers.
- d) Mathematical statement in words: The whole figure becomes a square number.

Mathematical statement in symbols:  $F_n = n^2$ .

Teacher E tries to make them express the total number by focusing on how the figure is built up. Teacher E interprets Alice's answer to mean that she has understood the arithmetical relation between odd numbers and square numbers. He sets them the task of writing with symbols that we add the first  $n$  odd numbers. Teacher E writes in Alice's notebook:

$$1 + 3 = 2^2$$

$$1 + 3 + 5 = 3^2$$

$$1 + 3 + 5 + L + \dots = n^2$$

and asks how he should write the  $n$ -th odd number?

Students do not succeed in symbolising the  $n$ -th odd number, but they try to find an expression for the increase from one figure to the next, and finds that  $n + (n - 1)$  equals the increase from the  $(n - 1)$ -th square number to the  $n$ -th square number. They conjecture the formula:  $n + (n - 1) = n^2$ . They consider it a "two-in-one formula" because the left hand side equals the increase and the right hand side equals how many cubes there are totally. But realises the inconsistency (exemplified by  $5 \neq 9$ ).

They then write the third and fourth row of the table in which the teacher has completed the first two and the  $n$ -th rows:

$$1 + 3 = 2^2$$

$$1 + 3 + 5 = 3^2$$

$$1 + 3 + 5 + 7 = 4^2$$

$$1 + 3 + 5 + 7 + 9 = 5^2$$

$$1 + 3 + 5 + L + \dots = n^2$$

Teacher E enters room. Makes them aware of the fact that  $n + (n - 1)$  symbolises the  $n$ -th odd number and that it can be written  $2n - 1$ . He then writes  $2n - 1$  for the  $n$ -th odd number (place left open in the formula in figure above, last line), so the formula becomes:  $1 + 3 + 5 + L + 2n - 1 = n^2$ . Students have not considered this a formula ("because a formula is in a way *no numbers...*").

e) 4th rectangle built in centicubes:

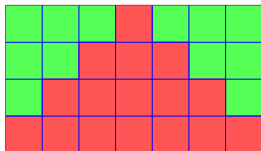

They establish explicit formula for the  $n$ -th rectangle by using that the number of black squares (towers) equals the square numbers (which is, indeed, what they are supposed to prove) and find by guess and check that the number of white squares is given by  $n(n - 1)$ . Results in the formula:  $n^2 + n \cdot (n - 1)$ .

Teacher E tells them this is not sufficient. He tries to mediate what a valid

mathematical proof involves and how to utilise structure. Practices *maieutic* to help them (interaction with Alice) find length and width of rectangle.

Alice writes:

$$(n \cdot (2n - 1)) - (n \cdot (n - 1))$$

$$(2n^2 - n) - (n^2 - n)$$

$$\boxed{= n^2}$$

Alice indicates some understanding of a generic example. Sophie indicates she has not understood what was wrong with their original formula,  $n^2 + n \cdot (n - 1)$ .

They suggest they are not competent to do this voluntary task (laughter).

### Task 3 – Group 2 (Paul, Anne & Helen)

- a) Number of cubes in figure; 4th: 16; 5th: 25.
- b) 10th: 100. The  $n$ -th:  $n^2$ .
- c) In each row: odd numbers. Totally in the element: square numbers.
- d) In each element, the number of cubes is equal to the square of the element's position.

$$a_n = n^2.$$

- e) Picture drawn:

```

○ ○ ○ X ○ ○ ○
○ ○ X X X ○ ○
○ X X X X X ○
X X X X X X X

```

- f) Rectangles:

$$a_1 = 1 \cdot 1 \quad 1$$

$$a_2 = 2 \cdot 3 \quad 1+2$$

$$a_3 = 3 \cdot 5 \quad 1+2+2$$

$$a_4 = 4 \cdot 7 \quad 1+2+2+2$$

$$a_5 = 5 \cdot 9 \quad 1+2+2+2+2$$

Generalised as  $a_n = n(2n - 1)$ .

Number of white cubes by guess and check:  $a_n = n(n - 1)$ .

Total in rectangle  $a_n = n \cdot (2n - 1)$

- g) Formula W  $n(n - 1)$

Black cubes  $n(2n - 1) - n(n - 1) = n^2$

- h) Discussion if they consider the conjecture from earlier proved: Just comment that they will get the black cubes when they take the difference between the total number of cubes and number of white cubes in rectangle. No substantial reflection on the nature of proof or the disparity between formulae established by guess and check and formulae established in basis of structural relationships.
- i) Induction proof:  
 “Sum of first  $n$  odd numbers equals  $n$ -th square number” expressed as a recursive formula:  $a_{n+1} = a_n + 1 + 2n$ .

Teacher intervenes and suggests that they, rather than completing the induction proof, continue on the next task.

### Task 4 – Group 1 (Sophie, Ida & Alice)

Did not come this far in the task sheet (spent whole lesson on Task 3).

### Task 4 – Group 2 (Paul, Anne & Helen)

- a) Alternatives for continuation of pattern. Students agree on working with Alternative 1.

Alternative 1

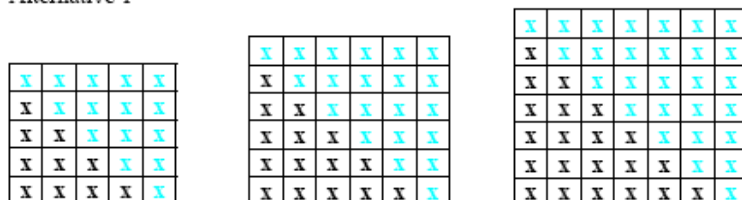

Alternative 2



Alternative 3



- b) The rule for bright tiles and dark tiles is  $1+2+3+4+5+L$  ; number of dark tiles equals number of previous bright tiles (“bright ones are one level above the dark ones”). The figure as a whole is a *square number*.  
 Teacher E reveals that the figurate numbers found in the dark tiles and bright tiles are called *triangular numbers*.

- c) What the figure expresses as a mathematical statement: The fifth square number equals the sum of the fifth and the fourth triangular number (expressed in natural language). No generalisation.

### **Information about the project Investigative approach to mathematical understanding – with focus on the conversation**

A doctoral project with the intention to develop knowledge about student teachers' algebra learning at the university college and learning to teach algebra in the practice field.

#### **Intention of the project – what does it aim to develop knowledge about?**

Student teachers' algebra learning at the university college  
Student teachers' engagement with tasks on algebraic generalisation and proof  
Focus on the collaboration and conversation

Student teachers' learning to teach algebra to pupils in school  
What aims do student teachers define for their teaching (concerning pupils' learning). How do they accomplish teaching? → Interpretation of student teachers' conception of mathematical knowledge and of their beliefs about how this knowledge can be learned.

Aim: Try to get an understanding of what is happening through the eyes of the research participants → **Qualitative approach.**

#### **Research style**

Case study  
Two cases where each case consists of a practice group  
Time commitments: Pilot November/December 2003. Data collection Spring 2004 and autumn 2004.

#### **Requirements to research participants**

Be in the same practice group and have school based practice in the same school for the first two years of the programme  
Be member of a well-functioning practice group  
Have a fair interest in mathematics  
Take part in all mathematics teaching at the university college  
Be willing to let Heidi observe and video record mathematics small-group lessons and some whole-class lessons at the university college; about 10 lessons for each group.

---

<sup>117</sup> This appendix is a translation of a document used by me on October 8, 2003, as disposition for an oral presentation of my intended PhD-project to potential research participants.



Be willing to let Heidi observe and video record student teachers' mathematics teaching in the practice field; about 6 lessons for each group.

Video-meetings with each group where the student teachers can see extracts from video recordings. Transcripts from the chosen episodes will be sent in advance. The student teachers can ask questions about or comment on the video recordings or transcripts, but there is no expectation that they must give any response to the episodes.

*Who has access to the collected data?* (Who can see the video recordings and listen to the audio-recordings?)

The researcher (Heidi)

The researcher's supervisors and examiners

Anonymity in the dissertation and other publications from the project

Use of pseudonyms

The name of the university college will not be used

To those who might be interested in participation:

Discuss it in the practice group. In case of interest, every member of the practice group writes (individually) on a sheet of paper briefly about the following (hand in to Heidi):

- Name
- Age
- Previous education
- Presence in mathematics teaching
- Your judgement of how your practice group is functioning

## Appendix D: Consent form

---

### **Consent**

I agree to collaborate with Heidi S. Måsøval in her PhD-study, “*Investigative approach to mathematical understanding – with focus on the conversation*”. I agree to be observed and video recorded during mathematics lessons at the university college and during mathematics teaching in the practice field. I agree that conversations with me about mathematics teaching and learning are audio recorded.

I am aware that the collected data will be transcribed and analysed, and that parts of it will be used in reporting from the study. The data will be anonymised by the use of pseudonyms in transcribing and reporting from the study.

I am free to withdraw from the project at any time.

---

Signature

## Appendix E: Consent form for showing of video recordings

---

### **Consent to use video recordings**

from Heidi S. Måsøval's PhD-project Expressing and justifying generality in geometric patterns: A case study of first-year student teachers' small-group collaboration at a university college

(Erase from the line below what is not in accordance with your decision)

I **agree** / **do not agree** to let Heidi S. Måsøval show excerpts from video tapes which include me. This involves recordings made in her PhD-project during the period January – December, 2004.

The agreement applies to organised teaching situations or other professional situations, for instance presentations at scientific conferences or seminars.

---

Signature

---

Date

## Appendix F: Transcription codes

---

[Pause <i>n</i> s]	Pause <i>n</i> seconds
<b>N</b>	Omitted turns
Italics	Emphasis (Italicised letter represents a variable)
[Text in brackets]	Account of nonverbal action, or comment on utterance
[indecipherable]	One or more words omitted because not possible to decipher
(A: Interjection)	Interjection by person A during another person's turn

