

Vibration Control of a Base-Isolated Building using Wavelets

Hamid Reza Karimi

*Department of Engineering, Faculty of Engineering and Science, University of Agder,
Serviceboks 509, N-4898 Grimstad, Norway (e-mail: hamid.r.karimi@uia.no)*

Abstract: This paper proposes a numerical approach for finding an optimal control based on wavelet functions for vibration reduction of a base-isolated building subjected to actual earthquakes. The objective is two-fold: (1) to find a computational method using properties of Haar functions, and (2) to calculate controller gains approximately by solving only algebraic equations instead of solving the Riccati differential. Simulation results are included to demonstrate the validity and applicability of the technique.

Keywords: Haar wavelet; vibration control; structural control.

1. INTRODUCTION

Vibration control has emerged as an important area of scientific and technological development in recent years. Developments in vibration control have allowed successful application of the concept in numerous areas. A variety of control techniques, such as LQR control, sliding mode control, backstepping control, H_2 control, H_∞ control, guaranteed-cost control and multi-objective control have been used in vibration systems (see for instance [1]-[5]).

Many papers analyze numerical methods for finding an efficient algorithm to calculate a vibration control using the feedback loop approach which is based on the instantaneous knowledge of the system states. Specifically, in the field of dynamic systems and control, orthogonal functions-based techniques of analysis, identification and control have received considerable attention in the recent years. This is evident from the vast amount of literature published over the last two decades [6]. The various systems of orthogonal functions may be classified into two categories: (1) piecewise constant basis functions such as Haar functions (HFs) [7]-[8], block pulse functions [9] and Walsh functions [10], and (2) orthogonal polynomials such as Legendre, Laguerre, Chebyshev, Jacobi, Hermite along with sine-cosine functions [11]-[12].

It is noting that the main characteristic of the piecewise constant basis functions is that these problems are reduced to those of solving a system of algebraic equations for the solution of problems described by differential equations. Thus, the solution, identification and optimisation procedure are either greatly reduced or much simplified accordingly [13]-[15]. However, the problems considered so far for orthogonal functions-based solutions include response analysis, optimal control, parameter estimation, model reduction, controller design, and state estimation. They have been applied to linear time-invariant and time-varying systems, nonlinear and distributed parameter systems, which include scaled systems, stiff systems, delay systems, singular systems and multivariable systems [16].

In the sequel, we apply the HFs to the finite-time optimal control problem of the base-isolated building. Mathematical model of the structure is presented. Moreover, the properties of HFs, Haar integral operational and Haar product operational matrices are given and are utilized to provide a systematic computational framework to find the optimal trajectory and finite-time optimal control of the vibration system approximately with respect to a quadratic cost function by solving only the linear algebraic equations instead of solving the differential equations. One of the main advantages is solving linear algebraic equations instead of solving nonlinear Riccati equation to optimize the control problem of the vibration system. Numerical results are presented to illustrate the applicability of the technique.

The rest of this paper is organized as follows. Section 2 introduces properties of the HFs. A dynamic model of the vibration structure is provided in Section 3. Algebraic solution of the system is given in Section 4 and development of optimal state trajectories and optimal vibration control by HFs are presented in Section 5. Simulation results of the vibration system are shown in Section 6 and finally the conclusion is discussed.

1.1. Notations.

A : $r \times s$ matrix A with dimension $r \times s$;
 I_r identity matrix with dimension $r \times r$;
 0_r zero matrix with dimension $r \times r$;
 $0_{r \times s}$ zero matrix with dimension $r \times s$;
 \otimes Kronecker product;
 $\text{vec}(X)$ the vector obtained by putting matrix X into one column;
 $\text{tr}(A)$ trace of matrix A .

2. HAAR FUNCTIONS

The oldest and most basic of the wavelet systems is named Haar wavelet, whose functions are given by

$$\begin{aligned} \psi_0(t) &= 1, \quad t \in [0, 1), \\ \psi_1(t) &= \begin{cases} 1, & \text{for } t \in [0, \frac{1}{2}), \\ -1, & \text{for } t \in [\frac{1}{2}, 1), \end{cases} \end{aligned} \quad (1)$$

where $\phi(t) = \psi_0(t)$ and $\psi_i(t) = \psi_1(2^j t - k)$ for $i \geq 1$ with $i = 2^j + k$ for $j \geq 0$ and $0 \leq k < 2^j$. We can easily see that the $\psi_0(t)$ and $\psi_1(t)$ are compactly supported, they give a local description, at different scales j , of the considered function [8]. $\phi(\cdot)$ is sometimes called the ‘father wavelet’ and $\psi(\cdot)$, the ‘mother wavelet’. The finite series representation of any square integrable function $y(t)$ in terms of HF’s in the interval $[0, 1)$, namely $\hat{y}(t)$, is given by

$$\hat{y}(t) = \sum_{i=0}^{m-1} a_i \psi_i(t) := a^T \Psi_m(t) \quad (2)$$

where $a := [a_0 \ a_1 \ \dots \ a_{m-1}]^T$ and $\Psi_m(t) := [\psi_0(t) \ \psi_1(t) \ \dots \ \psi_{m-1}(t)]^T$ for $m = 2^j$ and the Haar coefficients a_i are given by

$$a_i = 2^{\frac{j}{2}} \int_0^1 y(t) \psi_i(t) dt. \quad (3)$$

The integration of the vector $\Psi_m(t)$ can be approximated by

$$\int_0^t \Psi_m(r) dr = P_m \Psi_m(t) \quad (4)$$

where the matrix P_m represents the integral operator matrix for piecewise constant basis functions on the interval $[0, 1)$ at the resolution m . For HF’s, the square matrix P_m satisfies the following recursive formula [17]:

$$P_m = \frac{1}{2m} \begin{bmatrix} 2m P_{\frac{m}{2}} & -H_{\frac{m}{2}} \\ H_{\frac{m}{2}}^{-1} & 0_{\frac{m}{2}} \end{bmatrix} \quad (5)$$

with $P_1 = \frac{1}{2}$ and $H_m^{-1} = \frac{1}{m} H_m^T \text{diag}(r)$ where the vector r is represented by $r := (1, 1, 2, 2, 4, 4, 4, 4, \dots, \underbrace{(\frac{m}{2}, (\frac{m}{2}), \dots, (\frac{m}{2}))^T}_{(\frac{m}{2}) \text{ elements}})$ for

$m > 2$ and the matrix H_m for $\frac{i}{m} \leq t_i < \frac{i+1}{m}$ is defined as

$$H_m = [\Psi_m(t_0), \Psi_m(t_1), \dots, \Psi_m(t_{m-1})]. \quad (6)$$

On the other hand, the product of two vectors $\Psi_m(t)$ is also evaluated as

$$R_m(t) := \Psi_m(t) \Psi_m^T(t) \quad (7)$$

where $R_m(t)$ satisfies the following recursive formula [17]

$$R_m(t) = \frac{1}{2m} \begin{bmatrix} R_{\frac{m}{2}}(t) & H_{\frac{m}{2}} \text{diag}(\Psi_b(t)) \\ (H_{\frac{m}{2}} \text{diag}(\Psi_b(t)))^T & \text{diag}(H_{\frac{m}{2}}^{-1} \Psi_a(t)) \end{bmatrix} \quad (8)$$

with $R_1(t) = \psi_0(t) \psi_0^T(t)$ and

$$\begin{aligned} \Psi_a(t) &:= \left[\psi_0(t), \psi_1(t), \dots, \psi_{\frac{m}{2}-1}(t) \right]^T = \Psi_{\frac{m}{2}}(t) \\ \Psi_b(t) &:= \left[\psi_{\frac{m}{2}}(t), \psi_{\frac{m}{2}+1}(t), \dots, \psi_{m-1}(t) \right]^T. \end{aligned} \quad (9)$$

3. SYSTEM DESCRIPTION

Consider an uncertain n -story building whose base is isolated, as shown in Figure 1. The base is isolated by means of a frictional (passive) damper, Φ , and a control device with semi-active control input $f(t)$. Assume that the system is perturbed by an incoming earthquake. The structure dynamics can be divided into two subsystems, namely, the main structure (S_r) and the base (S_c) [18].

$$\begin{aligned} S_r : \bar{M} \ddot{X}(t) + \bar{C} \dot{X}(t) + \bar{K} X(t) &= [c_1, 0, \dots, 0]^T \dot{y}(t) + [k_1, 0, \dots, 0]^T y(t) \\ S_c : m \ddot{y}(t) + c \dot{y}(t) + k y(t) + f_{br}(t) &= f_{bg}(t) + f(t) - h(t) \\ f_{br}(t) &= c_1 (\dot{y}(t) - \dot{x}_1(t)) + k_1 (y(t) - x_1(t)) \\ f_{bg}(t) &= -c \dot{d}(t) - k d(t) + \Phi(\dot{y}(t), \dot{d}(t)) \\ \Phi(\dot{y}(t), \dot{d}(t)) &= -\text{sgn}(\dot{y}(t) - \dot{d}(t)) [\mu_{max} - \Delta\mu e^{-v|\dot{y}(t) - \dot{d}(t)}] Q \end{aligned} \quad (10a-e)$$

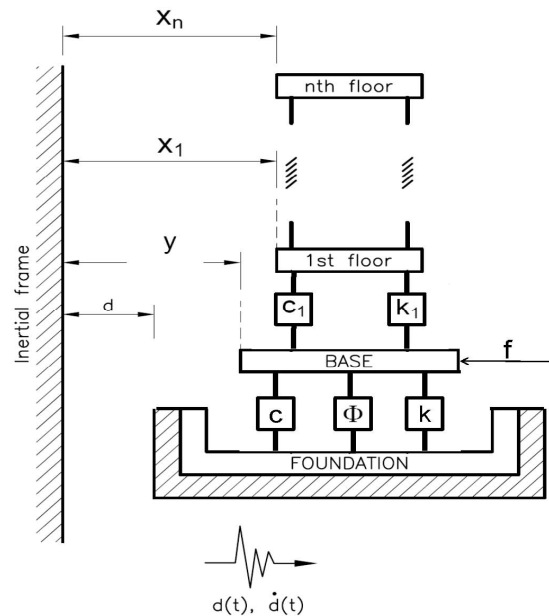

Fig. 1. Schematic of a base Isolated Structure.

where $x = [x_1, x_2, \dots, x_n]^T \in \mathfrak{R}^n$ is the horizontal absolute floor displacement vector, $y \in \mathfrak{R}$ is the horizontal absolute base displacement, $d(t)$ and $\dot{d}(t)$ are the seismic excitation displacement and velocity, $f(t)$ is the active control force applied to the base level. Equation (10c) accounts for the dynamic coupling between the base and the main structure. Equation (10d) describes the forces introduced by the seismic excitation and the base isolation. Equation (10e) describes the dynamics of a frictional base isolator, where μ_{max} is the friction coefficient for high sliding velocity, $\Delta\mu$ is the difference between μ_{max} and the friction coefficient for low sliding velocity, v is a constant and Q is the force normal to the friction surface. Parameters m , c and k are the mass, damping coefficient and stiffness of the base, while matrices \bar{M} , \bar{C} and \bar{K} are those of the main structure as follows:

$$\bar{M} = \text{diag}\{m_1, m_2, \dots, m_n\}$$

$$\bar{C} = \begin{bmatrix} c_1 + c_2 & -c_2 & \dots & 0 & 0 \\ -c_2 & c_2 + c_3 & \dots & 0 & 0 \\ \vdots & \vdots & \ddots & \vdots & \vdots \\ 0 & 0 & \dots & -c_n & c_n \end{bmatrix},$$

$$\bar{K} = \begin{bmatrix} k_1 + k_2 & -k_2 & \dots & 0 & 0 \\ -k_2 & k_2 + k_3 & \dots & 0 & 0 \\ \vdots & \vdots & \ddots & \vdots & \vdots \\ 0 & 0 & \dots & -k_n & k_n \end{bmatrix}. \quad (10f-h)$$

Due to the base isolation, the movement of the main structure (S_r) is very close to the one of a rigid body. Then it is reasonable to assume that the inter-story motion of the main structure will be much smaller than the absolute motion of the base. Consequently, the following simplified equation of motion of the first floor is obtained:

$$m_1 \ddot{x}_1(t) + c_1 \dot{x}_1(t) + kx_1(t) = c_1 \dot{y}(t) + k_1 y(t) \quad (10i)$$

In this work, it is assumed that only state variables of the base and the first floor system are measurable and the unknown seismic excitation $d(t)$ and $\dot{d}(t)$ are bounded and thus the unknown force $f_{bg}(t)$ in (1d) is bounded.

The following propositions about the intrinsic stability of the structure will be used in formulating the control law [18].

Proposition 1. The unforced main structure subsystem, i.e. (1a) with the null coupling term:

$$[c_1, 0, \dots, 0]^T \dot{y} + [k_1, 0, \dots, 0]^T y = 0, \quad t \geq 0 \quad (10j)$$

is globally exponentially stable for any bounded initial conditions.

Proposition 2. If the coordinates (y, \dot{y}) of the base and the coupling term $[c_1, 0, \dots, 0]^T \dot{y} + [k_1, 0, \dots, 0]^T y$ are uniformly bounded, then the main structure subsystem is stable and the coordinates (x, \dot{x}) of the main structure are uniformly bounded for all $t \geq 0$ and any bounded initial conditions.

The main objective of the controller design is to generate an active control force $f(t)$ that reduces the absolute base displacement such that the base isolator can work safely in its elastic region. In order to design an H_∞ controller, we express the dynamics of the base (1b) and the first floor (1i) by the equations of the form

$$M\ddot{x}(t) + C\dot{x}(t) + Kx(t) = B_f f(t) + B_g f_{bg}(t), \quad (11)$$

with $M = \text{diag}\{m_1, m\}$, $C = \begin{bmatrix} c_1 & -c_1 \\ -c_1 & c_1 + c \end{bmatrix}$, $K = \begin{bmatrix} k_1 & -k_1 \\ -k_1 & k_1 + k \end{bmatrix}$,

$B_f = B_g = \begin{bmatrix} 0 \\ 1 \end{bmatrix}$, where $x(t) = [x_1(t), y(t)]^T$ is the state vector.

4. SYSTEM EQUATIONS

The problem of solving the differential equations of the system (11) in terms of the input control and exogenous disturbance is investigated using HFs and an appropriate

algebraic equation is developed. Based on definition of HFs on the time interval $[0, 1]$, we need to rescale the finite time interval $[0, T_f]$ into $[0, 1]$ by considering $t = T_f \sigma$; normalizing the system Eq. (11) with the time scale would be as follows

$$M \ddot{x}(\sigma) + C \dot{x}(\sigma) + K x(\sigma) = B_f f(\sigma) + B_g f_{bg}(\sigma). \quad (12)$$

Now by integrating the system above in an interval $[0, \sigma]$, we obtain

$$M(\dot{x}(\sigma) - \dot{x}(0)) + T_f C(x(\sigma) - x(0)) + T_f^2 K \int_0^\sigma x(\tau) d\tau = T_f^2 B_f \int_0^\sigma f(\tau) d\tau + T_f^2 B_g \int_0^\sigma f_{bg}(\tau) d\tau. \quad (13)$$

To avoid the differentiation of HFs, we take again the integration of (13) in the interval $[0, \sigma]$ as follows:

$$M(x(\sigma) - x(0)) + T_f C \int_0^\sigma x(\tau) d\tau + T_f^2 K \int_0^\sigma \int_0^\xi x(\tau) d\tau d\xi = T_f^2 B_f \int_0^\sigma \int_0^\xi f(\tau) d\tau d\xi + T_f^2 B_g \int_0^\sigma \int_0^\xi f_{bg}(\tau) d\tau d\xi + \int_0^\sigma (M \dot{x}(0) + T_f C x(0)) d\xi. \quad (14)$$

By using the HF expansion (2), we express in the following the solution $x(\sigma)$, input force $f(\sigma)$ and engine disturbance $f_{bg}(\sigma)$ in terms of HFs

$$\begin{aligned} x(\sigma) &= X \Psi_m(\sigma) \\ f(\sigma) &= F \Psi_m(\sigma) \\ f_{bg}(\sigma) &= D_e \Psi_m(\sigma) \end{aligned} \quad (15)$$

where $X: 2 \times m$, $F: 1 \times m$ and $D_e: 1 \times m$ denote the wavelet coefficients of $x(\sigma)$, $f(\sigma)$ and $D_e(\sigma)$, respectively.

The initial conditions of $x(0)$ and $\dot{x}(0)$ are represented by $x(0) = X_0 \Psi_m(\sigma)$ and $\dot{x}(0) = \bar{X}_0 \Psi_m(\sigma)$, where $X_0: 2 \times m$ and $\bar{X}_0: 2 \times m$ are defined as

$$\begin{aligned} X_0 &:= [x(0) \underbrace{0_{2 \times 1} \dots 0_{2 \times 1}}_{(m-1)}], \\ \bar{X}_0 &:= [\dot{x}(0) \underbrace{0_{2 \times 1} \dots 0_{2 \times 1}}_{(m-1)}]. \end{aligned} \quad (16)$$

Therefore, using the HF expansions (15), the relation (14) becomes

$$\begin{aligned} M(X - X_0) \Psi_m(\sigma) + T_f C X \int_0^\sigma \Psi_m(\tau) d\tau + T_f^2 K X \\ \times \int_0^\sigma \int_0^\xi \Psi_m(\tau) d\tau d\xi = T_f^2 B_f F \int_0^\sigma \int_0^\xi \Psi_m(\tau) d\tau d\xi + T_f^2 B_g D_e \\ \times \int_0^\sigma \int_0^\xi \Psi_m(\tau) d\tau d\xi + (M \bar{X}_0 + T_f C X_0) \int_0^\sigma \Psi_m(\xi) d\xi. \end{aligned} \quad (17)$$

Moreover, using the Haar integral operational matrix P_m in (4) and omitting $\Psi_m(\sigma)$ in both sides of Eq. (17), we have

$$\begin{aligned} M(X - X_0) + T_f C X P_m + T_f^2 K X P_m^2 = T_f^2 B_f F P_m^2 \\ + T_f^2 B_g D_e P_m^2 + (M \bar{X}_0 + T_f C X_0) P_m. \end{aligned} \quad (18)$$

For calculating the matrix X , we apply the operator $\text{vec}(\cdot)$ to Eq. (18) and according to the property of the Kronecker product, the following algebraic relation is obtained

$$\begin{aligned} (I_m \otimes M)(\text{vec}(X) - \text{vec}(X_0)) + T_f (P_m^T \otimes C) \text{vec}(X) \\ + T_f^2 (P_m^{2T} \otimes K) \text{vec}(X) = T_f^2 (P_m^{2T} \otimes B_f) \text{vec}(F) \\ + T_f^2 (P_m^{2T} \otimes B_g) \text{vec}(D_e) + T_f (P_m^T \otimes C) \text{vec}(X_0) \\ + (P_m^T \otimes M) \text{vec}(\bar{X}_0). \end{aligned} \quad (19)$$

Solving Eq. (19) for $\text{vec}(X)$ leads to

$$\begin{aligned} \text{vec}(X) = \Delta_1 \text{vec}(F) + \Delta_2 \text{vec}(D_e) + \Delta_3 \text{vec}(X_0) \\ + \Delta_4 \text{vec}(\bar{X}_0) \end{aligned} \quad (20)$$

where the matrices $\Delta_1 : 2m \times m$, $\Delta_2 : 2m \times m$, $\Delta_3 : 2m \times 2m$ and $\Delta_4 : 2m \times 2m$ are defined as

$$\begin{aligned} \Delta_1 &= T_f^2 (T_f (P_m^T \otimes C) + T_f^2 (P_m^{2T} \otimes K) + I_m \otimes M)^{-1} (P_m^{2T} \otimes B_f) \\ \Delta_2 &= T_f^2 (T_f (P_m^T \otimes C) + T_f^2 (P_m^{2T} \otimes K) + I_m \otimes M)^{-1} (P_m^{2T} \otimes B_g) \\ \Delta_3 &= (T_f (P_m^T \otimes C) + T_f^2 (P_m^{2T} \otimes K) + I_m \otimes M)^{-1} (I_m \otimes M + T_f P_m^T \otimes C) \\ \Delta_4 &= (T_f (P_m^T \otimes C) + T_f^2 (P_m^{2T} \otimes K) + I_m \otimes M)^{-1} (P_m^T \otimes M). \end{aligned} \quad (21)$$

Consequently, from (20), (21) and the properties of the Kronecker product, the solution of the system (11) is approximately

$$x(\sigma) = (\Psi_m^T(\sigma) \otimes I_2) \text{vec}(X). \quad (22)$$

5. OPTIMAL CONTROL DESIGN

The control objective is to find the optimal control $f(t)$ with respect to a quadratic cost functional approximately such acts as the active force to compensate the vibration transmitted to the structure. The quadratic cost functional weights the states and their derivatives with respect to time in the cost function as follows:

$$\begin{aligned} J = \frac{1}{2} x^T(T_f) S_1 x(T_f) + \frac{1}{2} \dot{x}^T(T_f) S_2 \dot{x}(T_f) \\ + \frac{1}{2} \int_0^{T_f} (x^T(t) Q_1 x(t) + \dot{x}^T(t) Q_2 \dot{x}(t) + R f(t)^2) dt \end{aligned} \quad (23)$$

where $S_1 : 2 \times 2$, $S_2 : 2 \times 2$, $Q_1 : 2 \times 2$ and $Q_2 : 2 \times 2$ are positive-definite matrices and R is a positive scalar. We can rewrite the cost function (23) as follows:

$$\begin{aligned} J = \frac{1}{2} [x^T(T_f) \quad \dot{x}^T(T_f)] \tilde{S} \begin{bmatrix} x(T_f) \\ \dot{x}(T_f) \end{bmatrix} \\ + \frac{1}{2} \int_0^{T_f} ([x^T(t) \quad \dot{x}^T(t)] \tilde{Q} \begin{bmatrix} x(t) \\ \dot{x}(t) \end{bmatrix} + R f(t)^2) dt \end{aligned} \quad (24)$$

where $\tilde{S} = \text{diag}(S_1, S_2)$ and $\tilde{Q} = \text{diag}(Q_1, Q_2)$. Normalizing (24) with the time scale $t = T_f \sigma$ yields

$$\begin{aligned} J = \frac{1}{2} [x^T(1) \quad T_f^{-1} \dot{x}^T(1)] \tilde{S} \begin{bmatrix} x(1) \\ T_f^{-1} \dot{x}(1) \end{bmatrix} + \frac{T_f}{2} \\ \times \int_0^1 ([x^T(\sigma) \quad T_f^{-1} \dot{x}^T(\sigma)] \tilde{Q} \begin{bmatrix} x(\sigma) \\ T_f^{-1} \dot{x}(\sigma) \end{bmatrix} + R f(\sigma)^2) d\sigma. \end{aligned} \quad (25)$$

From (15) and the relation $\dot{x}(\sigma) = \bar{X} \Psi_m(\sigma)$, where $\bar{X} : 4 \times m$ denotes the wavelet coefficients of $\dot{x}(\sigma)$ after its expansion in terms of HFs, we read

$$\begin{bmatrix} x(\sigma) \\ T_f^{-1} \dot{x}(\sigma) \end{bmatrix} = \begin{bmatrix} X \\ T_f^{-1} \bar{X} \end{bmatrix} \Psi_m(\sigma) := X_{\text{aug}} \Psi_m(\sigma) \quad (26)$$

where $X_{\text{aug}} = \begin{bmatrix} X \\ T_f^{-1} \bar{X} \end{bmatrix}$ and

$$\text{vec}(X_{\text{aug}}) = [\text{vec}^T(X) \quad T_f^{-1} \text{vec}^T(\bar{X})]^T. \quad (27)$$

Remark 1. By substituting $\dot{x}(\sigma) = \bar{X} \Psi_m(\sigma)$ into

$x(\sigma) - x(0) = \int_0^\sigma \dot{x}(t) dt$, we have:

$$X \Psi_m(\sigma) - X_0 \Psi_m(\sigma) = \int_0^\sigma \bar{X} \Psi_m(\tau) d\tau, \quad (28)$$

and using (4), we read $X - X_0 = \bar{X} P_m$. Then, by applying the operator of $\text{vec}(\cdot)$ and according to the properties of Kronecker product, we obtain

$$\text{vec}(X) - \text{vec}(X_0) = (P_m^T \otimes I_n) \text{vec}(\bar{X}). \quad (29)$$

By substituting the definition (26) in (29) and using the properties of the operator $\text{tr}(\cdot)$, the cost function (25) is given by

$$J = \frac{1}{2} (\text{tr}(M_f X_{\text{aug}}^T \tilde{S} X_{\text{aug}})) + \frac{T_f}{2} (\text{tr}(M X_{\text{aug}}^T \tilde{Q} X_{\text{aug}}) + R \text{tr}(M F^T F)) \quad (30)$$

where the matrices $M_m : m \times m$ and $M_{mf} : m \times m$ are defined

as $M_m := \int_0^1 \Psi_m(\sigma) \Psi_m^T(\sigma) d\sigma$ and $M_{mf} := \Psi_m(1) \Psi_m^T(1)$, respectively.

Using the properties of the Kronecker product, we can write (30) as

$$\begin{aligned} J = \frac{1}{2} (\text{vec}^T(X_{\text{aug}} M_{mf}) (I_m \otimes \tilde{S}) \text{vec}(X_{\text{aug}})) \\ + \frac{T_f}{2} (\text{vec}^T(X_{\text{aug}} M_m) (I_m \otimes \tilde{Q}) \text{vec}(X_{\text{aug}}) \\ + R \text{vec}^T(F) M_m \text{vec}(F)) \end{aligned} \quad (31)$$

or

$$J = \frac{1}{2} (\text{vec}^T(X_{\text{aug}}) \Pi_{m1} \text{vec}(X_{\text{aug}}) + \text{vec}^T(F) \Pi_{m2} \text{vec}(F)) \quad (32)$$

where the matrices $\Pi_{m1} : 4m \times 4m$ and $\Pi_{m2} : m \times m$ are defined as $\Pi_{m1} = M_f^T \otimes \tilde{S} + T_f (M^T \otimes \tilde{Q})$ and $\Pi_{m2} = R T_f M_m$, respectively. It is clear that the cost function of $J(\cdot)$ is a function of $\frac{i}{m} \leq \sigma_i < \frac{i+1}{m}$, then for finding the optimal control law, which minimizes the cost functional $J(\cdot)$, the following necessary condition should be satisfied

$$\frac{\partial J}{\partial \text{vec}(F)} = 0. \quad (33)$$

By considering $\text{vec}(X_{\text{aug}})$, which is a function of $\text{vec}(F)$, and using the properties of derivatives of inner product of Kronecker product, we find

$$\begin{aligned} \frac{\partial J}{\partial \text{vec}(F)} = [\Delta_1^T \quad T_f^{-1} \Delta_1^T (P_m^{-1} \otimes I_4)] \Pi_{m1} \text{vec}(X_{\text{aug}}) \\ + \Pi_{m2} \text{vec}(F). \end{aligned} \quad (34)$$

Then the wavelet coefficients of the optimal control law will be in vector form as

$$\text{vec}(F) = -\Pi_{m2}^{-1} [\Delta_1^T \quad T_f^{-1} \Delta_1^T (P_m^{-1} \otimes I_4)] \Pi_{m1} \text{vec}(X_{\text{aug}}). \quad (35)$$

Consequently, from (20), (27), (29) and (35) the optimal vectors of $\text{vec}(X)$ and $\text{vec}(F)$ are found, respectively, in the following forms

$$\begin{aligned} \text{vec}(X) = & (I_{4m} + \Delta_1(\Pi_{m2}^{-1}[\Delta_1^T \quad T_f^{-1}\Delta_1^T(P_m^{-1} \otimes I_4)] \Pi_{m1} \\ & \times \left[\begin{array}{c} I_{4m} \\ T_f^{-1}(P_m^T \otimes I_4)^{-1} \end{array} \right]^{-1}(\Delta_2 \text{vec}(D_e) + (\Delta_1 \Pi_{m2}^{-1} \\ & \times [\Delta_1^T \quad T_f^{-1}\Delta_1^T(P_m^{-1} \otimes I_4)] \Pi_{m1} \left[\begin{array}{c} 0_{4m} \\ T_f^{-1}(P_m^T \otimes I_4)^{-1} \end{array} \right] + \Delta_3) \\ & \times \text{vec}(X_0) + \Delta_4 \text{vec}(\bar{X}_0)), \end{aligned} \quad (36)$$

and

$$\begin{aligned} \text{vec}(F) = & -\Pi_{m2}^{-1}[\Delta_1^T \quad T_f^{-1}\Delta_1^T(P_m^{-1} \otimes I_4)] \Pi_{m1} \\ & \times \left\{ \left[\begin{array}{c} I_{4m} \\ T_f^{-1}(P_m^T \otimes I_4)^{-1} \end{array} \right] (I_{4m} + \Delta_1 \Pi_{m2}^{-1} \right. \\ & \times [\Delta_1^T \quad T_f^{-1}\Delta_1^T(P_m^{-1} \otimes I_4)] \Pi_{m1} \left. \left[\begin{array}{c} I_{4m} \\ T_f^{-1}(P_m^T \otimes I_4)^{-1} \end{array} \right]^{-1} \right\}^{-1} \\ & \times (\Delta_2 \text{vec}(D_e) + (\Delta_1 \Pi_{m2}^{-1}[\Delta_1^T \quad T_f^{-1}\Delta_1^T(P_m^{-1} \otimes I_4)] \Pi_{m1} \\ & \times \left[\begin{array}{c} 0_{4m} \\ T_f^{-1}(P_m^T \otimes I_4)^{-1} \end{array} \right] + \Delta_3) \text{vec}(X_0) + \Delta_4 \text{vec}(\bar{X}_0)) \\ & - \left[\begin{array}{c} 0_{4m} \\ T_f^{-1}(P_m^T \otimes I_4)^{-1} \end{array} \right] \text{vec}(X_0) \}. \end{aligned} \quad (37)$$

Finally, the Haar function-based optimal trajectories and optimal control are obtained approximately from Eq. (22) and $f(t) = \Psi_m^T(t) \text{vec}(F)$.

Remark 2. Since the vector $\Psi_m(\sigma)$ is constant within each of the m time intervals, the approximated optimal trajectories (38) and optimal control (39) can be expressed as

$$\begin{aligned} x(t) = & \sum_{i=1}^m G_i \text{vec}(X_0) + \sum_{i=1}^m \bar{G}_i \text{vec}(\bar{X}_0) + \sum_{i=1}^m \tilde{G}_i \text{vec}(D_e), \\ f(t) = & -\left(\sum_{i=1}^m F_i \text{vec}(X_0) + \sum_{i=1}^m \bar{F}_i \text{vec}(\bar{X}_0) + \sum_{i=1}^m \tilde{F}_i \text{vec}(D_e) \right) \end{aligned}$$

with constant matrices $G_i: 4 \times 4m$, $\bar{G}_i: 4 \times 4m$, $\tilde{G}_i: 4 \times m$, $F_i: 1 \times 4m$, $\bar{F}_i: 1 \times 4m$ and $\tilde{F}_i: 1 \times m$ within each of time intervals $\frac{i}{m} \leq \sigma_i < \frac{i+1}{m}$ for $i=0,1,\dots,(m-1)$.

6. NUMERICAL RESULTS

The controller is implemented with the following numerical values: the mass and stiffness of the base are $m = 6 \times 10^5$ kg, $k = 1.184 \times 10^7$ N/m, and the base damping ratio is 0.1, respectively; the main structure stiffness varies linearly from the first floor ($k_1 = 9 \times 10^8$ N/m) to the top floor ($k_{10} = 4.5 \times 10^8$ N/m); and the damping ratio is 0.05. The frictional damper has the following values: $Q = \sum_{i=1}^{10} m_i$, $\mu_{\max} = 0.185$, $\Delta\mu = 0.09$, and $v = 2.0$. Moreover, the matrices S_1 , S_2 , Q_1 and Q_2 and scalar R in the cost function (23) are chosen as $S_1 = S_2 = 0_4$, $Q_1 = 10 Q_2 = I_2$ and $R = 1$. The simulation is run by exciting the structure with the records of the El Centro earthquake, as shown in Figure 2.

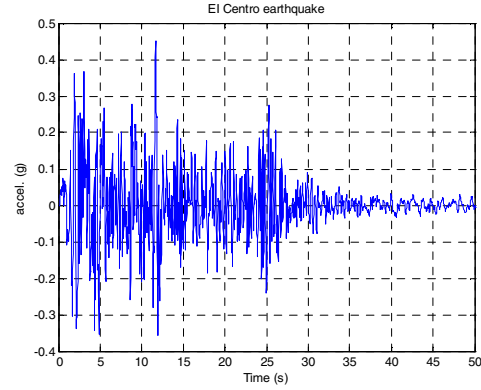

Fig. 2. The earthquake record.

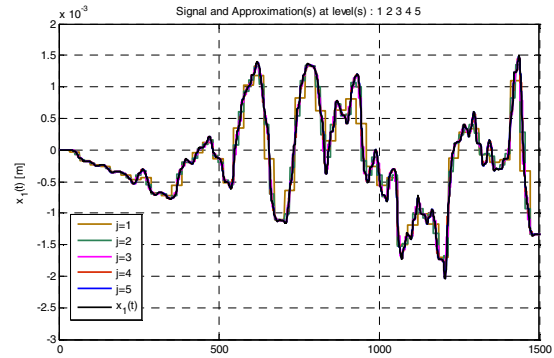

Fig. 3. Comparison of displacement of the first story found by HF's at resolution levels $j=1,2,\dots,5$ and by analytic solution.

Figures 3 and 4 show comparison of the displacement of the first story $x_1(\sigma)$ and optimal control $f(\sigma)$ found by HF's at different resolution levels and the analytic solution found by solving the differential Riccati equation, respectively. Figures show that the HF's can construct the vibration signals as well. Moreover, decomposition of the displacement $x_1(t)$ at level $j=5$ in terms of approximation coefficient (a_5) and detail coefficients (d_1, d_2, \dots, d_5) are plotted in Figure 5. It is clear that by increasing the resolution level j the accuracy of the approximation can be improved as well.

7. CONCLUSION

This paper presented a numerical method to find an optimal vibration control based on Haar functions (HF's) for a base-isolated building. Utilizing properties of HF's, a computational method to find control gains was developed. It was shown that the optimal state trajectories and optimal vibration control are calculated approximately by solving only algebraic equations instead of solving the Riccati differential equation. The simulation results were included to illustrate the validity and applicability of the proposed technique.

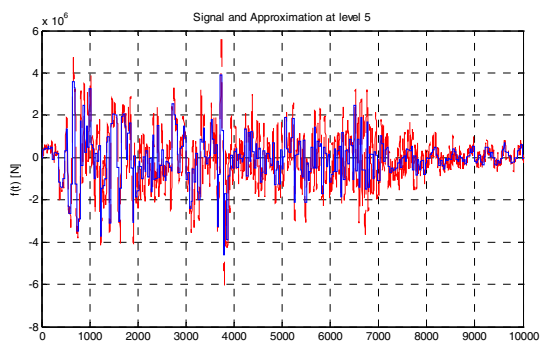

Fig. 4. Comparison of the control force found by HFts at resolution level $j=5$ (solid line) and by analytic solution (dashed line).

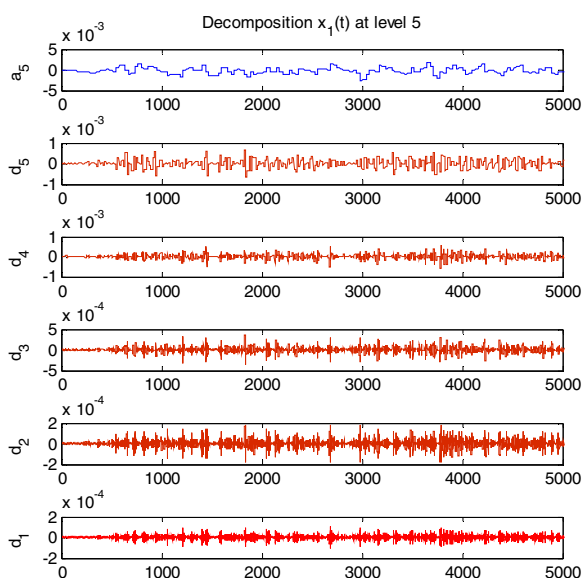

Fig. 5. Decomposition of the displacement $x_1(t)$ at level $j=5$ in terms of approximation coefficient (a_5) and detail coefficients (d_1, d_2, \dots, d_5).

ACKNOWLEDGEMENTS

This work has been (partially) funded by Norwegian Centre for Offshore Wind Energy (NORCOWE) under grant 193821/S60 from Research Council of Norway (RCN). NORCOWE is a consortium with partners from industry and science, hosted by Christian Michelsen Research.

REFERENCES

[1] M. Zapateiro, N. Luo, H.R. Karimi, J. Vehí, ‘Vibration control of a class of semiactive suspension system using neural network and backstepping techniques’, *Mechanical Systems and Signal Proces.*, vol. 23, pp. 1946–1953, 2009.
[2] M. Zapateiro, H.R. Karimi, N. Luo, Phillips B.M., and Spencer, Jr. B.F., ‘Semiactive backstepping control for vibration reduction in a structure with Magnetorheological damper subject to seismic motions’ *J. Intelligent Material Systems and Struc.*, vol. 20, no. 17, pp. 2037-2053, 2009.
[3] H.R. Karimi, M. Zapateiro, N. Luo, ‘Vibration control of base-isolated structures using mixed H_2/H_∞ output-feedback control’ *J. of Systems and Control Engineering*,

Proceedings of the Institution of Mechanical Engineers, vol. 223, no. 6, pp. 809-820, 2009.
[4] M. Zapateiro, H.R. Karimi, N. Luo, and B.F. Spencer, Jr., ‘Frequency domain control based on Quantitative Feedback Theory for vibration suppression in structures equipped with Magnetorheological dampers’ *Smart Materials and Structures*, vol. 18, 095041 (13pp), 2009.
[5] M. Zapateiro, H.R. Karimi, N. Luo, and B.F. Spencer, Jr., ‘Real-time hybrid testing of semiactive control strategies for vibration reduction in a structure with MR damper’ *J. of Structural Control and Health Monitoring*, doi: 10.1002/stc.321, published online: Feb 10 2009.
[6] A. Patra and G. P. Rao, ‘General Hybrid Orthogonal Functions and their Applications in Systems and Control’ Springer-Verlag, London, 1996.
[7] C. F. Chen and C. H. Hsiao, ‘Haar Wavelet Method for Solving Lumped and Distributed-Parameter Systems’ *IEE Proc. Control Theory Appl.*, vol. 144, no. 1, pp. 87-94, 1997.
[8] H. R. Karimi, B. Lohmann, P. J. Maralani and B. Moshiri ‘A Computational Method for Solving Optimal Control and Parameter Estimation of Linear Systems Using Haar Wavelets’ *Int. J. Computer Mathematics*, vol. 81, no. 9, pp. 1121-1132, 2004.
[9] G. P. Rao, ‘Piecewise Constant Orthogonal Functions and Their Application to Systems and Control’ Springer-Verlag, Berlin, Heidelberg, 1983.
[10] C. F. Chen and C. H. Hsiao, ‘A State-Space Approach to Walsh Series Solution of Linear Systems’ *Int. J. System Sci.*, vol. 6, no. 9, pp. 833-858, 1965.
[11] R. Y. Chang and M. L. Wang, ‘Legendre Polynomials Approximation to Dynamical Linear State-Space Equations with Initial and Boundary Value Conditions’ *Int. J. Control*, vol. 40, pp. 215-232, 1984.
[12] I.R. Horng, and J.H. Chou, ‘Analysis, Parameter Estimation and Optimal Control of Time-Delay Systems via Chebyshev series’ *Int. J. Control*, vol. 41, pp. 1221-1234, 1985.
[13] H. R. Karimi, ‘A Computational Method to Optimal Control Problem of Time-Varying State-Delayed Systems by Haar Wavelets’ *Int. J. Computer Mathematics*, vol. 83, no. 2, pp. 235-246, 2006.
[14] H. R. Karimi, P. J. Maralani, B. Moshiri, and B. Lohmann, ‘Numerically Efficient Approximations to the Optimal Control of Linear Singularly Perturbed Systems Based on Haar Wavelets’ *Int. J. Computer Mathematics*, vol. 82, no. 4, pp. 495-507, April 2005.
[15] H. R. Karimi, B. Lohmann, B. Moshiri and P. J. Maralani, ‘Wavelet-Based Identification and Control Design for a Class of Non-linear Systems’ *Int. J. Wavelets, Multiresolution and Image Processing*, vol. 4, no. 1, pp. 213-226, 2006.
[16] M. Ohkita and Y. Kobayashi ‘An Application of Rationalized Haar Functions to Solution of Linear Differential Equations’ *IEEE Trans. Circuit and Systems*, vol. 9, pp. 853-862, 1986.
[17] C. H. Hsiao and W. J. Wang, ‘State Analysis and Parameter Estimation of Bilinear Systems via Haar Wavelets’ *IEEE Trans. Circuits and Systems I: Fundamental Theory and Applications*, vol. 47, no. 2, pp. 246-250, 2000.
[18] Luo N., Rodellar J., De la Sen M., Vehi J., ‘Output feedback sliding mode control of base isolated structures’ *J. the Franklin Institute*, vol. 337, pp. 555–577, 2000.